

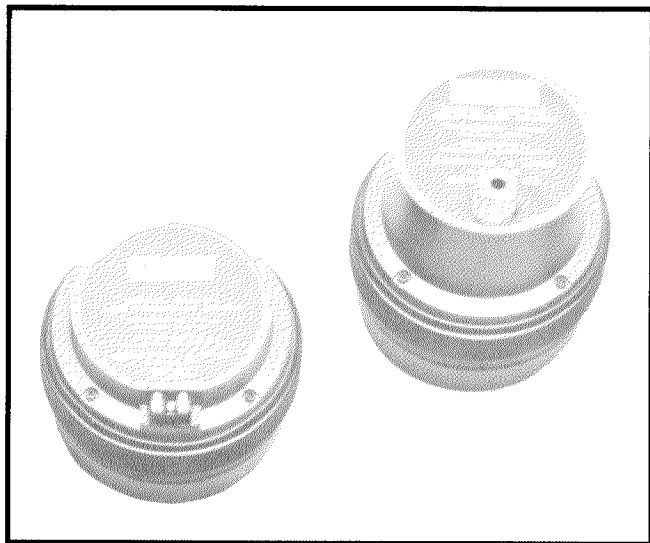

299 Series High Frequency Compression Drivers



KEY FEATURES

- ★ Wide Bandwidth
- ★ High Acoustic Output
- ★ Smooth and Transparent

The Altec Lansing **299 Series** high frequency compression drivers are designed for use in high level sound reinforcement systems where a very wide bandwidth together with large acoustic output is required. Used with Altec Lansing Mantaray® high frequency horns, the energy produced by these drivers can be directed to cover an audience accurately and completely. Their wide range response, when complimented by Altec Lansing low frequency loudspeakers and enclosures, will provide smooth reproduction of speech and music for all types of auditoriums, churches, stadiums, and arenas.

Combining modern materials and adhesives with a proven dome and compliance geometry results in a driver with a new Pascalite™ diaphragm construction having equivalent power handling and output capabilities as drivers with 2.0 inch (4.9 cm) exit throat diameters, while maintaining superior high frequency power bandwidth.

DESCRIPTION

The 299 magnetic structure utilizes a 6.7 lbs (3.0 kgs) ferrite magnet with a 2.05 Tesla gap flux density and retains the internal acoustic cavities and sonic qualities of earlier model 200 series drivers. A Tangerine® radial phasing plug guarantees a smooth upper range response.

As with every Altec Lansing compression driver, the diaphragm/voice coil assembly can be replaced in the field without the use of special tools. Adjustable dowel pins allow each voice coil to be centered in the magnetic gap. The **299-8A** provides a minimum impedance of 8 ohms. The **299-8AT** is for outdoor applications and includes an extended back cover and mounting plate for installation of a line transformer. The **299-16A** provides a minimum impedance of 16 ohms.

The outstanding performance characteristics of the **299 Series** high frequency compression drivers make them the high frequency component of choice for all large sound systems.

KEY SPECIFICATIONS

Pressure Sensitivity:

145 dB SPL (1W, 500 Hz to 3 kHz, see Note 1).
112 dB SPL on MR94B (1W, 500 Hz to 3 kHz, see Note 2).

Frequency Response:

500 Hz to 15 kHz (see Fig. 1, Note 3; Fig. 3, 4 Note 4).

Power Handling:

500 Hz to 5 kHz: 50 W AES method (see Note 6).
100 W continuous program (see Note 9).
200 W peak power (see Note 10).
1 kHz to 10 kHz: 75 W AES method (see Note 6).
150 W continuous program (see Note 9).
300 W peak power (see Note 10).

Maximum Long-Term Output:

126 dB SPL on MR11594A (50 W/1m, see Note 7).
128 dB SPL on MR94B (50 W/1m, see Note 7).

Impedance:

299-8A/8AT: 8 ohms minimum.
299-16A: 16 ohms minimum (see Fig. 1,3,4 Note 8).

SPECIFICATIONS (continued)

Voice Coil DCR:		Dimensions:	
299-8A/8AT:	5.5 ohms.	299-8A/16A:	7.7 inches (19.6 cm) diameter, 5.8 inches (14.8 cm) depth, less mounting studs.
299-16A:	11.3 ohms.		
Input Connection:		299-8AT:	7.7 inches (19.6 cm) diameter, 8.5 inches (21.6 cm) depth, less mounting studs.
299-8A/16A:	Screw terminals with .250 inch lugs for push-on connectors, positive terminal marked with a plus sign.		
299-8AT:	Waterproof gland nut on back. Connections made with wire nuts.	Replacement Diaphragms:	Model 25884, 8 ohms. Model 25885, 16 ohms.
Diaphragm Construction:	Hydropneumatically formed all-metal dome and tangential compliance driven by a 2.8 inch (7.2 cm) diameter voice coil of edge wound aluminum ribbon.	Weight:	
		Net:	30.5 lbs. (13.8 kgs).
		Shipping:	32.0 lbs. (14.5 kgs).
Displacement Limit:	±0.035 inch (0.89 mm), mechanical limit when diaphragm dome strikes phasing plug.	Finish:	Gray polyurethane paint.
Thermal Data After Power Handling Test:	Voice coil temperature, 95°C. (50 watts), measured by resistance change. Magnetic structure tem- perature, 38°C. (50 watts), mea- sured with electronic thermometer.	Mounting Date:	Three 3/8-24 studs on a 3.25 inch diameter bolt circle, or four 3/8-24 studs on a 4.75 inch diameter bolt circle.
		Accessories:	MR Series Mantaray [®] horns. MRII Series Mantaray [®] horns. 15480 Line Transformer (299-8AT).

Altec Lansing continually strives to improve products and performance. Therefore, specifications are subject to change without notice.

NOTES ON MEASUREMENT CONDITIONS

1. Pink noise signal, one watt calculated using E^2/Z_{min} , 1.4 inch (3.5 cm) diameter plane wave tube measurement referred to a one inch (2.5 cm) diameter plane wave tube.
2. On-axis, pink noise signal, one watt calculated using E^2/Z_{min} , 3.16 meter measurement distance referred to one meter.
3. One watt calculated using E^2/Z_{min} , 1.4 inch (3.5 cm) diameter plane wave tube measurement referred to a one inch (2.5 cm) diameter plane wave tube.
4. On-axis, one watt calculated using E^2/Z_{min} , 3.16 meter measurement distance referred to one meter.
5. Distortion components invalid above 10 kHz. The percentage distortion of a harmonic at any given frequency may be found by graphically taking the difference between the fundamental and harmonic, adding 12 dB, and applying the formula: percentage distortion = $100 \times 10^{(-dB \text{ change}/20)}$
6. Test made on a horn with loading to 500 Hz, pink noise signal with 6 dB crest factor, power calculated using E^2/Z_{min} , 12 dB/octave filter slopes, for two hours.
7. This measurement made under the same conditions as Pressure Sensitivity, but at rated power, and takes into account any power compression effects due to non-linearities in the device.
8. Minimum impedance occurs in frequency between 4 kHz and 5 kHz. Maximum production variation in minimum impedance is ± 15%.
9. Continuous program is defined as 3 dB greater than the AES rating using a pink noise signal with 6 dB crest factor.
10. Peak power is defined as 6 dB greater than the AES rating using a pink noise signal with 6 dB crest factor.

299-8A/16A DIMENSIONS

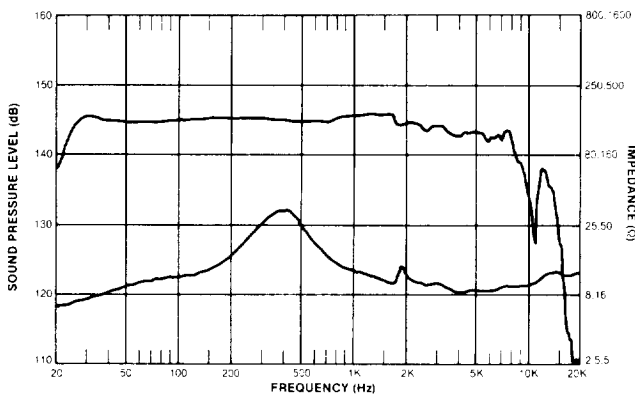
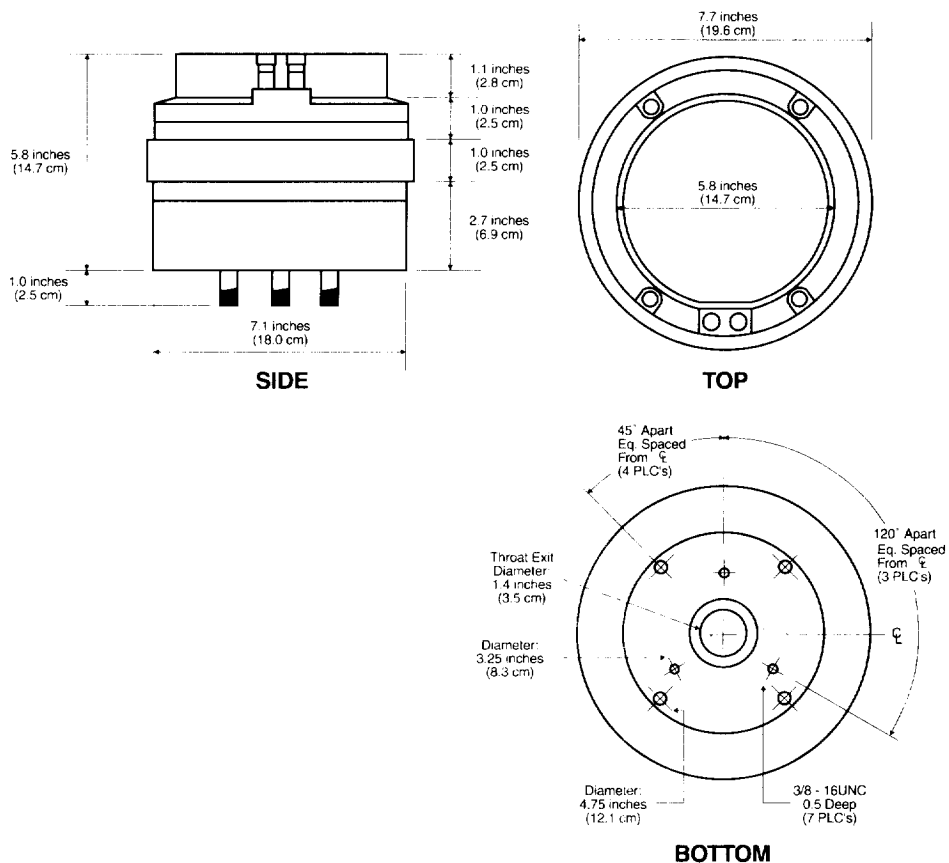

Figure 1. Plane Wave Tube Frequency Response and Magnitude of Impedance (See Notes 3, 8)

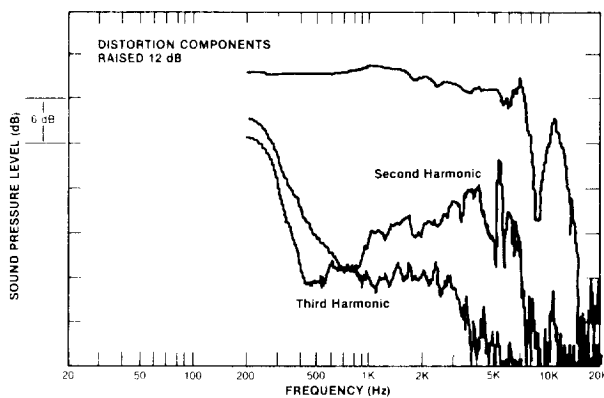

Figure 2. Plane Wave Tube Harmonic Distortion at 0.1 Rated Power (5 watts, See Note 5)

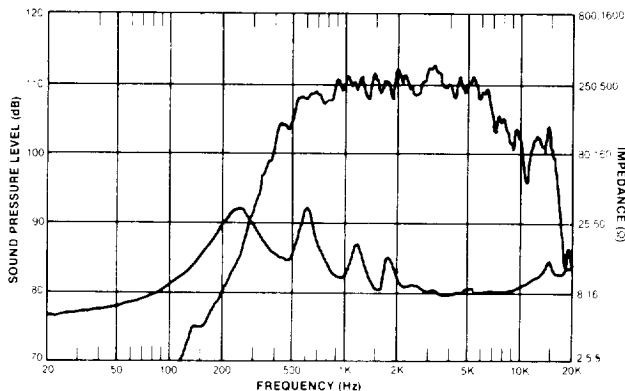

Figure 3. Frequency Response and Magnitude of Impedance on MR94B horn (See Note 4)

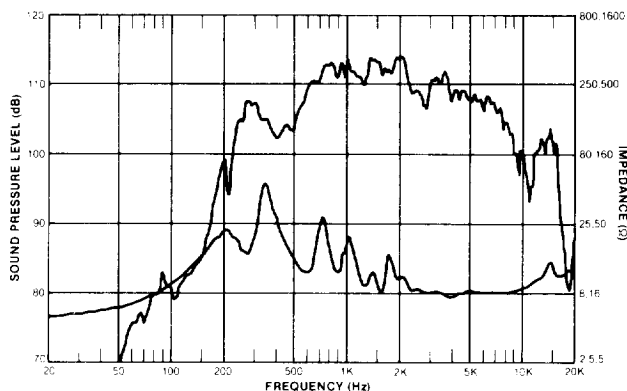
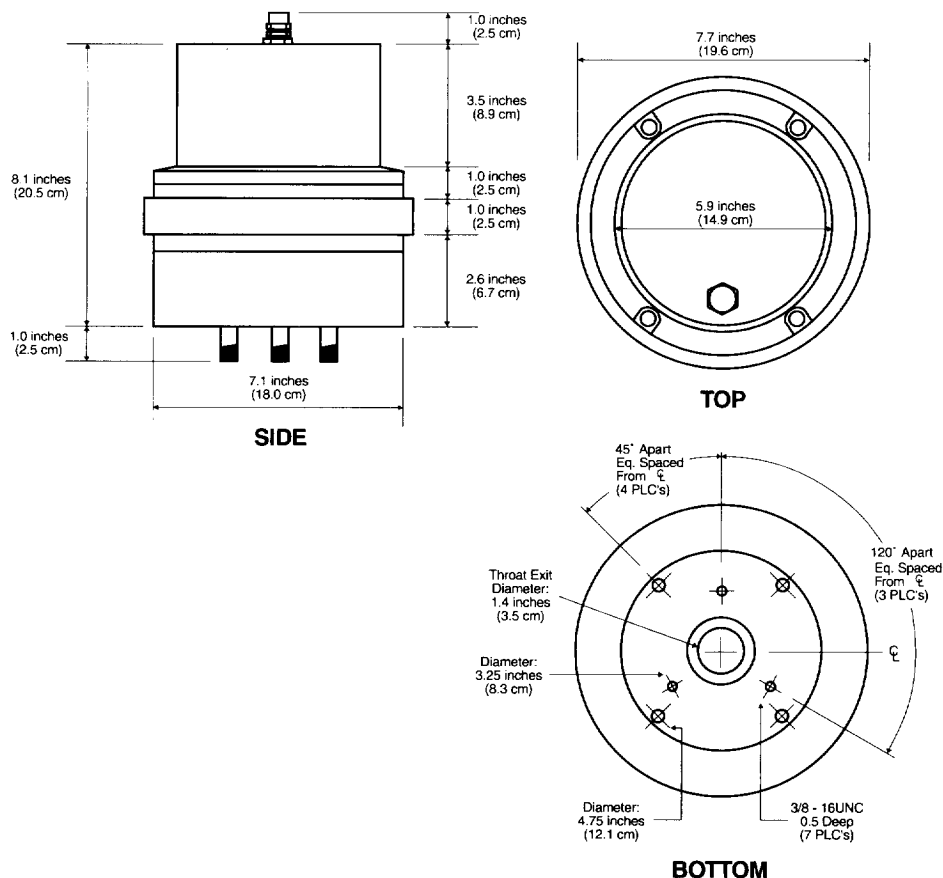

Figure 4. Frequency Response and Magnitude of Impedance on MR11594A horn (See Note 4)

299-8AT DIMENSIONS



ARCHITECT'S AND ENGINEER'S SPECIFICATIONS

The compression driver loudspeaker shall meet the following criteria: Power handling: 50 watts continuous pink noise, band limited from 500 Hz to 5 kHz, when mounted on an Altec Lansing 500 Hz horn. Frequency response, uniform from 500 Hz to 15 kHz. Pressure sensitivity shall be 110 ± 1 dB SPL when measured at one meter on-axis from the mouth of an Altec Lansing Mantaray® MR11594A horn with one watt input of pink noise, band limited from 500 Hz to 3 kHz. Minimum impedance: 8 ohms (299-8A, 299-8AT); 16 ohms (299-16A). The voice coil shall be 2.8 inches (7.2 cm) in diameter, of edge wound aluminum ribbon, and shall operate in a magnetic gap having a flux density of 2.05 T derived from a 6.7 pound (3.0 kgs) Ferrite V magnet. The dome and tangential

compliance shall be of Pascalite™ all-metal construction. Tangerines phasing plug with thirteen radial acoustic slots shall provide the proper phase relationship between sound emanating from the center and edges of the dome. The entire diaphragm and voice coil assembly shall be field replaceable without requiring special tools; adjustable dowel pins shall allow each voice coil to be precisely centered in the magnetic gap. The driver shall be 7.7 inches (19.6 cm) in diameter by 5.8 inches (14.7 cm) deep for the 299-8A and 299-16A or 8.5 inches (21.6 cm) deep for the 299-8AT. The unit shall weigh 30.5 pounds (13.8 kgs).

The compression driver loudspeaker shall be the Altec Lansing Model 299-8A, 299-8AT or the Altec Lansing Model 299-16A.



a MARK IV company

P.O. BOX 26105 • OKLAHOMA CITY, OK 73126-0105 • U.S.A.

Phone: 405/324-5311 or FAX: 405/324-8981

© 1994 ALTEC LANSING CORPORATION