

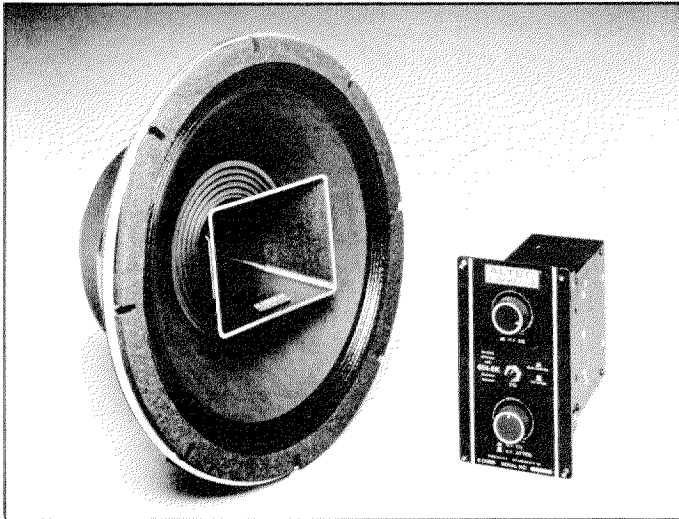

604-8K 16" Duplex® Loudspeaker



PRIMARY SPECIFICATIONS

System Type: Two-way, full range, Duplex® loudspeaker system employing compression driver and horn.

Pressure sensitivity: 98.5 dB SPL (1W,500Hz - 3kHz, re: 20μPa, see note 1).

Frequency Response: 60 Hz - 20 kHz (see Figure 1, Note 2)

Power Handling: 75 watts, 60 Hz - 20 kHz, AES method (see note 3).

Maximum Long Term Output: 116.8 dB SPL (75 watts input, 1m, re:20μPa, see note 4).

Impedance: 8.5 ohms minimum.
8.0 ohms nominal.

Components: 16 inch, high efficiency, low frequency driver with a coaxially mounted, 1.0-inch, compression driver and Mantaray® horn.

KEY FEATURES

- ★ Offers Controlled Dispersion, High Efficiency
- ★ Includes Dual Section Crossover , Centered at 1500 Hz, with Dual Equalization Networks
- ★ Dual Magnet Construction

DESCRIPTION

The Altec Lansing **604-8K** Duplex® loudspeaker system consists of a two-way coaxial loudspeaker and a dividing network with dual equalization (mid and high frequency). The loudspeaker features a 16-inch low-frequency cone and a coaxially mounted 902 high-frequency compression driver. The dual magnet construction allows each speaker to be structurally, magnetically, electrically and mechanically independent of the other. The **604-8K** utilizes a dual section crossover network, centered at 1500Hz and providing 12dB of attenuation for the low-frequencies and 18dB for the high-frequencies.

The low-frequency cone driver features a 3.0-inch diameter edge-wound copper ribbon voice-coil and a 5.6lb ferrite magnet that produces a gap flux density of 1.3T. The high-frequency compression driver features a 1.75-inch diameter edge-wound aluminum ribbon voice-coil and a 2.5lb ferrite magnet that produces a gap flux density of 1.6T. The high-

frequency driver feeds through the low-frequency magnetic structure into a 60° by 40° Mantaray® constant directivity horn that provides tight control of frequencies above 1500Hz.

The **5191-X** enclosure is available as an accessory, and provides an internal volume of 6 ft³. The enclosure is a vented (or reflex) design and is tuned to provide optimum performance when used with the **604-8K**. The **5191-X** (including grille assembly) is constructed from heavy-gauge, rugged cold rolled steel, reinforced by formed ribs, under-coated to prevent panel resonance, and finished with rust-inhibiting paint. In addition the interior is lined with glass wool blankets.

The **604-8K** provides high acoustical power output capability while maintaining smooth response, wide bandwidth and constant directivity control of the critical mid and high-frequencies.

Crossover Network:	Two-way at 1500 Hz with a 12 dB per octave slope for the low-frequencies and 18dB for high-frequencies.
Input Terminals:	250-inch spade type terminals.
Accessories:	5191-X Enclosure and Grille assembly
Replacement Diaphragm Assembly:	34647
LF Cone Kit:	R-604-8K
Dimensions,	
Diameter:	16.0in (40.64cm)
Depth:	18.2in (22.38cm)
Net Weight:	34.0 lbs (15.4 kg), includes network.
Shipping Weight:	42.0 lbs (19.0 kg), includes network.
Finish:	Dark grey enamel.

SPECIFICATION - 5191-X ENCLOSURE

Construction Material:	Reinforced, 18 guage cold rolled steel.
Coating:	Undercoated for panel resonance damping.
Glass Wool Lining:	1.5in (3.7cm) glass wool blankets.
Volume:	6 ft ³ (169.8 litres)
Dimensions:	29.5in (74.9cm)L, 23.0in (58.4cm)W, 15.0in (38.1cm)D.
Weight:	60 lbs (27.2 kg)
Grille:	20.0in (50.8cm) square, white finish.

NOTES ON MEASUREMENT CONDITIONS

- Pink noise signal, one Watt calculated using E^2/Z_{min} , 3.16 measurement distance referred to one meter.
- On-axis, one Watt calculated using E^2/Z_{min} , 3.16 meter measurement distance referred to one meter, low frequencies corrected for anechoic chamber error.
- This system rating patterned after the A.E.S method for individual driver, where the test signal is pink noise with a 6dB crest factor over the bandwidth of the system, with power calculated using the E^2/Z_{min} , for two hours.
- This measurement made under the same conditions as Pressure Sensitivity, but at rated power, and takes into account any power compression effects due to non-linearities in the system.
- Distortion components invalid above 10kHz. The distortion at any given frequency may be found by graphically taking the difference between the fundamental and harmonic, and adding the number of Decibels which the harmonic has been raised on the graph and apply the formula:
percent distortion = $100 \times 10^{-(\text{difference in dB}/20)}$

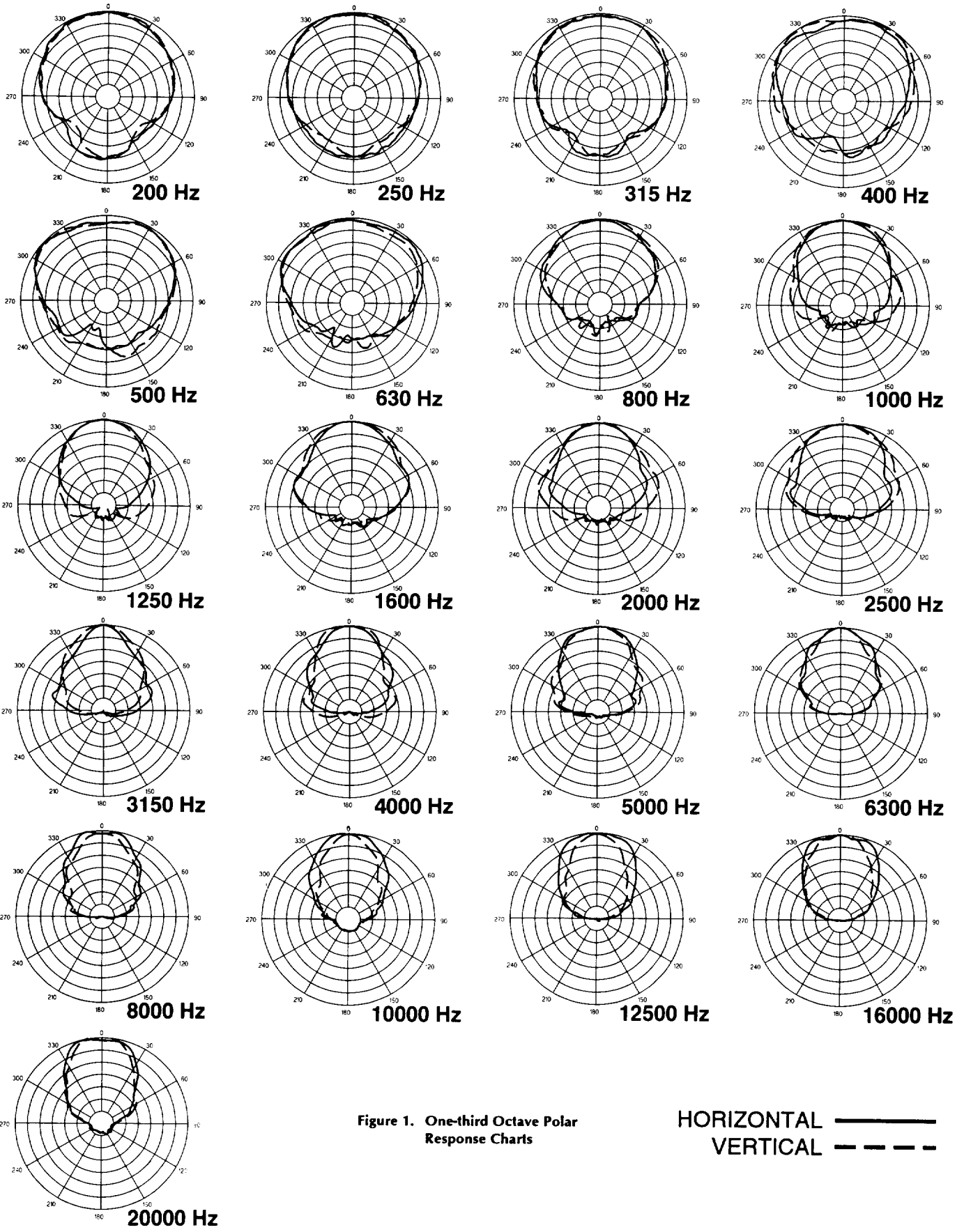

Figure 1. One-third Octave Polar Response Charts

HORIZONTAL ———
VERTICAL - - -

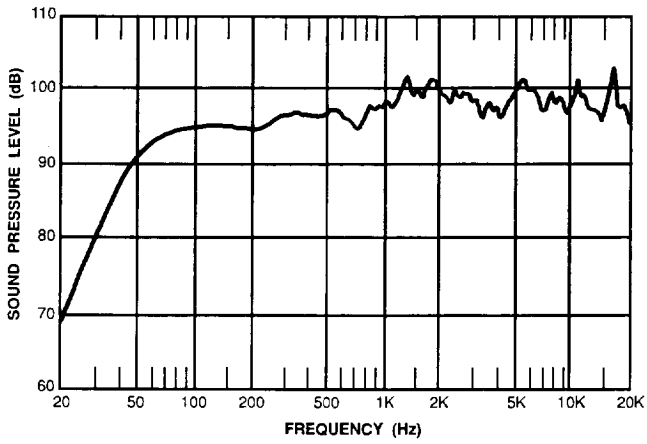

Figure 2. Amplitude Response

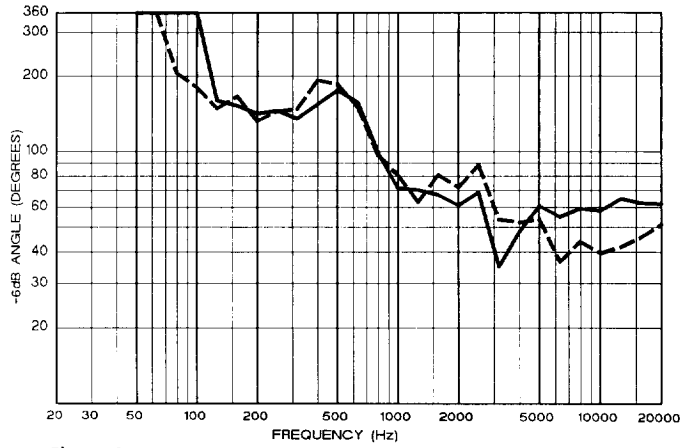

Figure 3. Beamwidth vs. Frequency

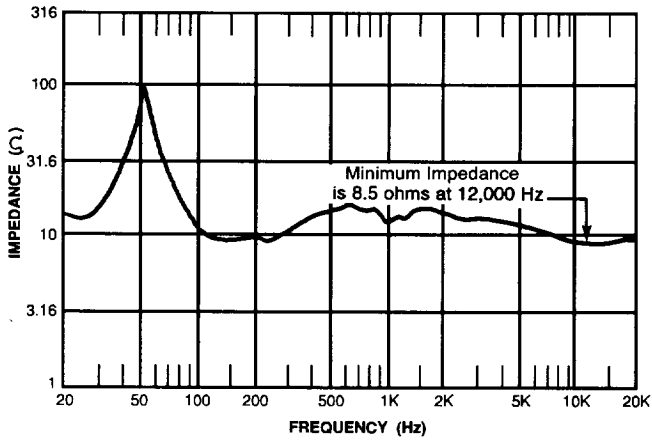

Figure 4. Impedance Response

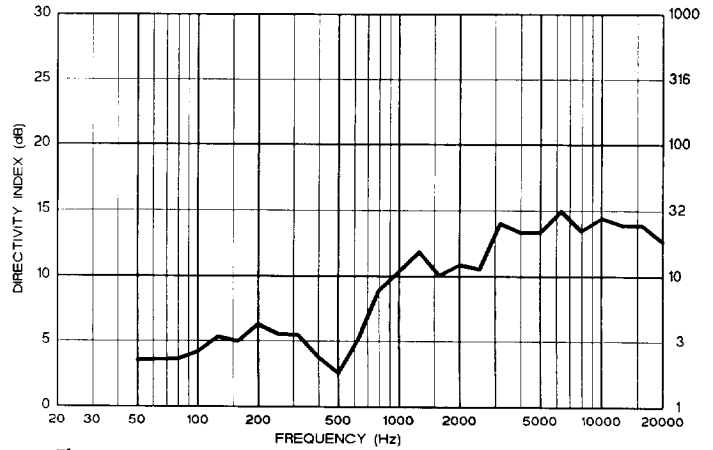

Figure 5. Directivity and Q

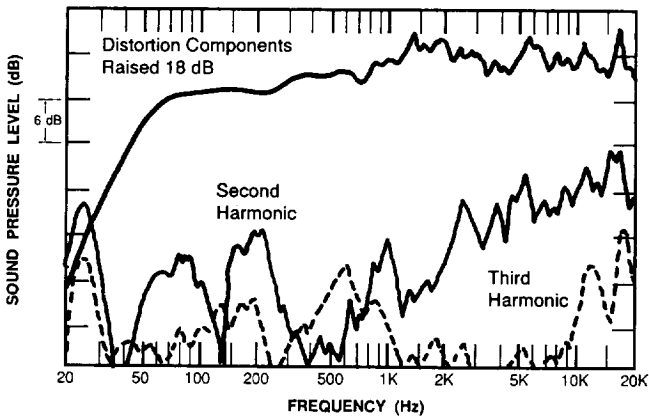

Figure 6. Distortion Response

604-8K - THEILE-SMALL PARAMETERS

Free Air Resonance, f_s :	24 Hz
Equivalent Volume Compliance, V_{as} :	18.0 ft. ³
Total Q, Q_{ts} :	0.9287
Electrical Q, Q_{es} :	0.299
Mechanical Q, Q_{ms} :	7.07
Volume Displacement, V_D :	19.2 in. ³
Reference Efficiency:	2.13%

NOTE: MEASUREMENTS WERE MADE IN A 6 FT³ VENTED ENCLOSURE

NETWORK INSTALLATION

Networks are installed with T-nuts and bolt to a surface having a cutout of the dimensions shown in Figure 7. Use the template given at the end of these instructions to facilitate installation.

To make the cutout, first fix the template to the surface where the network is to be mounted. Use a 7/32" (0.218) drill to bore four holes to accept shafts of 8-32 T-nuts. A recommended method to make the cutout is to cut slightly undersize and use a wood rasp or file to finish the edges to exact size. Remove all

debris from the holes, from the cut edges, and from within the enclosure. Insert four T-nuts in mounting holes, from the inner side of the enclosure. Gently hammer each T-nut in place, until the faces of the T-nuts are flush with the surface. Insert the network in the cutout and secure with four 8-32 bolts. Prior to inserting the network, it may be desirable to connect system wiring to the terminals; refer to wiring diagram of Figure 10.

LOUDSPEAKER INSTALLATION

The loudspeaker is installed with T-nuts and bolts to a baffle having a cutout and mounting bolt pattern as listed in the table of specifications.

The loudspeaker may be front or rear mounted. Front mounting is recommended for best performance. A baffle of 3/4" particle board or plywood which is free of voids is recommended. Secure the loudspeaker to the baffle with eight bolts, with the loudspeaker oriented so that the Mantaray® designation reads horizontally. If only four mounting bolts are used, they should secure the loudspeaker at the mounting holes nearest the frame members.

To make the loudspeaker cutout, locate and scribe circles for the loudspeaker hole and the mounting bolts. See table of specifications for dimensions. Cut out the smaller circle (loudspeaker hole). A recommended method is to make the cut very slightly undersize and use a wood rasp or file to finish the

edge to exact size. Set loudspeaker over smaller hole so that mounting bolt circle is centered in the loudspeaker mounting holes. Be sure loudspeaker is rotated to exact orientation desired. Carefully mark location of each bolt hole and remove loudspeaker. Be sure to mark all eight hole positions. Use an appropriate drill to bore holes to accept shafts of appropriate size T-nuts:

T-nut Size	Drill Size
1/4"-20	5/16" (0.312)

Remove all debris from holes, edges and enclosure. Insert all 8 T-nuts in mounting holes, according to front or rear loudspeaker mounting option (see Figures 8 and 9). Gently hammer each T-nut in place until face of T-nut is flush with baffle surface. Install loudspeaker and secure with 8 bolts, observing CAUTION mentioned above.

CROSSOVER NETWORK CONTROLS

To use the network as a high frequency attenuator, press the EQ pushbutton to the 'out' position (push to release). The lower control (H.F. ATTN.) then operates as a high frequency attenuator. Maximum attenuation of high frequency is at the full counter clockwise position. The upper control has no

influence on the frequency response in this mode of operation.

To use the network as a dual equalizer, press the EQ pushbutton to the 'in' position. The upper control affects the high frequency range, and the lower control affects the mid frequency range.

ARCHITECT'S AND ENGINEER'S SPECIFICATIONS

604-8K DUPLEX® LOUDSPEAKERS

The loudspeaker shall be a Duplex® type with a 16-inch low-frequency cone driver coaxially mounted with a 1.0-inch high-frequency compression driver and 60° by 40° Mantaray® constant directivity horn. The Duplex® loudspeaker shall meet the following criteria. AES power rating shall be 75 watts of band limited pink noise (60 Hz to 20 kHz, 6 dB crest factor). Frequency response, uniform from 60 Hz to

20 kHz. Pressure sensitivity, 98.5 dB SPL at 1 meter on axis with one watt of band-limited pink noise from 500 Hz to 3 kHz (ref. 20 μPa). Minimum impedance, 8.5 ohms. The loudspeaker shall be 16.0 in (40.64 cm) in diameter and 18.2 in (22.38 cm) deep and shall weigh 34.0 lbs (15.4 kg) [including the crossover network].

The Duplex® loudspeakers shall be the Altec Lansing model **604-8K**.

NETWORK INSTALLATION FIGURES

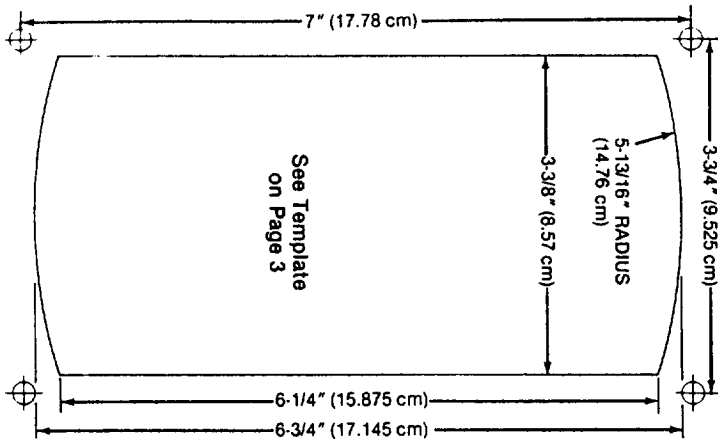

Figure 7 Cutout Dimensions for Network

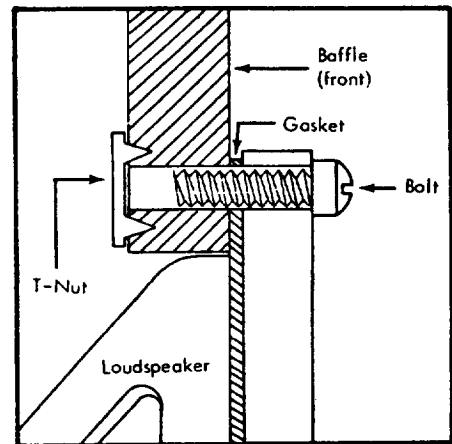

Figure 8 Front Mounted Loudspeaker

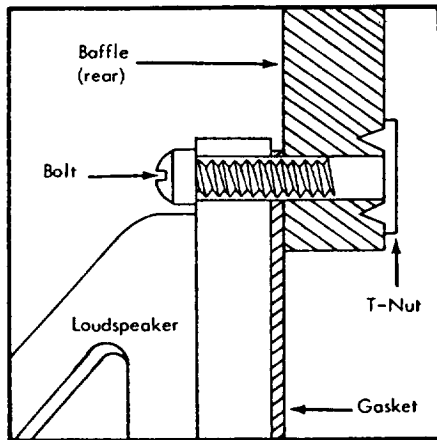

Figure 9 Rear Mounted Loudspeaker

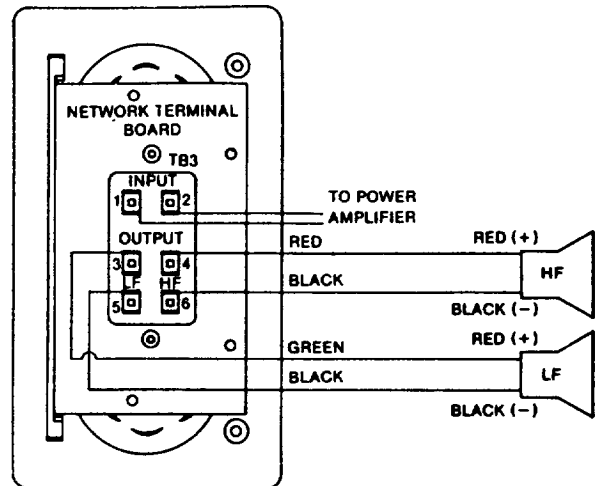

Figure 10 Wiring of 604-8K Duplex Loudspeaker System



a MARK IV company

P.O. BOX 26105 ● OKLAHOMA CITY, OK 73126-0105 ● U.S.A. ● (405) 324-5311 or FAX: (405) 324-8981
© 1992 ALTEC LANSING CORPORATION



SPECIFICATIONS

Type:	Duplex coaxial with network	Frame:	Die-cast aluminum
Power Rating:	65 watts continuous pink noise (20-20,000 Hz)	Dividing Network (furnished):	Dual full section with 1500 Hz cross-over frequency, LF slope 12 dB/octave, HF slope 18 dB/octave with shelving control/dual band equalizer
Frequency Response:	Uniform, 20-20,000 Hz	Dimensions:	16" (40.64 cm) diameter x 18-3/16" (22.38 cm) deep
Pressure Sensitivity:	100 dB SPL at 4' with 1 watt input of pink noise from 100-10,000 Hz in Altec 620B enclosure	Weight:	34 lbs. (15.42 kg) includes network
Impedance:	8Ω	Finish:	Dark grey enamel
Nominal Free-Air LF Cone Resonance:	30 Hz	Mounting Data — Baffle Opening:	14-1/8" (35.87 cm) diameter
Distribution Pattern:	Constant directivity Mantaray Horn 60°H x 40°V	Mounting Bolt Centers:	8 mounting bolts 45° apart on 15" (38.1 cm) diameter circle
Voice Coils — LF:	3" diameter, edge-wound copper ribbon	Recommended Enclosures:	Request document AN-11, Construction Plans for Low-Frequency Enclosures, from the Altec Literature Department.
HF:	1 3/4" diameter, edge-wound aluminum ribbon		
Magnets — LF:	5.6 lbs. ferrite 13,000 gauss		
HF:	2.5 lbs. ferrite 15,500 gauss		

DESCRIPTION

The Altec Lansing 604-8K Duplex Loudspeaker System consists of a two-way coaxial loudspeaker and a dividing network with dual equalization (mid and high frequencies). The loudspeaker incorporates recent advances in design that provide uniform frequency response from 20 to 20,000 Hz, and uniform dispersion at all audio frequencies. Network controls can be used in an equalization mode for separate control of mid and high frequency attenuation, or in a standard mode as a high frequency attenuator.

ENCLOSURE

The enclosure or baffle separates the sound radiated from the rear of the loudspeaker to prevent cancellation of radiation from the front of the loudspeaker. The enclosure is designed as a component of an acoustical system. The 604-8K Duplex Loudspeaker System cannot be expected to perform efficiently if housed in an inferior enclosure. For detailed enclosure construction plans, request document AN-11 from the Altec Literature Department.

NETWORK INSTALLATION

Networks are installed with T-nuts and bolts to a surface having a cutout of the dimensions shown in Figure 1. Use the template given at the end of these instructions to facilitate installation.

To make the cutout, first fix the template to the surface where the network is to be mounted. Use a $7/32"$ (0.218) drill to bore four holes to accept shafts of 8-32 T-nuts. A recommended method to make the cutout is to cut slightly undersize and use a wood rasp or file to finish the edges to exact size. Remove all debris from the holes, from the

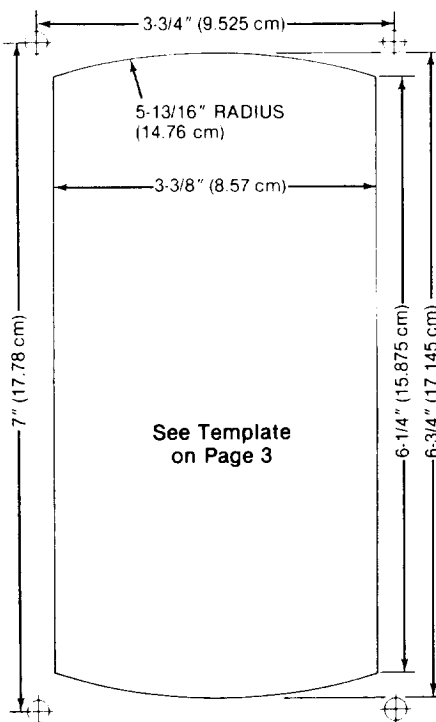

Figure 1. Cutout Dimensions for Network

cut edges, and from within the enclosure. Insert four T-nuts in mounting holes, from the inner side of the enclosure. Gently hammer each T-nut in place, until the faces of the T-nuts are flush with the surface. Insert the network in the cutout and secure with four 8-32 bolts. Prior to inserting the network, it may be desirable to connect system wiring to the terminals; refer to wiring diagram of Figure 4.

LOUDSPEAKER INSTALLATION

The loudspeaker is installed with T-nuts and bolts to a baffle having a cutout and mounting bolt pattern as listed in the table of specifications.

The loudspeaker may be front or rear mounted. Front mounting is recommended for best performance. A baffle of $3/4"$ particle board or plywood which is free of voids is recommended. Secure the loudspeaker to the baffle with eight bolts, with the loudspeaker oriented so that the MANTARAY designation reads horizontally. If only four mounting bolts are used, they should secure the loudspeaker at the mounting holes nearest the frame members.

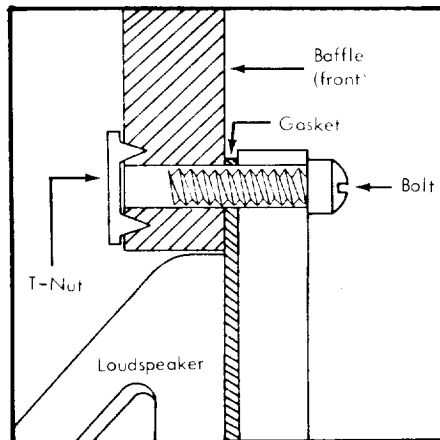

Figure 2. Front Mounted Loudspeaker

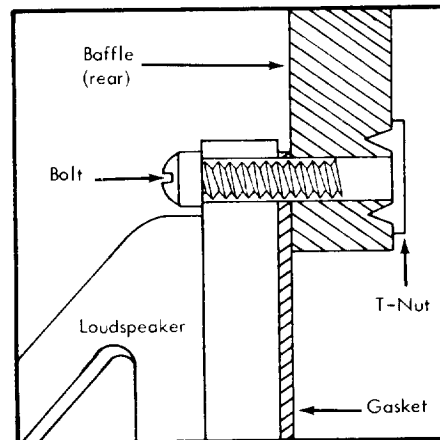

Figure 3. Rear Mounted Loudspeaker

CAUTION

Do not overtighten mounting bolts. Tighten bolts just enough so that there are no air leaks around loudspeaker flange. Do not tighten bolts with such force that loudspeaker frame is forced out of alignment. Tighten bolts evenly, a little at a time, moving around the circle as many times as necessary.

To make the loudspeaker cutout, locate and scribe circles for the loudspeaker hole and the mounting bolts. See table of specifications for dimensions. Cut out the smaller circle (loudspeaker hole). A recommended method is to make the cut very slightly undersize and use a wood rasp or file to finish the edge to exact size. Set loudspeaker over smaller hole so that mounting bolt circle is centered in the loudspeaker mounting holes. Be sure loudspeaker is rotated to exact orientation desired. Carefully mark location of each bolt hole and remove loudspeaker. Be sure to mark all eight hole positions. Use an appropriate drill to bore holes to accept shafts of appropriate size T-nuts:

T-Nut Size	Drill Size
1/4"-20	5/16" (0.312)
10-32	15/64" (0.234)
8-32	7/32" (0.218)

Remove all debris from holes, edges and enclosure. Insert all 8 T-nuts in mounting holes, according to front or rear loudspeaker mounting option (see Figures 2 and 3). Gently hammer each T-nut in place until face of T-nut is flush with baffle surface. Install loudspeaker and secure with 8 bolts, observing CAUTION mentioned above.

WIRING

Make wiring connections as shown in Figure 4. Ordinary commercial 18-gauge, stranded, insulated wire may be used for connection of the loudspeaker and network. This is considered minimum size wire for loudspeaker/amplifier connections up to 30 feet. For wire runs longer than 30 feet, 16 gauge or larger diameter wire is recommended.

LOUDSPEAKER POWER CAPACITY

The power capacity of ALTEC high fidelity loudspeakers is rated with reference to integrated program material. Isolated transients can be handled up to several times the indicated power capacity. Steady state sine wave signals should be held to not more than 10% of specified power level capacities.

CAUTION

Never connect the loudspeaker to 120 volt, 50/60 Hz line power (house current). This will damage the loudspeaker.

DIVIDING NETWORK CONTROLS

To use the network as a high frequency attenuator, press the EQ pushbutton to the 'out' position (push to release). The lower control (H.F. ATTN.) then operates as a high frequency attenuator. Maximum attenuation of high frequency is at the full counter-

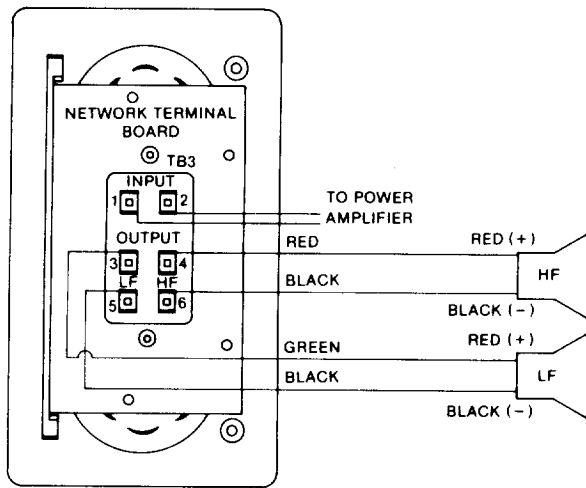

Figure 4. Wiring of 604-8K Duplex Loudspeaker System

NOTICE
 REPAIR PERFORMED BY OTHER THAN AUTHORIZED WARRANTY STATIONS (DEALERS) OR OTHER QUALIFIED PERSONNEL SHALL VOID THE WARRANTY PERIOD OF THIS UNIT. TO AVOID LOSS OF WARRANTY, SEE YOUR NEAREST ALTEC AUTHORIZED DEALER OR CALL ALTEC CUSTOMER SERVICE DIRECTLY AT (405) 324-5311, OR WRITE: CUSTOMER SERVICE/REPAIR, 10500 WEST RENO, OKLAHOMA CITY, OKLAHOMA 73128.

For factory service, ship the unit prepaid to ALTEC Customer Service/Repair, 10500 West Reno, Oklahoma City, Oklahoma 73128. For application, service or repair information, call (405) 324-5311

clockwise position. The upper control has no influence on the frequency response in this mode of operation.

To use the network as a dual equalizer, press the EQ pushbutton to the 'in' position. The upper control affects the high frequency range, and the lower control affects the mid frequency range.

STEREO PHASING

Proper system acoustic phasing of the left and right loudspeaker units in a home stereo music system or a recording studio monitor system is essential. Many elaborate methods for determining correct phase are available. This can be done easily in the home or studio by making a simple test.

Listen to the system in the monophonic mode, or with a mono sound source. The sound should seem to emanate directly from a point between the speaker systems. If any stereo effect is still heard, reverse the polarity of one system; this should restore the apparent sound source to the single desired point. When the sound appears to be at this mid-point in the mono mode, it will have the correct acoustic phasing for stereo.

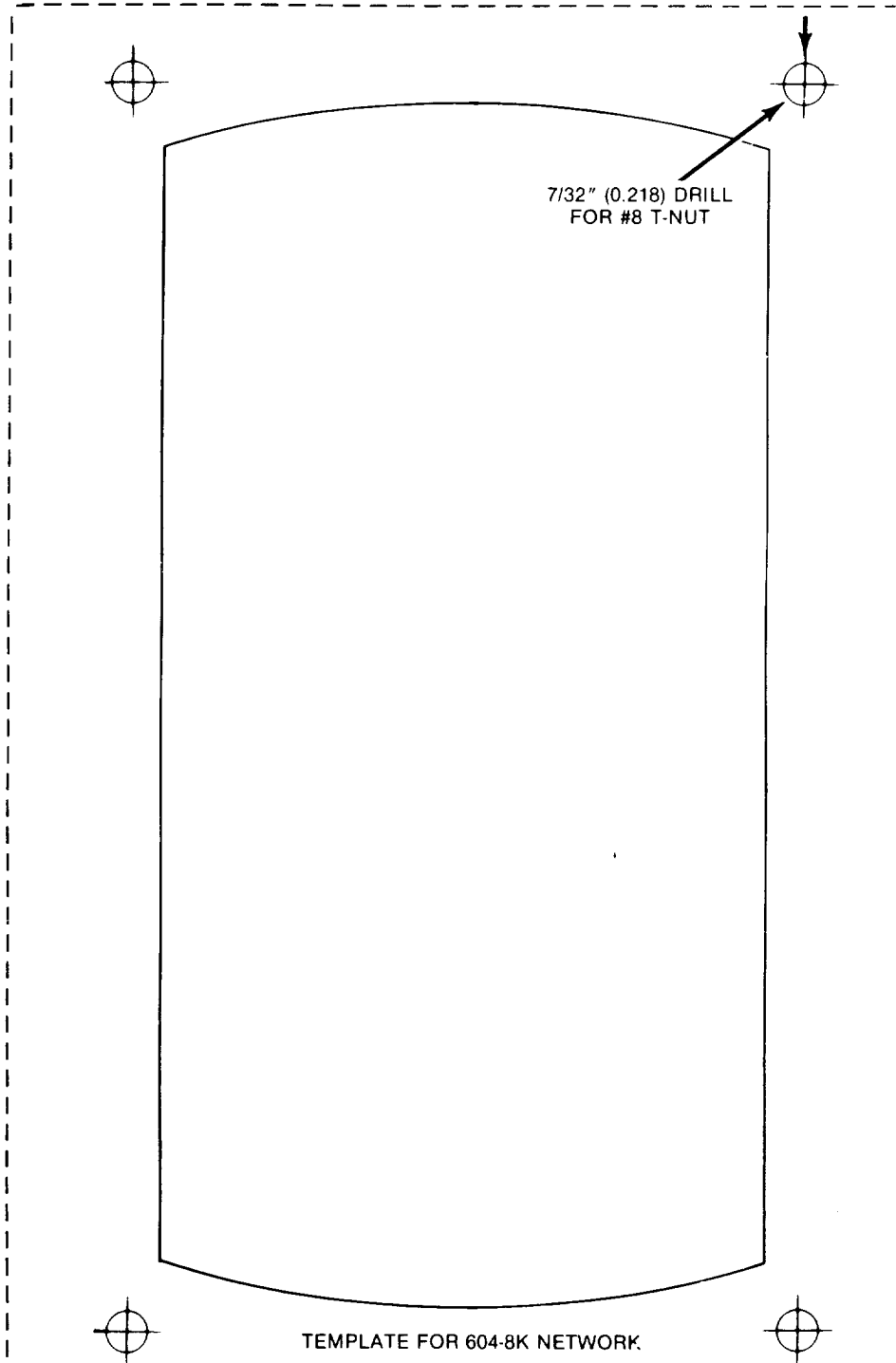

TEMPLATE FOR 604-8K NETWORK