

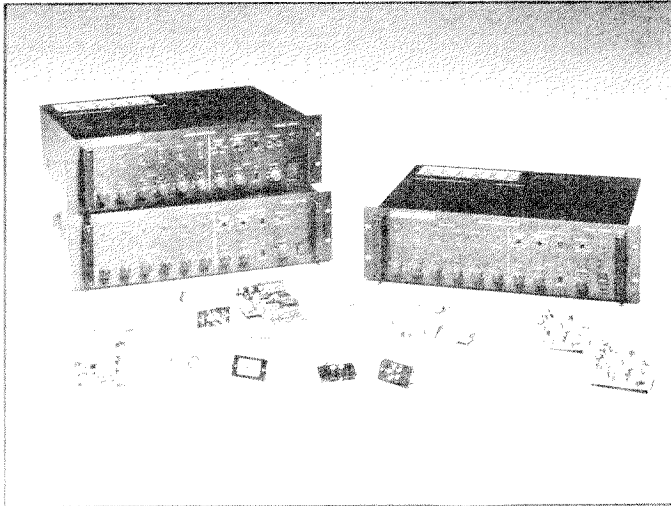

1700C Six Channel Mainframe Mixer/Preamplifier



KEY FEATURES

- ★ Six ports for inputs or outputs
- ★ Offers systemwide remote muting
- ★ Built-in compressor/limiter

The Altec Lansing 1700C Mixer/Preamplifier is a six channel user-configurable mainframe preamplifier. By selecting from the large array of system component options, the 1700C can become a six-in/one-out microphone mixer or a one-in/six-out distribution preamplifier.

The basic mainframe has six ports which can be input or output. When configuring with Altec Lansing's 1780A/AT or 1781A/AT Programmable Input modules, the mainframe becomes a powerful six channel mixer. Multiple 1700C mainframes can be linked together for situations where more than six input/output ports are required.

Built-in features include a top panel trap-door for easy access into the unit, compressor/limiter, low and high frequency shelving equalizers, muting, remote volume control capability, and a tone generator which produces four different sounds.

KEY SYSTEM SPECIFICATIONS

Frequency Response: (Ref. 1 kHz)

Main Output:	± 1 dB, 20 Hz - 20 kHz (Ref. 1 kHz, +10 dBm output)
Preamp Output:	± 1 dB, 20 Hz - 20 kHz (Ref. 1 kHz, 0.775 Vrms, 10 k Ω load)
Link Output:	± 1 dB, 20 Hz - 20 kHz (Ref. 1 kHz, 100 mVrms, 10 k Ω load)

Total Harmonic Distortion (THD):

Main Output:	<0.03%, 20 Hz - 20 kHz (Ref. +10 dBm output, EQ flat, compressor/limiter off, 30 kHz low-pass filter)
Preamp Output:	<0.03%, 20 Hz - 20 kHz (Ref. 1 kHz, 0.775 Vrms output, 10 k Ω load, EQ flat, compressor/limiter off, 30 kHz, low-pass filter)
Link Output:	<0.03%, 20 Hz - 20 kHz (Ref. 1 kHz, 100 mVrms output, 10 k Ω , 30 kHz low-pass filter)

DESCRIPTION

Input Modules: The Altec Lansing 1780A/1780AT Input module and the 1781A/1781AT Programmable Input module accept either mic or line level signals through a wide variety of connector interfaces. Further detail on these modules is given later in this document.

Output Modules: The Altec Lansing 1783 Line Output module allows the user to interface with other professional equipment. Further detail on this module is given later in this document.

The Altec Lansing model 1700C mixer/preamplifier systems respond to most design tasks with the ease and versatility of systems costing much more. As a result, it is *the choice* for use in professional installations requiring high quality, flexibility in design, and low cost.

1700C Specifications (cont'd)

Rated Output Level:	(Ref. 1 kHz)	Rear Panel Controls:	
Main Output:	(balanced, LINE position) +10 dBm (balanced, MIC position) -40 dBm	Tone Generator:	1 - Output Level adjust (screwdriver slotted)
Preamp Output:	(unbalanced) 0 dBm	Output:	1 - Output level select switch (MIC or LINE)
Link Output:	(unbalanced) 100 mVrms (-18 dBu), 10 kΩ load	Indicators:	
Signal-to-Noise Ratio:		Front Panel:	6 - Green LED's (Nominal Input level) 6 - Red LED's (Peak Input level) 1 - Red LED (Main Output clip) 1 - AC Power ON
Main Output:	>85 dB (rated output, A-weighted, EQ defeated, compressor/limiter off)	Connectors:	
Preamp Output:	>75 dB (rated output, A-weighted, EQ defeated, compressor/limiter off)	Inputs:	
Link Output:	>75 dB (rated output, A-weighted)	Link Input:	1 - RCA phono receptacle
Minimum Load Impedance:		Battery:	1 - 3-terminal barrier strip
Main Output:		Outputs:	
Line Level balanced:	600 Ω minimum	Main Output:	1 - Male XLR connector 1 - 3-terminal barrier strip
Mic Level balanced:	600 Ω minimum	Preamp Output:	1 - RCA phono receptacle
Preamp Output:		Control:	
unbalanced:	600 Ω minimum	Mute and Tone Generator:	Screw terminals (7)
Link Output:		Power Requirements:	(Ref. 1 kHz, rated output with no modules installed)
unbalanced:	2 kΩ minimum	AC Mains:	100, 120, 200, 220 or 240 VAC, 50/60 Hz
Equalization:	(Shelving type)	Battery:	±48 VDC bipolar, 0.5 amps maximum
Bass:	±12 dB at 100 Hz	Power Consumption and Heat Produced:	17 watts consumed, 57.5 BTU/hour
Treble:	±12 dB at 10 kHz	Operating Temperature Range:	Up to 50°C (122°F)
Compressor/Limiter:	Feedforward Topology	Dimensions:	
Threshold:	-20 dB to +20 dB Continuously variable (Ref. 100 mVrms on Link input)	Width:	19 inches (48.3 cm)
Compression Ratio:	1:1 to ∞:1	Height:	5¼ inches (13.3 cm) (3 standard rack units)
Release Time:	50 msec to 5 sec. Continuously variable	Depth:	13 inches (33.0 cm)
Tone Generator:	Electronically produced	Net Weight:	15 lbs. (6.8 kg)
Tones:	Buzzer, siren, single-tone chime, and repeating tone chime	Finish Color:	Black
Control:	All tones are initiated by external switch closures	Accessories Included with Mainframe:	
Level Adjustment:	Rear panel	1 - Operating/Service Instructions for Mainframe, 1780A/AT, 1781A/AT and 1783	
Front Panel Controls:		4 - Rubber Feet (installed)	
Input:	6 - Input Level adjust	1 - System Configuration Label installed on top cover	
EQ Controls:	1 - Bass adjust 1 - Treble adjust 1 - EQ In/Defeat switch	1 - International 220/240 VAC voltage decal	
Output:	1 - Master Level adjust	1 - International Fuse decal	
Compressor/Limiter:	1 - Release Time adjust (screwdriver slotted) 1 - Threshold adjust (screwdriver slotted) 1 - Compression Ratio adjust (screwdriver slotted) 1 - On/Off switch	1 - Fuse for International use	
Miscellaneous:	1 - AC Power switch	1 - Rack mount hardware kit	

Altec Lansing continually strives to improve their products and performance. Therefore, specifications are subject to change without notice.

1780A/1780AT

Description

The **Altec Lansing 1780A/1780AT** Mic/Line Input modules combine basic microphone preamplification with true line level input capability. The module has a built-in resistive pad to permit levels in excess of 0 dBu and its high input impedance easily allows sixteen modules to be driven from a single low impedance source. Also, the module offers a 300 Hz high-pass filter, phantom power capability, L + R stereo summing, and 0 to 50 dB of continuously variable gain. Included in the **1780AT** version is a 10 k Ω input bridging transformer for those who prefer transformer isolation.

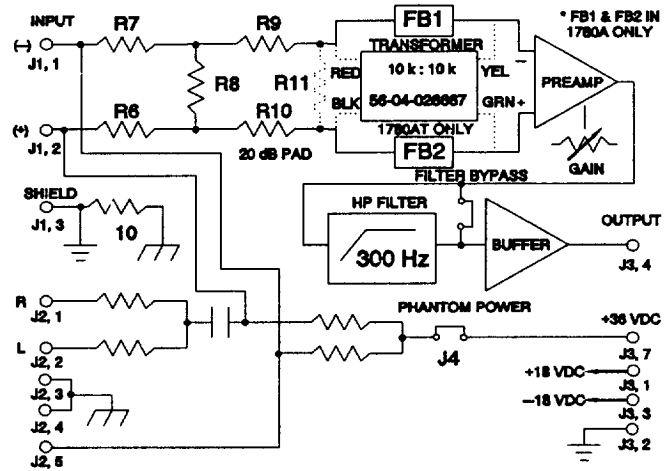

Block Diagram of the 1780A/1780AT Input Module

1780A/1780AT Specifications

Gain:	0 - 50 dB, continuously variable	High Pass Filter:	
		Corner Frequency:	300 Hz
		Slope:	12 dB/octave
Input Sensitivity:		Controls:	1 - Gain, continuously variable
Without Pad:	-68 dBu to -18 dBu (.3 mVrms to 100 mVrms)		
With Pad:	-48 dBu to +2 dBu (3 mVrms to 1 Vrms)		
Input Impedance:		Weight (Net):	
1780A:	10 k Ω	1780A:	2.5 oz. (70 g)
1780AT:	10 k Ω	1780AT:	3.0 oz. (85 g)
With 1793 Dual Phono:	40 k Ω	Power Supply Requirements:	\pm 18 VDC at 15 ma DC (supplied by mainframe)
Frequency Response:	50 Hz - 20 kHz, \pm 1 dB	Included Accessories:	1 - 2-pin female jumper (for phantom power) 2 - mounting screws (for potentiometer bracket) 1 - Operating Instructions
Total Harmonic Distortion:	(Ref. minimum gain, 50 Hz - 20 kHz measurement bandwidth, 30 kHz low-pass filter)		
1780A:	<0.01%		
1780AT:	<0.025%		
Equivalent Input Noise:	<-120 dBr (Ref. 0 dBr = 100 mVrms out- put, 10 k Ω load, 200 Ω input termination, maximum gain, A-weighted)		

1781A/1781AT

Description

The Altec Lansing 1781A/1781AT Programmable Input modules accept either mic or line level signals through a wide variety of connector interfaces. Standard features include an electronically balanced input stage with adjustable gain, continuously variable high and low pass filters, RFI protection, 48 volt phantom powering two levels of muting, and remote volume control capability. Programming with plug-in jumpers which may select phantom power (on or off), mute priority or slave, or remote volume control. The 1781AT module also comes equipped with a 1785A Input Isolation Transformer which provides an additional 10 dB of gain for improved sensitivity.

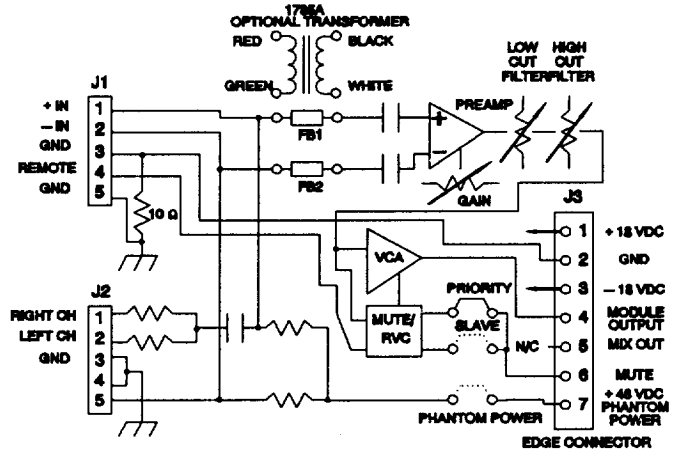

Block Diagram of the 1781A/1781AT Input Module

1781A/1781AT Specifications

Gain:		Total Harmonic Distortion (THD):	
1781A:	0 dB - 50 dB, continuously variable	20 Hz - 20 kHz:	(Ref. 1 kHz, 100 mVrms output, minimum gain, 10 kΩ load, 30 kHz low pass filter) <0.03%
1781AT:	10 dB - 60 dB, continuously variable		
Input Sensitivity:	(Ref. 1 kHz, 10 kΩ load)	Equivalent Input Noise:	(Ref. 0 dB = 100 mVrms output, 10 kΩ load, 200 Ω input termination maximum gain, A-weighted) <-120 dB
1781A:	-60 dBu to -18 dBu (0.3 mVrms - 100 mVrms)		
1781AT:	-78 dBu to -28 dBu (0.1 mVrms - 30 mVrms)		
Input Impedance:	(Ref. 1 kHz)	High Pass Filter (Low Cut):	(Ref. 100 mVrms output, minimum gain, 10 kΩ load)
Electronically balanced:	>8 kΩ	Corner Frequency:	320 Hz
Transformer balanced:	200 Ω - 600 Ω	Slope:	>10 dB at 100 Hz 6 dB/oct (20 dB/dec)
With 1793 Dual Phono Connector Installed:	>39 kΩ		
Frequency Response:	(Ref. 1 kHz, 100 mVrms output, 10 kΩ load)	Low Pass Filter (High Cut):	(Ref. 100 mVrms output, minimum gain, 10 kΩ load)
1781A:		Corner Frequency:	5 kHz
±1 dB (minimum gain):	20 Hz - 20 kHz	Slope:	>6 dB at 10 kHz 6 dB/oct (20 dB/dec)
±1 dB (maximum gain):	50 Hz - 20 kHz		
1781AT:		Attenuation:	(Ref. 100 mVrms output, minimum gain, 10 kΩ load)
±1 dB (minimum gain):	20 Hz - 20 kHz	Mute:	>60 dB (10 kΩ remote)
±1 dB (maximum gain):	50 Hz - 15 kHz		

1783

Description

The **Altec Lansing 1783** Line Output modules provides the drive capability necessary to interface with other professional equipment. The electronically balanced output stage provides a low source impedance to drive subsequent stages. If transformer isolation is necessary, the module's circuit board accommodates the optional PC-mount **1786** Output Isolation Transformer. The continuously variable output level control is local to the module permitting independent adjustment of each line output.

1783 Specifications

Output Source Impedance:	<50 Ω
Nominal Output Level /Load Impedance:	+8 dBm (Ref. 1 kHz, 0 dBm = 0.775 Vrms with 600 Ω load, output level control at maximum, 100 mVrms input)
Maximum Output Level:	+24 dBm
Frequency Response: ± 1 dB:	(Ref. 1 kHz, +8 dBm output) 20 Hz - 25 kHz
Total Harmonic Distortion (THD): 20 Hz - 20 kHz:	(Ref. 1 kHz, +8 dBm output, output level control at maximum, 30 kHz low pass filter) <0.05%
Signal to Noise Ratio:	>88 dBm (Below +8 dBm output, output level control at maximum, A-weighted)
Power Requirements:	± 18 VDC at 20 mA (supplied by mainframe)
1786 Output Isolation Transformer	
Impedance Ratio:	1:1 (600 Ω :600 Ω)
Frequency Response: ± 1 dB:	(Ref 1 kHz, +18 dBm output) 20 Hz - 20 kHz
Total Harmonic Distortion (THD): 20 Hz - 20 kHz: 50 Hz - 20 kHz:	Ref 1 kHz, +18 dBm output) <0.5% <0.1%

Special Ordering Instructions

NOTE: The modules listed below are required for use with the **1700C** and must be ordered separate from the mainframe.

Plug-in Input Modules:

- 1780A** Mic/Line Input module
- 1780AT** Mic/Line Input module with 10 k Ω bridging transformer installed
- 1781A** Programmable Input module
- 1781AT** Programmable Input module with model **1785A** 600 Ω to 10 k Ω isolation transformer installed
- 1785A** 600 Ω to 10 k Ω Input Isolation Transformer for installation on existing model **1781A**

Plug-in Output Module:

- 1783** Line Output module
- 1786** Output Isolation Transformer

Plug-in EQ Module:

- 8751A** Programmable 14-Band EQ module

NOTE: Each module selected requires one of the following connectors also be ordered:

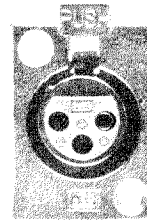

1791
Female XLR

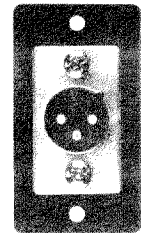

1792
Male XLR

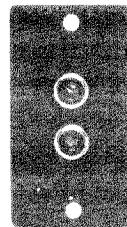

1793
Dual RCA Phono

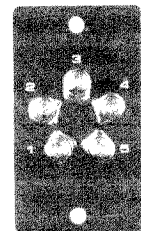

1794
5-Lug Terminal

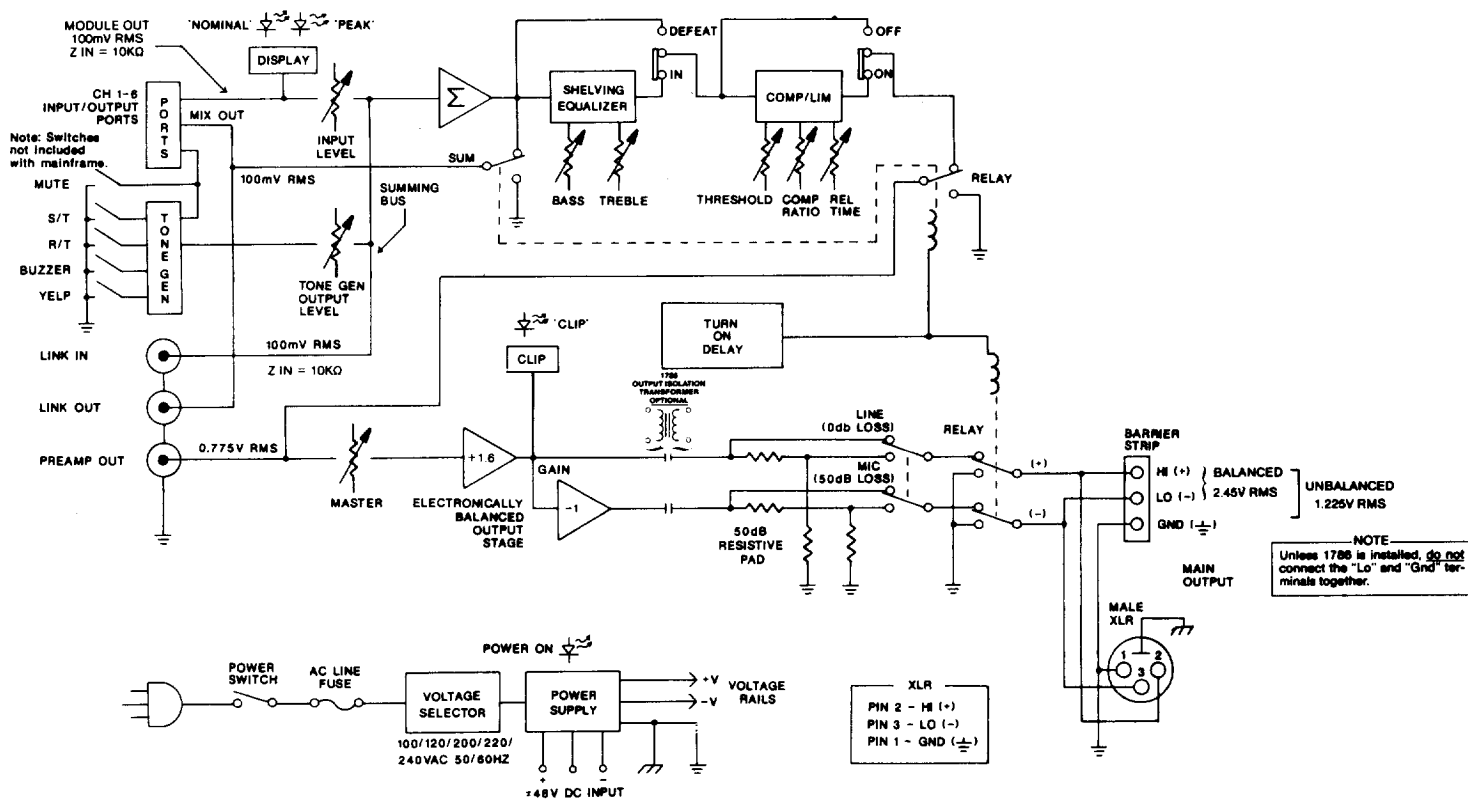

1700C System Block Diagram

ARCHITECT'S and ENGINEER'S SPECIFICATION

The mixer/preamplifier shall have six configurable ports and be capable of operating from 100, 120, 200, 220, or 240 Vac, 50/60 Hz line, or from ± 48 VDC. Each port shall be usable with a microphone or other high level device. The mixer/preamplifier mainframe shall include a compressor/limiter, low and high frequency shelving equalizers, and a tone generator capable of producing general purpose and emergency warning signals.

The preamplifier shall meet the following performance criteria: Frequency Response: 30 Hz to 20 kHz, ± 1 dB (main output). Source Impedance: 150 Ω to 250 Ω nominal with a microphone preamplifier, 600 Ω with a bridging transformer, 150 Ω to 600 Ω with a line matching transformer, and greater than 30 k Ω with a tape preamplifier. Equivalent Input Noise: < -120 dB with a low impedance microphone

preamplifier. Output Noise: < -85 dBm (with all controls off).

The mixer/preamplifier shall be rack mountable and finished in black. The amplifier's dimensions shall be 5 $\frac{1}{4}$ " (H) x 19" (W) x 12 $\frac{1}{4}$ " (D) and its net weight shall be 24.2 lbs.

The plug-in accessory modules shall be the 1780A/AT and the 1781A/AT Input modules and the 1783 Line Output module. The accessory transformers usable with the modules shall be the 1785A Input Isolation transformer and the 1786 Output Isolation transformer. The connector subassemblies shall be the 1791 female XLR, 1792 male XLR, 1793 dual phono, and the 1794 5-lug screw terminal connector.

The mixer/preamplifier shall be the Altec Lansing Model 1700C.



a MARK IV company

P.O. BOX 26105 • OKLAHOMA CITY, OK 73126-0105 • U.S.A. • 405/324-5311 or FAX: 405/324-8981
© 1992 ALTEC LANSING CORPORATION

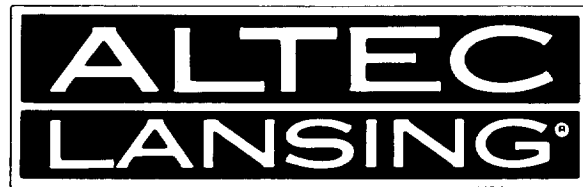

the sound of experience

1700C Mixer Preamp System

Operating and Service Instructions

ALTEC LANSING CORPORATION

a **MARK IV** company

P.O. Box 26105 • OKLAHOMA CITY, OK • 73126-0105 • 405-324-5311 or FAX 405-324-8981

Table of Contents

Section	Page
SPECIFICATIONS	3-4
1.0 ELECTRICAL CONNECTIONS	5
1.1 120 Volt, 50/60 Hz Power Connections	5
1.2 100, 200, 220, 240 Volt, 50/60 Hz Power Connections	5
2.0 INSTALLING THE MODULES IN THE MAINFRAME	6
3.0 SHELF OR RACK MOUNTING THE 1700C	7
3.1 Ventilation	7
4.0 CONFIGURING THE 1700C	7
4.1 The Inner Workings of the 1700C	7
4.2 Main Output Connections	8
4.2.1 The MIC/LINE Switch	8
4.3 Mute/Tone Generator Connections	8
4.3.1 Resistance Effects of Long Cable Runs on the Mute and Tone Generator Circuitry	8
4.4 Link In/Link Out Connections	9
4.5 Preamp Out Connections	9
4.6 Battery Input Connections	9
5.0 INITIAL SETUP AND OPERATION OF THE 1700C MIXER/PREAMPLIFIER WITH INPUT AND OUTPUT MODULES INSTALLED	10
5.1 Initial Setup of an Input Module	10
5.2 Initial Setup of an Output Module	10
5.3 1700C Initial Setup	10
5.4 Operating the 1700C Mixer/Preamplifier System	10
6.0 SERVICE INFORMATION	12
6.1 Parts Odering	12
6.2 Factory Service	12
6.3 Technical Assistance	12
7.0 PARTS LIST	14-16
8.0 SCHEMATIC	18-19

Description

The 1700C Mixer / Preamplifier System offers a highly flexible and user configurable six input mixer in a cost effective package.

The six input ports accept any of the several input modules or the available output module. The programmable input modules may be configured in either "priority" or "slave" modes or may be set to ignore muting commands. When a module configured in the "Priority" mode is activated, modules configured in the "slave" mode will be muted. Each input channel has dual LED's to indicate nominal and peak input signal levels making setup and correct adjustment very easy. Circuitry is provided on the

programmable input module to allow remote volume control of individual inputs.

The output module allows a line level signal to be sent to remote systems independently of the main output.

A fully adjustable feedforward type compressor / limiter is included. Shelving type equalization and a multi-tone generator are also provided.

Multiple mainframes may be dynamically linked together to provide more than six inputs. This is also useful in situations where multiple outputs with independent controls are desired.

Specifications

Frequency Response:		Rated Output Level:	(Ref. 1 kHz)
Main Output:	±1dB, 20 Hz – 20 kHz (Ref. 1 kHz, +10 dBm output, 600 Ω load)	Main Output:	(balanced, LINE position), +10 dBm, 600 Ω load.
Preamp Output:	±1dB, 20 Hz – 20 kHz (Ref. 1 kHz, 0.775 Vrms, 10 kΩ load)	Main Output:	(balanced, MIC position), -40 dBm, 600 Ω load.
Link Output:	±1dB, 20 Hz – 20 kHz (Ref. 1 kHz, 100 mVrms, 10 kΩ load)	Preamp Output:	(unbalanced), 0 dBu, 10 kΩ load.
Total Harmonic Distortion (THD):		Link Output:	(unbalanced), 100 mVrms (-18dBu), 10 kΩ load.
Main Output:	<0.03%, 20 Hz – 20 kHz (Ref. +10 dBm output, EQ flat, compressor/limiter off, 30 kHz low-pass filter)	Minimum Load Impedance:	
Preamp Output:	<0.03%, 20 Hz – 20 kHz (Ref. 1 kHz, 0.775 Vrms output, 10 kΩ load, EQ flat, compressor/limiter off, 30 kHz low-pass filter)	Main Output	Line Level Balanced: 600 Ω minimum.
Link Output:	<0.03%, 20 Hz – 20 kHz (Ref. 1 kHz, 100 mVrms output, 10 kΩ load, 30 kHz low-pass filter)	Main Output	Mic Level balanced: 600 Ω minimum.
Input Sensitivity:	(Ref. 1 kHz)	Preamp Output	unbalanced: 600 Ω minimum.
Using 1780A/1780AT:	0.3 to 100 mVrms (balanced, no pad) (-68 dBu to -18 dBu)	Link Output	unbalanced: 2 kΩ minimum.
Using 1780A/1780AT:	3 mVrms to 1 Vrms (balanced, w/pad) (-48 dBu to +2 dBu)	Signal to Noise Ratio:	
Using 1781A:	0.3 to 100 mVrms (balanced) (-68 dBu to -18 dBu)	Main Output:	> 85 dB re: rated output. A weighted, EQ defeated, compressor/limiter off.
Using 1781AT:	0.1 to 30 mVrms (balanced) (-78 dBu to -28 dBu)	Preamp Output:	> 75 dB re: rated output. A weighted, EQ defeated, compressor/limiter off.
Using 1781A+1785A:	0.1 to 30 mVrms (balanced) (-78 dBu to -28 dBu)	Link Output:	> 75 dB re: rated output. A weighted.
Link Input:	100 mVrms (unbalanced) (-18 dBu)	Equalization:	Shelving Type.
Input Impedance:		Bass:	±12 dB at 100 Hz.
Using 1780A:	10 kΩ	Treble:	±12 dB at 10 kHz.
Using 1780AT:	10 kΩ	Compressor / Limiter:	Feedforward Topology
Using 1780A with 1793:	40 kΩ (Dual Phono)	Threshold:	-20 dB to +20 dB Continuously variable. (Ref. 100 mVrms on Link input.)
Using 1781A:	10 kΩ	Compression Ratio:	1:1 to ∞:1, Continuously variable.
Using 1781AT:	600 Ω	Release Time:	50 msec to 5 sec. Continuously variable.
Using 1781A + 1785A:	600 Ω	Tone Generator:	
Using 1781A with 1793:	40 kΩ (Dual Phono)	Tones:	Electronically produced Buzzer, siren, single-tone chime, and repeating tone chime.
		Control:	All tones are initiated by remote switch closures.
		Level adjustment:	Rear panel.

1.0 1700C ELECTRICAL CONNECTIONS

1.1 120 Volt, 50/60 Hz Power Connections

The mainframe is configured with the primary of the power transformer strapped for 120 volt operation from the factory. Refer to Table I. for the exact strapping details and other voltage options.

Table I. AC Line Voltage Selection and Strapping Options Chart

Primary Line Voltage	Transformer Primary Lead Color				
	WHITE	YELLOW	RED	BLUE	ORANGE
100V	5	2	11	9	3
120V	2	5	11	3	9
200V	5	2	7	10	8
220V	5	2	7	8	10
240V	2	5	7	8	10

The numbers in Table I correspond to the numbered positions on the AC terminal block connector near the power transformer. A line voltage is selected by installing the colored primary leads into the designated numbered positions on the terminal block.

NOTE

Verify that the line voltage is in accordance with the selected voltage **before connecting the mainframe to the AC line.**

1.2 100, 200, 220, and 240 Volt, 50/60 Hz Power Connections

The mixer/preamplifier may be powered from line voltages other than 120 volts by re-strapping the primary of the power transformer. Follow the procedures below to change the factory strapping to the desired line voltage.

1. Remove the nine screws, securing the top cover. There are two screws on each side, two screws on the top near the rear edge of the front panel, and three screws at the top edge of the rear panel. Refer to Figure 1 for details.

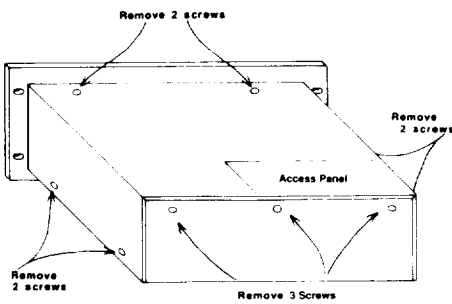

Figure 1. Top Cover Removal

2. Locate the voltage selection terminal block on the bottom of the chassis, near the power transformer. Refer to Figure 2.

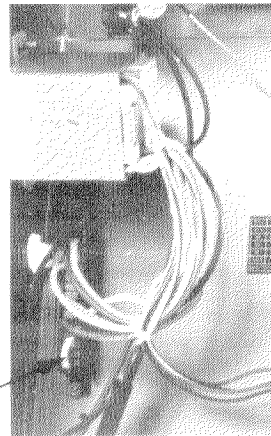

Figure 2. Location of Voltage Selection Terminal Block Inside Mainframe

3. While referring to Table I, disconnect the primary leads from the terminal block and reconnect each lead into its designated position on the terminal block corresponding to the desired line voltage. Pull each wire firmly to disengage the push-on connector. Press each connector firmly to snap into place.
4. Install the appropriate fuse value from Table II.

AC Line Voltage	AC Line Fuse (Type 3AG)
100V	300 mA/250 Volt
120V	300 mA/250 Volt
200V	150 mA/250 Volt
220V	150 mA/250 Volt
240V	150 mA/250 Volt

Table II.

NOTE

Use of fuses other than those listed in Table II will void the warranty.

If the power transformer's primary leads were connected for 200, 220, or 240 volt operation, perform Steps 5, 6, and 7 to prevent future confusion and possible damage to the amplifier. Otherwise, proceed with Step 8.

5. Affix the 220/240 VAC label above the power cord to cover the 120 VAC silkscreened designation.
6. Affix the fuse label over the original silkscreened designation. Refer to Figure 3.

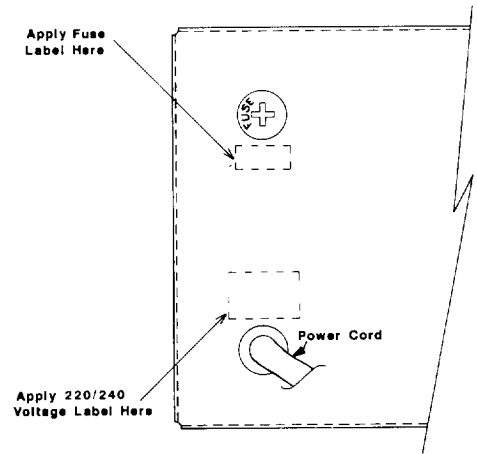

Figure 3. Application of International Voltage and Fuse Stickers

7. Replace the standard AC line fuse with the 150 mA fuse supplied in the plastic bag along with this manual.
8. If no modules are being installed at this time, re-install the top cover. Secure with the nine screws previously removed in Step 1.

Connectors:
Inputs:
 Link input: 1 – RCA phono receptacle
 Battery: 1 – 3-terminal barrier strip
Outputs:
 Main Output: 1 – Male XLR connector.
 1 – 3-terminal barrier strip.
 Preamp Output: 1 – RCA phono receptacle
 Link Output: 1 – RCA phono receptacle
Control:
 Mute and
 Tone Generator: Screw Terminals (7)

Front Panel Controls:
 Input: 6 Input Level adjust.
 EQ Controls: 1 Bass adjust.
 1 Treble adjust.
 1 EQ In/Defeat switch.
 Output: 1 Master Level adjust.
 Compressor/Limiter: 1 Release Time adjust.
 (screwdriver slotted)
 1 Threshold adjust.
 (screwdriver slotted)
 1 Compression Ratio adjust
 (screwdriver slotted)
 1 On/Off Switch.
 Miscellaneous: 1 AC Power switch.

Rear Panel Controls:
 Tone Generator: 1 Output Level adjust.
 (screwdriver slotted)
 Output: 1 Output level select
 switch. (MIC or LINE)

Indicators:
 Front Panel: 6 Green LED's, (Nominal
 Input Level).
 6 Red LED's, (Peak Input
 Level).
 1 Red LED, Main output
 CLIP).
 1 AC Power ON.

Microphone
Phantom Power: 48 VDC @ 200 milliamps
 consumption.

Power Requirements: (Ref. 1 kHz, rated output
 with no modules installed.)
 AC Mains: 100, 120, 200, 220 or
 240 VAC, 50/60 Hz.
 17 watts maximum.
 Battery: ±48 VDC bipolar,
 0.5 amps maximum.

**Power Consumption and
 Heat Produced:** 17 watts consumed.
 57.5 BTU/hour.

**Operating
 Temperature Range:** Up to 50°C (122°F)

Dimensions: Width: 19 inches (48.3 cm)
 Height: 5¼ inches (13.3 cm)
 3 standard rack units.
 Depth: 13 inches (33.0 cm)

Net Weight: 15 lbs. (6.8 kg)

Finish Color: Black

Accessories included with Mainframe:
 1 – Operating/Service Instructions for Mainframe,
 1780A/AT, 1781A/AT and 1783.
 4 – Rubber Feet (installed).
 1 – System Configuration Label installed on top
 cover.
 1 – International 220/240 VAC voltage sticker.
 1 – International Fuse sticker.
 1 – Fuse for International use.
 1 – Rack mount hardware kit.

Plug-in Input Modules:
Required – Order Separately
1780A Mic/Line Input Module.
1780AT Mic/Line Input Module with 10 kΩ
 bridging transformer installed.
1781A Programmable Input Module.
1781AT Programmable Input Module with
 model 1785A 600Ω to 10 kΩ isolation
 transformer installed.
Module Accessories:
1785A 600Ω to 10 kΩ Input Isolation
 Transformer for installation on model 1781A.

Plug-in Output Module:
Optional – Order Separately.
1783 Line Output Module.

IMPORTANT NOTE:
 Each module selected from the list above
 requires one of the following connectors also
 be ordered.
1791 Female XLR Connector.
1792 Male XLR Connector.
1793 Dual RCA Phono Connector.
1794 5-Lug Screw Terminals.

1786 Main Output Isolation Transformer:
Optional – Order separately.
 Nominal impedance: 600 Ω
 Impedance Ratio: 1:1
 Frequency Response: ± 1 dB,
 20 Hz to 20 kHz.
 THD: at +18 dBm output,
 <0.1%, 50 to 20 kHz.
 <0.5%, 20 to 20 kHz.
 Insertion Loss: 1 dB.

Plug-in Equalization Module:
Optional – Order Separately.
8751A Programmable 14 Band EQ Module.

Altec Lansing continually strives to improve their
 products and performance. Therefore, specifications
 are subject to change without notice.

2.0 INSTALLING THE MODULES IN THE MAINFRAME

1. Remove the two screws securing the access panel to the top cover. Refer to Figure 1 for details.
2. Plug the module into the desired channel position with the controls facing the rear as shown in Figure 4. Secure the module with the two screws provided.

3. Remove the blank cover panel as shown in Figure 5. Install the selected connector assembly with the screws provided. Plug the pigtail connector (from the main connector assembly) onto its appropriate male mating connector on the module's printed circuit board.
4. On the top cover is a **System Configuration Label**. Use it to indicate the module type, configuration, and options (if any) for future reference. Write directly on the label with a permanent marker. A sample label is shown in Figure 6 for reference.

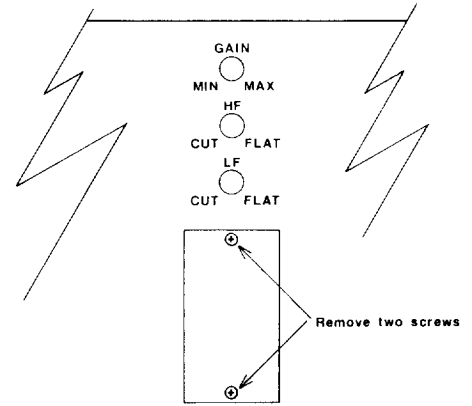

Figure 5. Removal of Blank Cover Panel

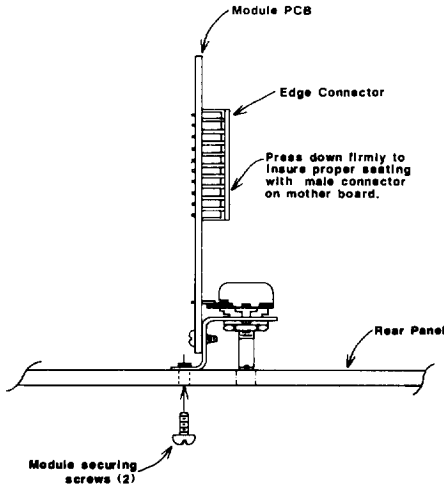

Figure 4. Module Installation

6	5	4	3	2	1
INPUT	INPUT	INPUT	INPUT	INPUT	INPUT
OUTPUT	OUTPUT	OUTPUT	OUTPUT	OUTPUT	OUTPUT
NONE	NONE	NONE	NONE	NONE	NONE
MUTE SLAVE	MUTE SLAVE	MUTE SLAVE	MUTE SLAVE	MUTE SLAVE	MUTE SLAVE
PRIORITY	PRIORITY	PRIORITY	PRIORITY	PRIORITY	PRIORITY
XFORMER	XFORMER	XFORMER	XFORMER	XFORMER	XFORMER
RVC	RVC	RVC	RVC	RVC	RVC
+4 dBm	0 dBm		Phantom Pwr		

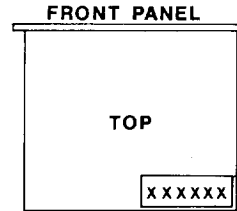

Figure 6. Sample System Configuration Label

3.0 SHELF OR RACK MOUNTING THE 1700C

The mainframe may be either shelf or rack mounted. For shelf or countertop applications, four rubber feet are provided to protect the resting surface. For rack or cabinet applications, remove the four rubber feet from the bottom of the chassis and install the unit in the rack with the screws and shoulder washers provided.

3.1 Ventilation

The preamplifier should not be sandwiched between other heat producing equipment or in areas where the ambient temperature exceeds 50°C (122°F).

If the mainframe is mounted in an equipment rack or cabinet with other equipment, a 1 3/4 in. (4.45 cm) space **must** be provided above and below the unit.

In a rack or cabinet containing several amplifiers, the acceptability of the air temperature may be in question. To determine the ambient air temperature, operate the system until the temperature stabilizes. Measure the ambient air with a bulb-type thermometer held at the bottom of the uppermost amplifier.

CAUTION

If the air temperature exceeds 50° C (122°F), place the equipment farther apart or install a blower to provide air movement within the cabinet. Make sure you don't block the air-intake holes located on the bottom of the chassis or the exhaust holes on the top cover.

CAUTION

Don't let the thermometer bulb touch the metal chassis. The chassis might be hotter than the ambient air.

4.0 CONFIGURING THE 1700C

4.1 The Inner Workings of the 1700C

A block diagram of the mixer/preamplifier mainframe is shown in Figure 7. A good understanding of the system is mandatory if it is to be utilized to its fullest extent.

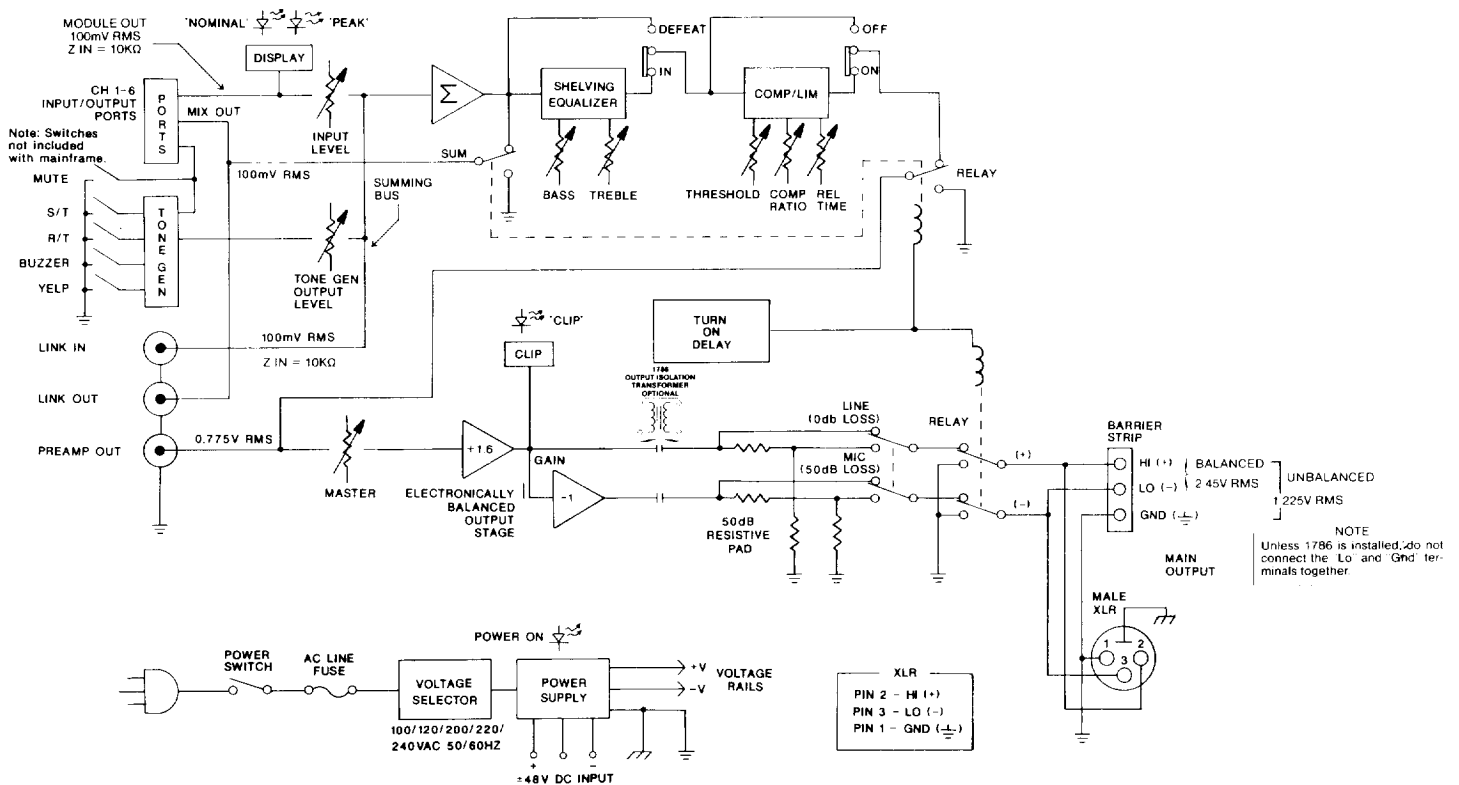

Figure 7. Block Diagram of Mixer/Preamplifier Mainframe

The signal coming from each input module, (like the 1781A/AT, or the 1780A/AT), is simultaneously routed to the front panel nominal/clip LED indicators and the input channel level control. The dual LED display is pre-fader and designed to monitor the output level from the corresponding input module. The nominal (green) LED indicator has approximately a 10 dB window over which it is illuminated. This makes it easy to properly adjust the gain for each module while optimizing the rest of the system in terms of performance and headroom.

The resulting signal at the wiper of each input channel level control is summed into a true virtual ground summing node. The summing amplifier has eight input channels (input channels 1 through 6, the tone generator, and the link input). The output of the summing amplifier drives the link output on the rear of the mainframe, and the E.Q. control and compressor/limiter sections which are in series with each other as shown in the diagram. The output of the compressor/limiter drives the preamplifier output (PREAMP OUT on the rear panel). This provides the input signal to the main line output stage.

The BASS and TREBLE E.Q. controls are ideally suited to make the sometimes necessary adjustments to the overall response of the mix. The low and high frequency shelving equalizers provide ± 12 dB of boost and cut with the peaks occurring at 100 Hz and 10 kHz, respectively.

The compressor/limiter section features a feed-forward topology which enables it to minimize level differences for a more nearly constant output level. The compression ratio can approach $\infty:1$ and the attack time is fixed at approximately 10 ms.

The output of the preamplifier furnishes the driving signal for the main output stage. Although the main output stage is an electronically balanced output circuit for increased drive capability and more headroom, an optional 1786 output transformer may be installed to provide complete isolation.

A signal overload circuit monitors the level at the main output. A front panel clipping indicator warns that signal levels are high enough to cause significant output clipping.

4.2 Main Output Connections

Output connections may be made to either the 3-terminal barrier strip or male XLR connector located on the rear of the mainframe.

4.2.1 The MIC/LINE Switch

The main output is normally a line level output. Sometimes, however, it may be necessary to route the output of the 1700C through a "snake" cable or other predominantly mic level, multi-conductor cable. A line level signal could induce noise and crosstalk into the adjacent microphone lines. To accommodate

this type of situation, the 1700C includes a 50 dB output pad. When the MIC/LINE switch is in the MIC position, the output level is reduced by 50 dB. In the LINE position, the pad is bypassed. Refer to Figure 8 for typical output connections.

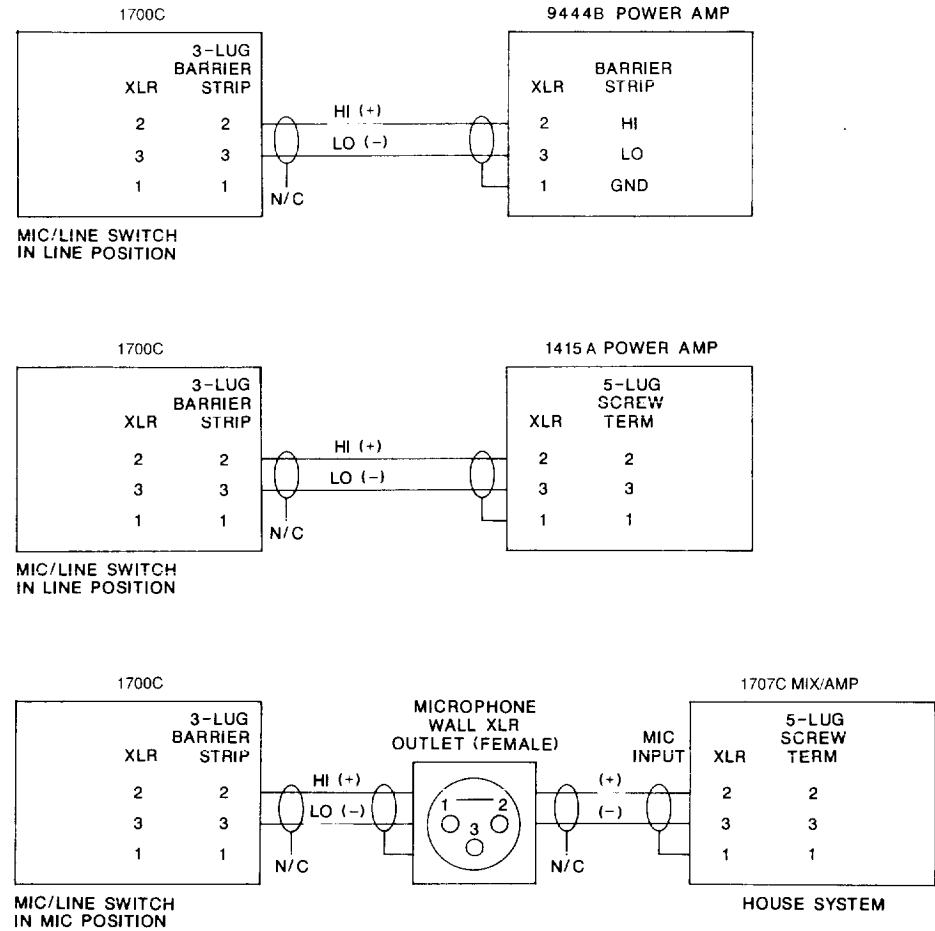

Figure 8. Typical Output Connections

4.3 Mute/Tone Generator Connections

The 7-lug screw terminal connector located on the rear of the mainframe provides access to the system mute and the tone generator. For connection details, refer to Figure 9.

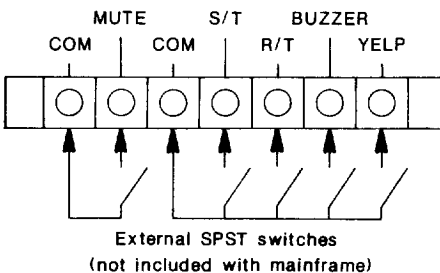

Figure 9. Mute/Tone Generator Switch Connections

A switch closure between the mute and common terminals will mute any input module configured in the slave mode. The remaining switches are used to select and sound either the single-tone chime (S/T), repeating-tone chime (R/T), buzzer, or yelp (siren). For the duration of a tone, the tone generator automatically mutes any slave input modules.

The tone generator's output level control has been conveniently located on the rear panel of the mainframe. Rotating the screwdriver-slotted control shaft clockwise will increase the output level of the tone generator.

4.3.1 Resistance Effects of Long Cable Runs on the Mute and Tone Generator Circuits

Table III shows the maximum allowable cable resistance (total resistance) that can be supported. Resistances greater than these values (resulting from excessively long cable runs or small gauge wire) may cause the mute or tone generator circuitry to fail to operate. Please make sure all cable resistances are less than the values shown in Table III.

Table III. Maximum Allowable Cable Resistances

Function	Resistance Ω
S/T Chime	13 k Ω
R/T Chime	15.8 k Ω
Buzzer	8 k Ω
Yelp	8 k Ω
Mute	8 k Ω

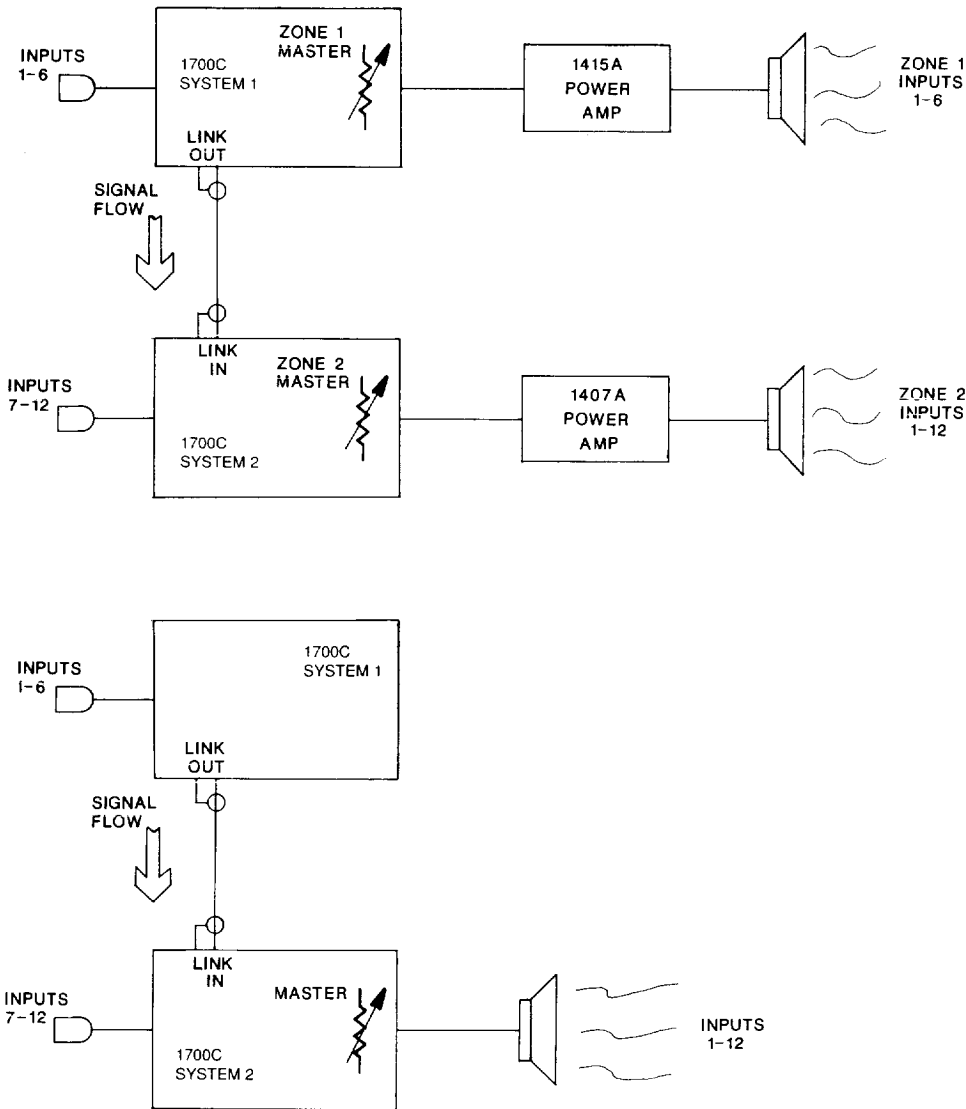

Figure 10. Typical Linking Connections

4.4 LINK IN/LINK OUT Connections

The LINK IN/LINK OUT phono connectors on the rear of the mainframe permit two or more systems to be dynamically "linked" together. The signal appearing at the LINK OUT connector is the summation of all input channels as mixed by the input level controls. LINK IN is a direct input to the system's mixing amplifier. In actuality, it is a seventh input channel.

One common application is to expand the number of microphone channels in an existing installation. To link two units together, connect LINK OUT of system 1 to LINK IN of system 2. System 2 will now control the mix of up to 12 input channels. Please refer to Figure 10 for typical linking connections.

NOTE

The LINK OUT signal is not affected by the compressor/limiter or E.Q. control circuits. Please refer to the block diagram shown in Figure 7.

4.5 PREAMP OUT Connections

The PREAMP OUT signal is a mix of all input channels as processed by the compressor/limiter and E.Q. control circuits. It is an unbalanced output capable of driving loads as low as 600 Ω s. The output is well suited to drive tape or cassette recorders. Figure 11 shows some typical connection schemes.

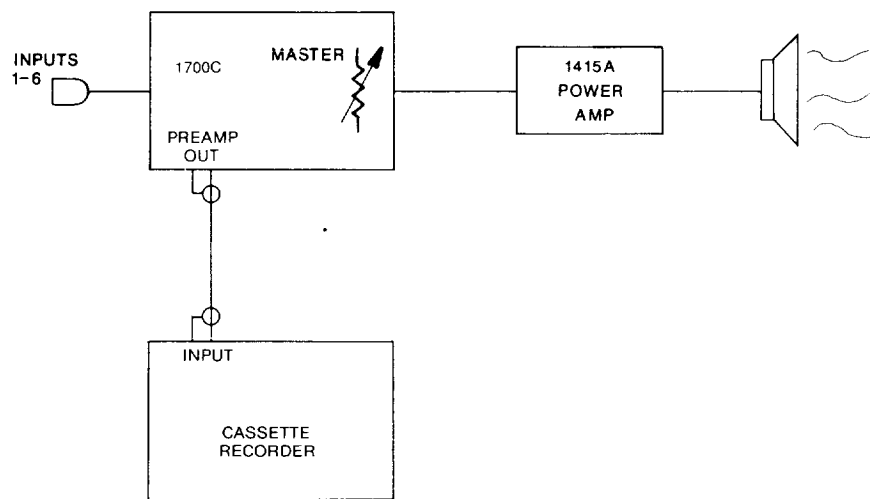

Figure 11. Typical PREAMP OUT Connections

4.6 Battery Input Connections

The system is operable from ± 48 VDC. Connect the battery backup system to the 3-terminal barrier strip located on the rear of the mainframe as shown in Figure 12.

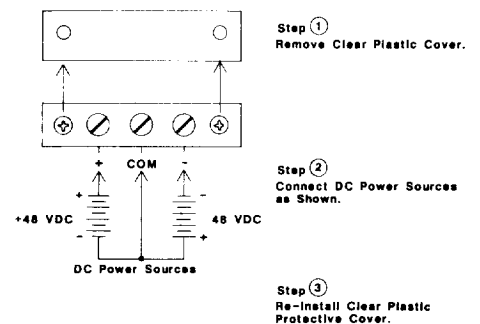
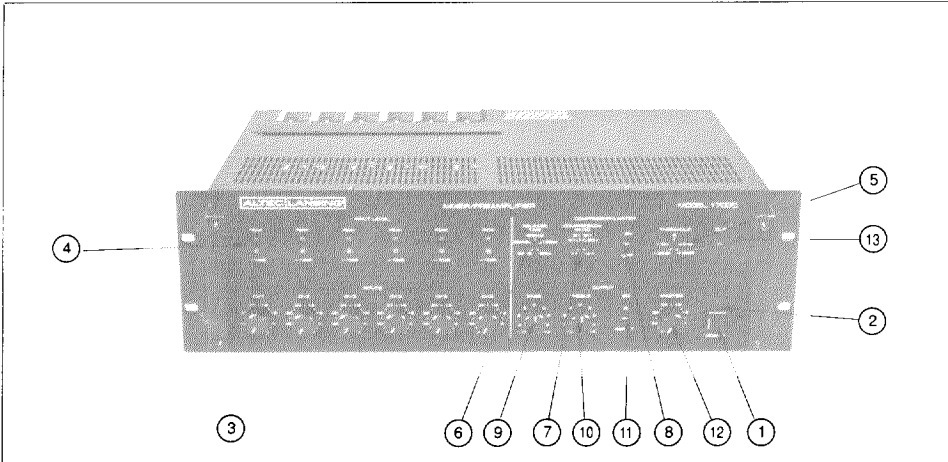

Figure 12. Battery Input Connections

FRONT/REAR-PANELS CONTROLS, SWITCHES, INDICATORS, AND CONNECTORS

Figure 13 below displays the front panel on the 1700C mixer/preamplifier with numbers that point out each control, indicator, and switch. You can find the corresponding number and name/description of each control, switch, or indicator in the text below Figure 13.

Figure 13. Front-Panel Control, Switches, and Indicators for the 1700C



Item	Name	Function/Description
1	POWER Switch	Applies primary power. Two-position push-push switch for on/off mode.
2	ON LED Indicator	Illuminates red display on POWER switch when you turn on power.
3	CH 1-6 Controls	INPUTS Continuously variable potentiometers graduated from ∞ to 0 dB. You can increase or decrease level for each corresponding input channel. Rotate clockwise to increase level and counterclockwise to decrease level.
4	Green/Red Dual LED Indicators	INPUT LEVEL Displays nominal (green) and peak (red) indication for each channel.
5	THRESHOLD Control	COMPRESSOR/LIMITER Continuously variable potentiometer. Determines the level at which limiting begins.
6	RELEASE TIME Control	Continuously variable potentiometer. Determines the time required for the system to return to normal after signal falls below threshold.
7	COMPRESSION RATIO Control	Continuously variable potentiometer. Determines the amount of limiting that will occur when the input signal level exceeds the threshold, as set by the THRESHOLD control.
8	ON/OFF Switch	Places compressor/limiter circuit in or out of the signal path.
9	BASS Control	OUTPUT Continuously variable potentiometer. Provides boost or cut in bass response. You can obtain normal or flat response at a zero setting. Rotate clockwise to boost response or counterclockwise to cut response.
10	TREBLE Control	Continuously variable potentiometer. Provides boost or cut in treble response. You can obtain normal or flat response at a zero setting. Rotate clockwise to boost response or counterclockwise to cut response.
11	EQ IN/DEFEAT Switch	Two-position switch. DEFEAT position disconnects BASS and TREBLE controls when appropriate for application, such as Acousta-Voicing. EQ IN connects the BASS and TREBLE controls.
12	MASTER Level Control	Continuously variable potentiometer graduated from ∞ to 0 dB. Use it to simultaneously increase or decrease all input channels. Rotate clockwise to increase level or counterclockwise to decrease level.
13	CLIP LED Indicator	Illuminates when an internal signal overload circuit detects high output signal levels that may cause output clipping.

5.0 INITIAL SETUP AND OPERATION OF THE 1700C MIXER/PREAMPLIFIER WITH INPUT AND OUTPUT MODULES INSTALLED

5.1 Initial Setup of an Input Module

1. Rotate the input module's gain control to the 12:00 o'clock (MID) position for planned microphone inputs or MIN (full counterclockwise) position for line level inputs. If the input type is unknown, rotate the gain control to the MIN position.
2. Verify the HF filter is in the FLAT position, (if applicable).
3. Verify the LF filter is in the FLAT position.

5.2 Initial Setup of an Output Module

Rotate the 1783's output level control (labeled "GAIN" on the rear panel) to the MIN position.

5.3 1700C Initial Setup

1. Rotate the MASTER output level control on the front of the mainframe to the " ∞ " position (fully counterclockwise).
2. Set the compressor/limiter ON / OFF switch to the OFF position.
3. Set the E.Q. control IN/DEFEAT switch to the DEFEAT position.
4. Set the MIC/LINE switch on the rear panel to the LINE position.

5.4 Operating the 1700C Mixer/Preamplifier System

1. Connect a source representative of the type of input signal to one of the input module positions (if any). Slowly rotate the gain control on the module until the green LED (-10 dB) on the front panel is fully illuminated. This represents the nominal level of optimum performance and headroom. On occasion, the red LED may briefly illuminate on signal peaks.

This is permissible as long as it does not flash more than 50% of the time. If it does, reduce the gain of the module by rotating the gain control counterclockwise or use an external pad.

NOTE

The LED display precedes the front panel input level control. As a result, it will always indicate nominal and peak levels regardless of the input channel level control setting. Please refer to the block diagram in Figure 7.

2. Once the gain is set for each input module channel, adjust the front panel input level controls to their 12:00 o'clock (MID) position. Slowly increase the MASTER level control on the front of the 1700C until a normal operating level is heard through the loudspeaker system and re-adjust the input channel level controls slightly for the desired mix or blend of signals.
3. The high and/or low cut filters on the input modules should be adjusted as needed for the desired response tailoring. The widest possible bandwidth is in the FLAT position. This is the best setting for music.

Figure 14 below displays the rear-panel on the 1700C mixer/preamplifier with numbers that point out each connector or control. You can find the corresponding number and name/description of each connector or control in the text below Figure 14.

Figure 14. Rear-Panel Control and Connectors for the 1700C

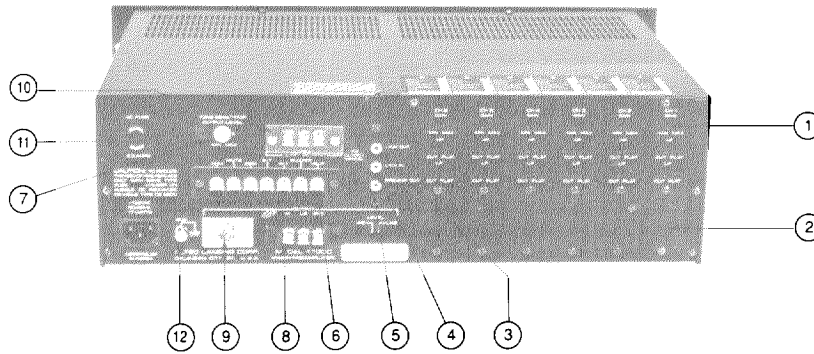

Item	Name	Function/Description
1	Access Holes	Permits access to the screwdriver adjustable controls on the modules.
2	Blank Cover Panel	Covers connector mounting holes. Protects against internal voltages when not using port and connector.
3	LINK OUT Connector	Combine two units together by connecting LINK OUT of system one to LINK IN of system two. This is an RCA-type phono connector.
4	LINK IN Connector	Provides a direct input to the preamplifier. This is an RCA-type phono connector (ref. 1 kHz, 100 mvrms).
5	PREAMP OUT Connector	Use to connect auxiliary equipment from unit's mixer. The PREAMP OUT connector precedes the front panel MASTER level control. This is an RCA-type phono connector.
6	Seven-Lug Screw Terminal Connector	Permits connection of external switches to operate the system's mute and tone generator circuits.
7	OUTPUT LEVEL Control	Increase the output level of the tone generator by rotating the screwdriver-slotted control shaft clockwise. To decrease the output level, rotate it counterclockwise.
8	Three-Terminal Barrier Strip Connector	Permits connection of unit's main output to auxiliary equipment inputs (amplifier, etc.).
9	Male XLR Connector	Different connector for same purpose as three terminal barrier strip.
10	Battery Input Connector	Use to power system from battery supply for auxiliary operation or standby switchover. Requires one \pm 48V DC battery power source, 0.5 amps maximum.
11	AC FUSE	Protects against excessive current drain from an alternating current source. Replace only with same fuse type and power rating.
12	GND	The ground terminal lets you connect auxiliary equipment to the mainframe.

However in speech-only channels, it is wise to limit the bandwidth. This helps reduce noise and the potential for system feedback.

- To use the E.Q. control section, move the slide switch to the IN position and adjust the bass and treble controls for the desired response tailoring. From center, rotate either control clockwise to boost or counterclockwise to cut.
- To use the compressor/limiter section, move the slide switch to the ON position. Rotate the release time control to its maximum position (full clockwise) and the compression ratio control to its Min. position (full Counterclockwise). Rotate the threshold control to its 12:00 o'clock (MID) position. Begin by increasing the compression ratio control (rotating the control clockwise towards Max. until the desired amount of compression or limiting is achieved. Since the amount of compression or limiting depends on the incoming signal level, it may be necessary to re-adjust the threshold control. Rotating the threshold control counterclockwise will lower the triggering threshold. Correspondingly, rotating the threshold control clockwise will raise the threshold (meaning that a higher level signal is required to trigger the compressor/limiter).

NOTE

A high compression ratio and a low threshold setting may decrease the system's apparent loudness since the peaks and possibly parts of the nominal signal may lie above the threshold. This can be corrected by raising the threshold level (rotating the threshold control clockwise).

- If a 1783 line output module is installed, adjust the output level control on the module for the desired output level. The higher the output level, the better the signal-to-noise ratio. However, too high a level reduces the available headroom and may cause premature clipping.

NOTE

REPAIR PERFORMED BY OTHER THAN AUTHORIZED WARRANTY STATIONS (DEALERS) OR QUALIFIED SERVICE PERSONNEL SHALL VOID THE WARRANTY PERIOD OF THIS UNIT. TO AVOID LOSS OF WARRANTY, SEE YOUR NEAREST ALTEC LANSING AUTHORIZED DEALER OR CALL ALTEC LANSING CUSTOMER SERVICE DIRECTLY AT (405) 324-5311, FAX (405) 324-8981, OR WRITE:
ALTEC LANSING CUSTOMER SERVICE/REPAIR
P.O. BOX 26105
OKLAHOMA CITY, OK 73126-0105
U.S.A.



1700C MIXER/PREAMPLIFIER

SERVICE INSTRUCTIONS

* * * CAUTION * * *

No user serviceable parts inside. Hazardous voltage and currents may be encountered within the chassis. The servicing information contained within this document is for use only by ALTEC LANSING Corp. authorized warranty stations and qualified service personnel. To avoid electric shock, DO NOT perform any servicing other than that contained in the Operating Instructions unless you are qualified to do so. Refer all servicing to qualified service personnel.

6.0 SERVICE INFORMATION

WARNING

Modifications to ALTEC LANSING products are not recommended. Such modifications shall be at the sole expense of the person(s) or company responsible, and any damage to persons to property resulting therefrom shall not be covered under warranty or otherwise.

6.1 Parts Ordering

To order replacement parts, note the component designator from the schematic (or printed circuit board), and the component's value. Then call (405) 324-5311, FAX (405) 324-8981, or write:

ALTEC LANSING Replacement Electronic Parts
P.O. Box 26105
Oklahoma City, OK 73126-0105 U.S.A.

6.2 Factory Service

Should factory service be required, ship the unit prepaid in a well packed carton to:

ALTEC LANSING Customer Service/Repair
10500 W. Reno
Oklahoma City, OK 73128 U.S.A.

Enclose a note describing the problem along with any other helpful information such as where used, how used, etc.

6.3 Technical Assistance

For applications assistance or other technical information, call (405) 324-5311, FAX (405) 324-8981, or write:

ALTEC LANSING Technical Assistance
P.O. Box 26105
Oklahoma City, OK 73126-0105 U.S.A.

DESIGNATOR	ALTEC PART NUMBER	DESCRIPTION
IC 001	17-01-124804	TA 7317 P
IC 002	17-01-037409I	KA 7818 (REG)
IC 003	17-01-037410I	KA 7918 (REG)
IC 201	17-01-037408I	GD 74HC 368
IC 301, 101, 501	17-01-027463	NJM 4558 DD
IC 605	17-01-037406I	SSM 2120
IC 602	17-01-037411I	TD 62507 P
IC 601	17-01-122833	NJM 5532 DD
IC 701	17-01-037412I	NJM 2068 DD
IC 603, 604	17-01-037407I	KIA 7359 P
Q901	48-03-124824	NPN KTC 2240 BL
Q001	48-03-037272I	NPN KTD 2058 Y
Q403	48-03-037676I	NPN 2SD 1302 R
Q004, 301,	48-03-037275I	PNP KTA 1015 Y
Q002, 003, 201-203, 401, 402, 404, 405, 902-904	48-03-026624	NPN 2SC 1815 Y
D1-11, 14, 17, 301, 401, 402, 601	48-01-027300	1N 4006
D18, 201, 202, 301, 401-402, 602, 603, 901, 902	48-01-122601	1N 4148
D12, 13	48-01-037400I	ZENER UZ-24BM
D203	48-01-037680I	ZENER UZ-5.6BM
Power ON LED	39-01-037681I	REC KLR 208 2x5 RED
D903	39-01-037402I	LED SLR-54GG R5 GRE ROHM
CLIP LED, D904	39-01-037403I	LED SLR-54UR R5 RED ROHM
RLY A, B	45-01-037394I	RELAY RY 24W-K DC 24V

DESIGNATOR	ALTEC PART NUMBER	DESCRIPTION
AC Power Switch	51-02-037683I	SLIDE SSJ622
SW1	51-02-037737I	SWITCH SLIDE SSP 322
F1, F2	51-04-037392I	NB 31.8mm 0.5A/250V UL/CSA
F3	51-04-037735I	NB 31.8mm 0.3A/250V UL/CSA
Accessory Fuse (International)	51-04-037736I	NB 31.8mm 0.15A/250V UL/CSA
SVR 601	47-06-037399I	SEMI CS 100KB 10/5
VR 901	47-06-037395I	Φ 16 K161 MOO-20KA
VR 501, 502	47-06-037396I	Φ 16 K161 MOO-100KB CC
VR 503	47-06-037686I	Φ 16 K161 MOO-50KB
VR 601	47-06-037397I	Φ 12 K121 LOO-10KA
VR 602	47-06-037398I	Φ 12 K121 LOO-10KRD
VR 603	47-06-037687I	Φ 12 K121 LOO-100KB CC
TONE VOLUME	47-06-037688I	Φ 16 10KAx1
R023	47-01-037201I	MO 10Ω 1W 5%
R020	47-01-102893	MO 100Ω 1W 5%
R001, 002	47-01-037343I	CE 100Ω 5W 5%
R008, 018, 019, 213	47-01-100647	MO 680Ω 1W 5%
R108, 109	47-01-037738I	CF 10Ω 1/5W 5%
R601, 602	47-01-037691I	CF 33Ω 1/5W 5%
R623, 113, 114	47-01-037692I	CF 47Ω 1/5W 5%

DESIGNATOR	ALTEC PART NUMBER	DESCRIPTION
R331, 332	47-01-037120I	CF 100Ω 1/5W 5%
R112	47-01-037342I	CF 180Ω 1/5W 5%
R617, 619	47-01-037694I	CF 200Ω 1/5W 1%
R906	47-01-037252I	CF 220Ω 1/5W 5%
R616	47-01-037695I	CF 1.00kΩ 1/5W 1%
R115, 404	47-01-037121I	CF 1kΩ 1/5W 5%
R606, 633	47-01-037371I	CF 1.2kΩ 1/5W 5%
R909	47-01-037739I	CF 2.7kΩ 1/5W 5%
R505, 506, 607	47-01-037696I	CF 2.2kΩ 1/5W 5%
R618	47-03-037697I	CF 3.24kΩ 1/5W 1%
R008, 009, 101, 910, 911	47-01-037254I	CF 3.3kΩ 1/5W 5%
R104-107, 402, 905	47-01-037166I	CF 4.7kΩ 1/5W 5%
R103, 305	47-01-037255I	CF 5.6kΩ 1/5W 5%
R627, 628, 308	47-01-037168I	CF 7.5kΩ 1/5W 5%
Note: If Q302 is a KTC1815(Y), then R308 is:	47-01-037125I	CF 15kΩ 1/5W 5%
R319, 504	47-01-037256I	CF 8.2kΩ 1/5W 5%
R004, 007, 208, 401, 411, 608- 611, 630, 631, 904	47-01-037169I	CF 10kΩ 1/5W 5%
R502, 702, 706, 912	47-01-037124I	CF 12kΩ 1/5W 5%
R621	47-03-037700I	CF 15.0kΩ 1/5W 1%

DESIGNATOR	ALTEC PART NUMBER	DESCRIPTION
R011, 212, 614, 903	47-01-037125I	CF 15kΩ 1/5W 5%
R015, 501, 503	47-01-037171I	CF 18kΩ 1/5W 5%
R013, 102	47-01-037258I	CF 47kΩ 1/5W 5%
R003, 006, 010, 403,	47-01-037257I	CF 22kΩ 1/5W 5%
R330, 005, 110, 111, 622	47-01-037357I	CF 27kΩ 1/5W 5%
R620, 626	47-03-037701I	CF 30.1kΩ 1/5W 1%
R016, 204, 320, 907, 908	47-01-037174I	CF 33kΩ 1/5W 5%
R615	47-03-037703I	CF 39.2kΩ 1/5W 1%
R017, 507, 629, 632, 901, 707, 708, 701	47-01-037175I	CF 56kΩ 1/5W 5%
R605	47-01-037369I	CF 75KΩ 1/5W 5%
R704, 705	47-03-037704I	CF 93.1kΩ 1/5W 1%
R012, 304, 307, 310, 311, 315, 316, 318	47-01-037126I	CF 100kΩ 1/5W 5%
R624	47-03-037706I	CF 162kΩ 1/5W 1%
R014, 203, 205- 207, 209- 211, 301, 306, 410	47-01-037261I	CF 220kΩ 1/5W 5%
R612	47-03-037707I	CF 267kΩ 1/5W 1%
R625	47-03-037708I	CF 316kΩ 1/5W 1%
R309	47-01-037262I	CF 330kΩ 1/5W 5%
R613	47-03-037710I	CF 330kΩ 1/5W 1%
R604	47-01-037128I	CF 470kΩ 1/5W 5%

DESIGNATOR	ALTEC PART NUMBER	DESCRIPTION
R312	47-01-037364I	CF 560k Ω 1/5W 5%
R313	47-01-037365I	CF 680k Ω 1/5W 5%
R201, 202, 215, 317	47-01-037363I	CF 1.5m Ω 1/5W 5%
R314, 902	47-01-037368I	CF 2.2m Ω 1/5W 5%
R302, 303, 603	47-01-037415I	CF 3.3m Ω 1/5W 5%
C009	15-01-037219I	AF RSA 0.47 μ F 50V
CO07, 202, 203, 311, 313, 605, 901, 902	15-01-124507	AF RSA 1 μ F 50V
C306	15-01-037711I	AF RSA 3.3 μ F 50V
C609	15-01-037712I	AF RSA 4.7 μ F 25V
C607	15-01-037221I	AF RSA 4.7 μ F 50V
C101, 111, 112, 606, 615	15-01-122935	AF RSA 10 μ F 35V
C207	15-01-037222I	AF RSA 10 μ F 50V
C204	15-01-037715I	AF RSA 22 μ F 16V
CO08	15-01-037143I	AF RSA 22 μ F 25V
C401, 501, 507, 612, 701, 704, 705, 903	15-01-037380I	AF RSA 33 μ F 16V
C208	15-01-037716I	AF RSA 47 μ F 16V
C300, 316, 012	15-01-027327	AF RSA 47 μ F 25V
C003-005	15-01-037144I	AF RSA 47 μ F 63V
C012	15-01-037717I	AF NP 47 μ F 25V
C604, 614	15-01-037432I	AF RSA 100 μ F 16V

DESIGNATOR	ALTEC PART NUMBER	DESCRIPTION
C104, 105, 601, 602, Series Output capacitors (2)	15-01-037225I	AF RSA 100 μ F 25V
C000-002	15-01-037740I	AF RSA 1000 μ F 35V
C309, 310	15-06-037190I	M 0.0015 μ F 100V J
C504	15-06-037139I	M 0.0018 μ F 100V J
C206	15-06-037140I	M 0.0033 μ F 100V J
C308	15-06-037194I	M 0.0056 μ F 100V J
C502, 503	15-06-037285I	M 0.018 μ F 100V J
C312	15-06-037719I	M 0.033 μ F 100V J
C305,	15-02-100109	M 0.1 μ F 100V J
C303	15-06-037432I	M 0.22 μ F 100V J
C702	15-02-100014	C 15pF 50V J
C102, 103, 505, 603, 613	15-02-107455	C 47pF 50V J
C611	15-02-037205I	C 100pF 50V J
C506, 703	15-02-107470	C 220pF 50V J
C299, 608, 616	15-02-100304	C 0.001 μ F 50V Z
C201, 205, 301, 302, 402, 404, 298, 403	15-02-037179I	C 0.01 μ F 50V Z
C610	15-02-037164I	C 0.047 μ F 50V Z
C315	15-02-037165I	C 0.1 μ F 50V Z
C1	15-02-037724I	C 0.0047 μ F 400VAC
PT	56-08-037393I	POWER TRANSFORMER

SCHEMATIC

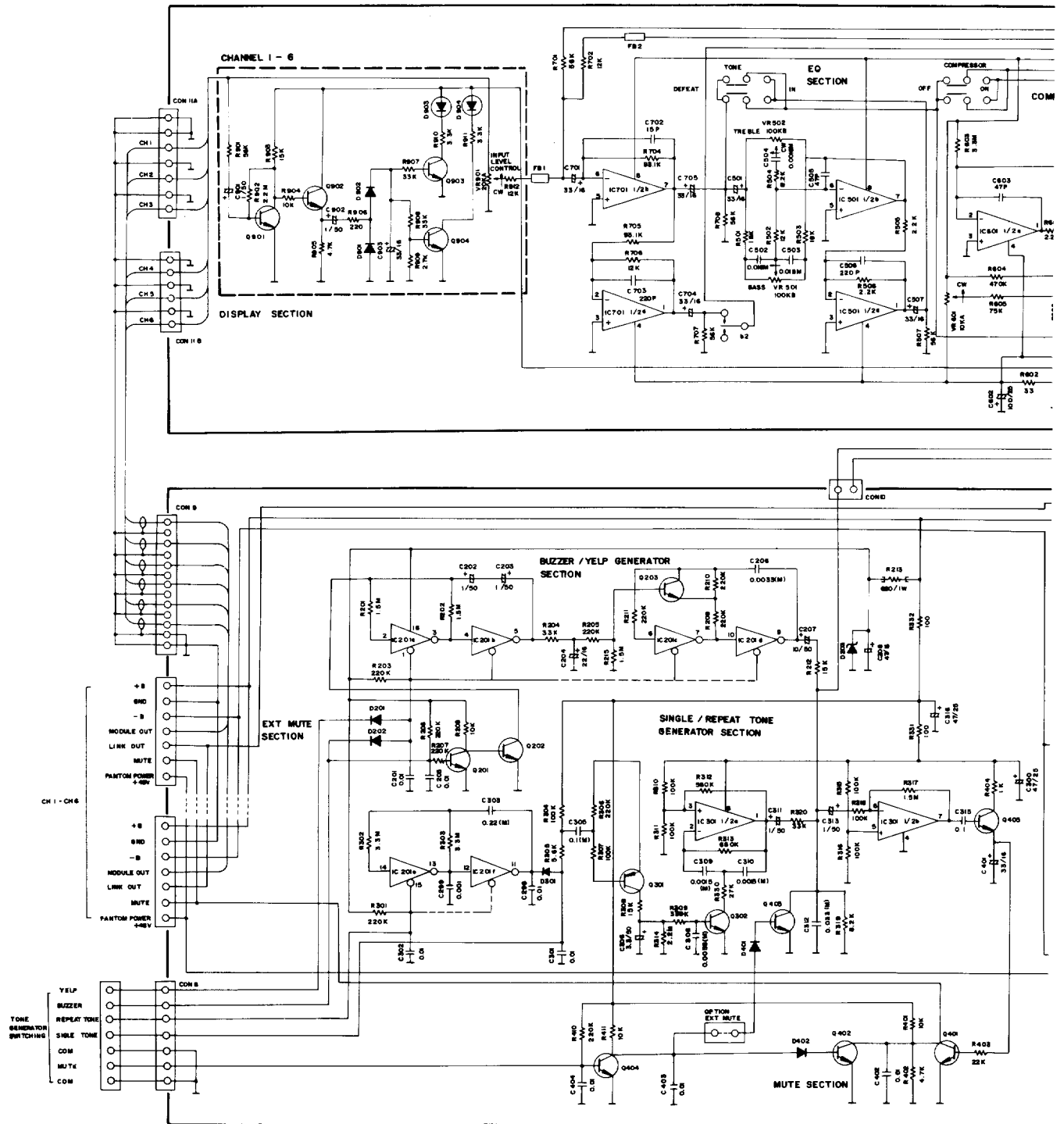

SERVICE INFORMATION

- RESISTANCE VALUES ARE INDICATED IN OHMS UNLESS OTHERWISE SPECIFIED.
(R = 1,000, M = 1,000,000)
- CAPACITANCE VALUES ARE SHOWN IN MICROFARADS UNLESS OTHERWISE NOTED
(P = PICO - MICROFARADS)
- ALL VOLTAGES ARE REFERRED TO GROUND UNLESS OTHERWISE SPECIFIED.
DC - NO SIGNAL EXCEPT WHERE INDICATED.
AC - RMS
- PRECAUTIONS
 - ALL COMPONENTS MARKED MUST BE REPLACED ONLY WITH ORIGINAL TYPE SPECIFIED BY THE MANUFACTURER, AND INSTALLED AS THE ORIGINAL, SPACERS POSITIONED AWAY FROM ADJACENT COMPONENTS WHERE APPLICABLE.
 - ALL SOLDERING MUST BE DONE IN A PROFESSIONAL MANNER USING SOLDER WITH ROHS CORE ONLY.
 - ALL COVERS, SHIELD AND INSULATING SPACERS MUST BE REPLACED BEFORE RETURNING APPLIANCE TO CUSTOMER.
 - A DAMAGED POWER SUPPLY CORD MUST BE REPLACED BEFORE RETURNING TO CUSTOMER.
 - DIELECTRIC TEST CONSISTING OF 500V AC 60Hz IS TO BE APPLIED BETWEEN BOTH BLADES OF THE POWER SUPPLY CORD ATTACHMENT PLUS AND THE EXPOSED CONDUCTIVE SURFACE OF THE APPLIANCE FOR A PERIOD OF NOT LESS THAN ONE SECOND BEFORE RETURNING APPLIANCE TO CUSTOMER.
 - THE -3-WATT- MARKED RESISTORS ARE MOUNTED THE P.C.B. ON SLEEVES

- NOTE :
- Q403 : RTD 1502
 - Q301, Q004 : A1015
 - Q002, Q004, 201 - 206, 401, 402, 404, 405, 502, 503 - 504 : C 1815
 - Q300 : D3055
 - Q302 : C2350
 - D1 - 11, 14, 17 : 1N 4008
 - D18, 20, 202, 401, 402, 501, 502, 503, 504 : 1N 4148
 - D16, 15 : 2D 248M
 - S 203 : 2D5 48M
 - IC 101, 301, 501 : 4558
 - IC 001 : TA 751TP
 - IC 005, 804 : 6039 IC355
 - IC 205 : TA 738P
 - IC 206 : 58M 2120
 - IC 207 : TD 82807P
 - IC 601 : 5932
 - IC 701 : 2088
 - IC 002 : 7818 (REG)
 - IC 003 : 7806 (REG)

DIAGRAM

NOTE:
 If Q302 is a KTC 1815(Y)
 R308 is a 15kΩ 1/5W 5%
 If Q302 is a KTC 3198(Y)
 R308 is a 7.5kΩ 1/5W 5%

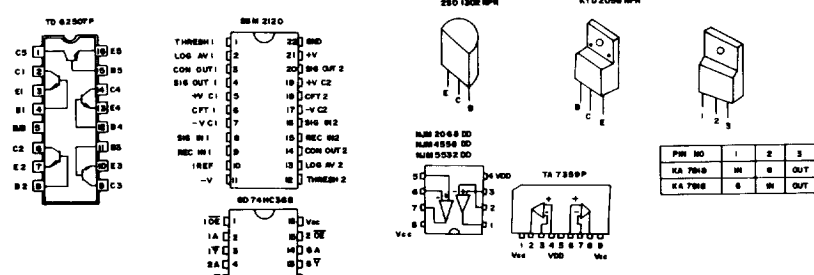
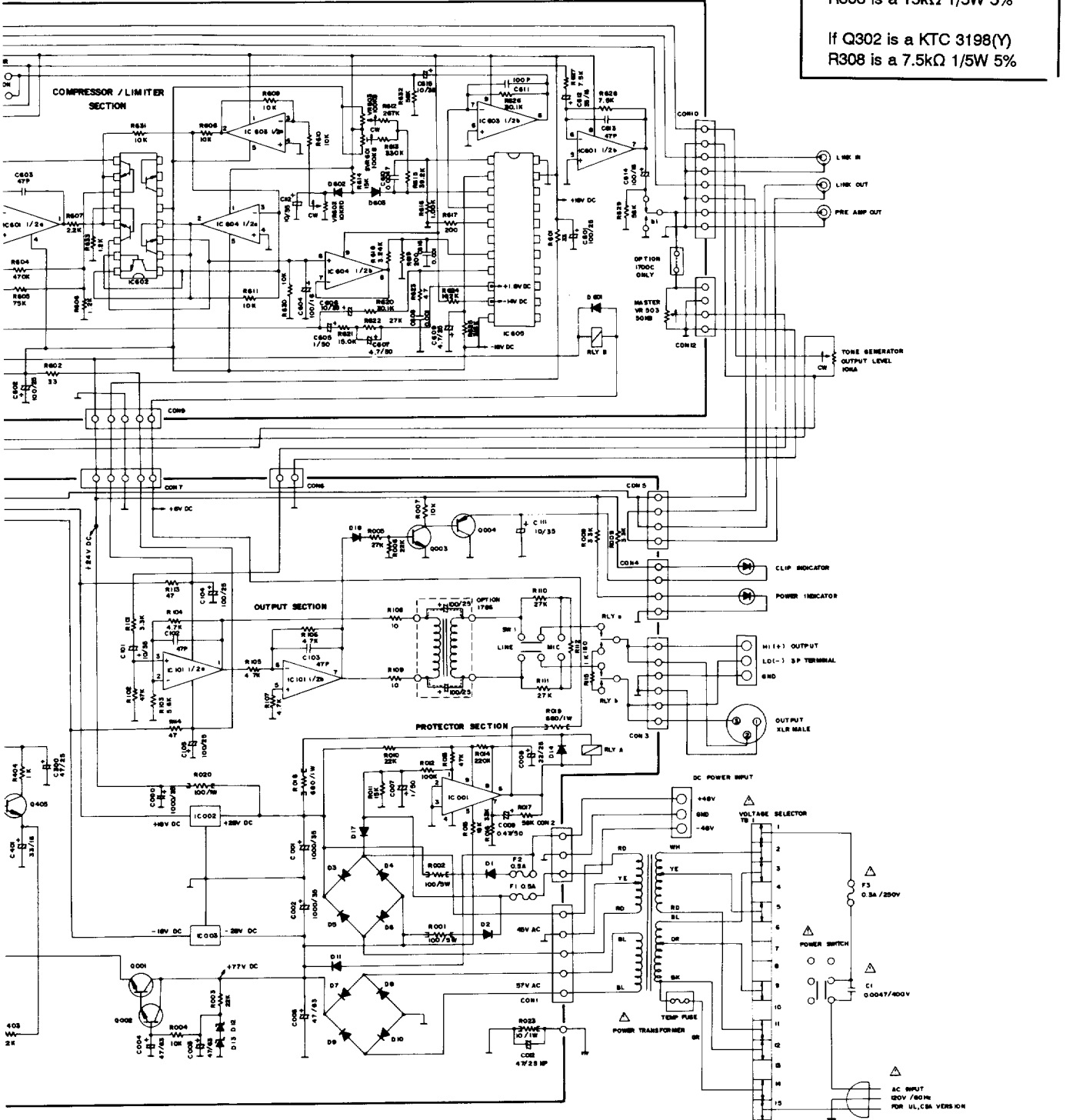

PRIMARY LINE VOLTAGE	WHITE	YELLOW	RED	BLUE	ORANGE
100V	5	2	11	9	3
120V	2	5	11	3	9
200V	5	2	7	10	6
220V	3	2	7	8	10
240V	2	5	7	8	10

EQUIPMENT	MIXER AMPLIFIER	MODEL	1700 C
DRAWN	CHECKED	APPROVED	DATE
			90
			7 18
			9880193