

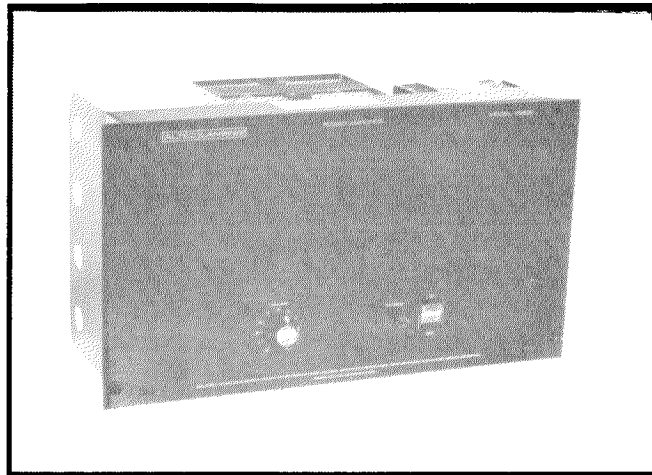

# 1590E Power Amplifier



## KEY FEATURES

- ★ DC Voltage Backup Ensures Uninterrupted Operation
- ★ Switchable High-Pass Filter

## DESCRIPTION

The Altec Lansing **1590E** Power Amplifier is designed for applications where uninterrupted operation is a priority. The **1590E** provides 200 watts of power at less than 1% total harmonic distortion (THD) from 50 Hz to 12 kHz, and has a frequency response of -1 dB from 20 Hz to 20 kHz at one watt output. Output transformer taps provide connections for 70.7, 100, 140 and 200 volt line distribution systems.

The **1590E** features silicon solid-state circuitry, a switchable high-pass filter for use in speech systems, input connections for high impedance devices and for 150/600 ohm or 15,000 ohm balanced inputs, fail-safe protection for output transistors, and a hinged front panel for rapid access to the chassis interior.

The **1590E** is capable of operation from a negative grounded 24/28 V DC source. The **1590E** is UL listed for use in commercial audio systems and fire protective signaling systems.

Designed for rack-mounted use, the **1590E** occupies six units of vertical space, 10.5 inches (26.7 cm).

## SPECIFICATIONS

<b>Gain:</b>	67 dB.
<b>Input Sensitivity:</b>	0.8 Vrms for rated output.
<b>Power Output:</b>	200 watts at less than 1% THD from 50 Hz to 12 kHz.
<b>Frequency Response:</b>	±1 dB, 20 Hz to 20 kHz at 1 watt output. ±1 dB, 50 Hz to 12 kHz at rated output.
<b>Input Impedance:</b>	15 kohms. 15 kohms balanced with 15335A Line Transformer. 150/600 ohms balanced with 15095A Line Transformer.
<b>Load Impedance:</b>	25, 50, 100, and 200 ohms.
<b>Load Voltage:</b>	70.7, 100, 140 and 200 volts.
<b>Output Impedance:</b>	Less than 25% of nominal load impedance.
<b>Noise Level:</b>	Output noise 85 dB below rated output.
<b>Operating Temperature Range:</b>	Up to 55°C (131°F).
<b>Controls:</b>	1 VOLUME control, continuously variable. 1 power OFF-ON switch. 1 high-pass filter switch.
<b>Power Required:</b>	100/120/220/240 AC, 50/60 Hz, 25 W at zero signal, 420 W at 200 W output. -or- 24/28 V DC (battery (-) is ground), 0.2 A at zero signal, 14 A at 200 W output.
<b>Special Features:</b>	Automatic transfer from AC to DC power in the event of AC power failure. Dissipation sensing circuit for protection of output transistors. High-pass filters.

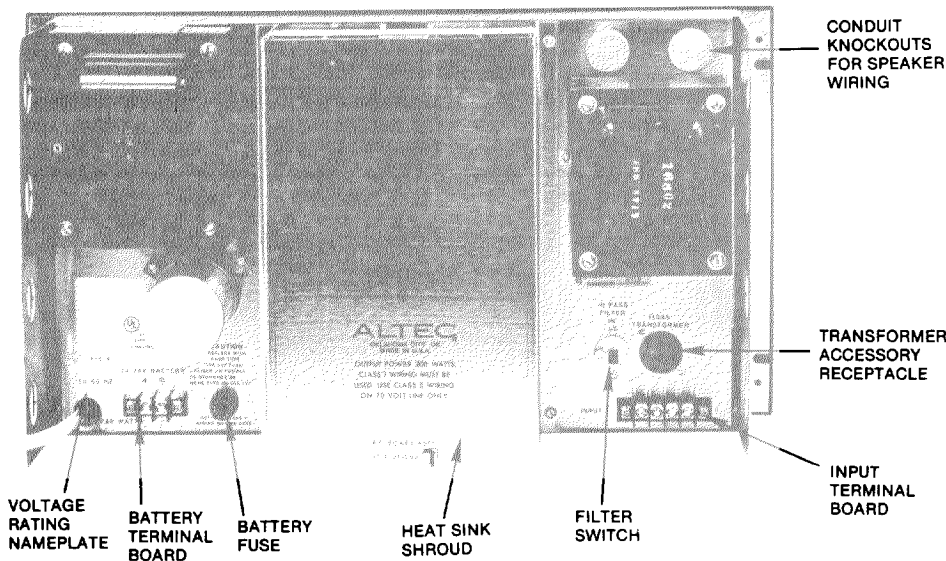

Figure 2. Rear View of 1590 Power Amplifier

Terminal Block TB8/TB9 Connections			
Transformer T1			
Wire Color	100V	120V	240V
Brown	TB9-4	TB8-4	TB8-4
White	TB8-4	TB9-4	TB9-2
Black	TB9-7	TB9-7	TB9-5
White-Brown	TB9-1	TB8-3	TB9-4
White-Black	TB9-8	TB9-8	TB9-8
Permanent AC Power Connections*			
Pilot Light S2-4	TB9-6		
AC Cord (black)	TB8-9		
AC Cord (white)	TB9-9		
Switch SW2-3	TB8-5		
Fuse F1-2	TB8-8		
Capacitor C7	TB9-10		
Capacitor C6	TB8-10		

\*Do not make any wiring changes of these wire connections when altering the amplifier for different primary power operating voltage.

Figure 3. Primary Power Conversion Chart for 100V, 120V, and 240V 50/60 Hz Operation

5. When 1590 is strapped for 200V or 240V line power, replace front panel fuse (F1) with 2A, 250V, slo-blo type fuse.

6. Close front panel and secure with four screws previously removed.

**Battery Connections**

If desired, the 1590 may be connected to an external 24/28 volt battery with minus (-) as ground. Terminals for the dc power connections are on TB4 (see Figure 2). If ac power fails, transfer to dc power is instantaneous, automatic and silent. The battery power supply is not operated by the primary power ON-OFF switch on the front panel. If switching of battery power is desired, an external relay or switch should be provided by the user.

**Input Connections**

Input connections may be either direct or transformer-isolated at the INPUT terminal board (TB1) (see Figure 2). Direct coupling is accomplished by connecting the input leads (shielded conductor recommended) to terminals 1 and 2. Terminal 2 is ground (see Figure 4).

For transformer-isolated input, a plug-in 15095A or 15335A Line Transformer must be plugged into receptacle J1 (see Figure 2).

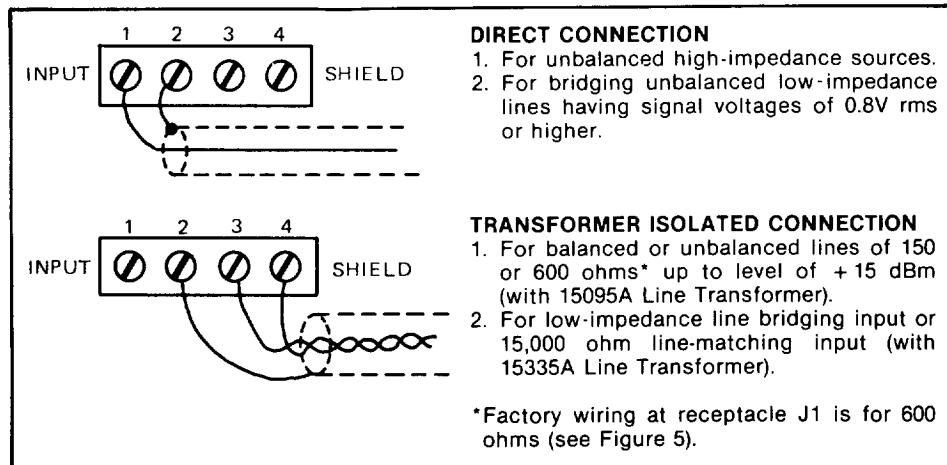

Figure 4. Input Connections

The input leads are connected to terminals 3 and 4 of the INPUT terminal board (see Figure 4).

When shipped from the factory, pins 3 and 4 of J1 are strapped together to provide a 600-ohm input. A 150-ohm input may be obtained by removing the strap from pins 3 and 4 and then strapping pin 1 to 4, and strapping pin 3 to 6 (see Figure 5).

Both the direct and transformer isolated inputs may be used simultaneously if isolation resistors are installed in either or both input lines, to prevent one input source from short circuiting to the other.

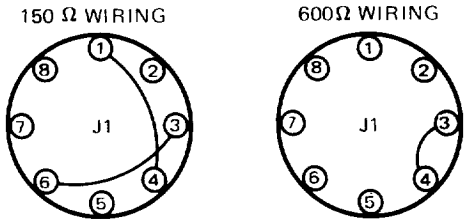

Figure 5. Wiring of Transformer Accessory Receptacle for Input Impedance of 150 or 600 Ohms. Factory Wiring is for 600 Ohms

**Output Connections**

Output transformer taps provide connections for 25V (140 watts), 30V, 70.7V, 100V, 140V and 200V distribution systems. Class I wiring must be used for 100V, 140V and 200V systems. Class II wiring may be used only for the 30V and 70V systems. Connections are made at terminal board TB2 located within the chassis (see Figure 6). Wiring from the speaker system feeds through the chassis to TB2; 1/2" conduit knockouts in the chassis provide access to output terminals of TB2 and permit termination as required for Class I wiring (see Figure 2).

Recommended wire size for 200V operation is 18 gauge (solid or stranded), for which power loss is 1/2 dB per 1900 feet of paired wire. When rigid conduit is not used clamp-type cable connectors must be installed in the conduit knockouts to secure the cable and provide strain relief.

**NOTE**  
Typical clamp-type cable connectors are the Appleton CG-1850 (for Class I flexible cord such as type SV or SVT), and the Appleton CG-1250 (for Class II audio cable such as Alpha Wire Corp. No. 1897 [stranded] or No. 1797 [solid]).

After speaker distribution wires are passed to the site of TB2, quick-connect terminal clips (T&B type RA257) must be installed. Be sure that output wiring between knockouts and TB2 does not exceed 9 inches in length. Strip 1/4" insulation from the wire ends and install the terminal clips. Twist stranded wire to assure that all strands properly enter the sleeve of the terminal clip. Use an appropriate crimping tool (such as M. Klein & Sons #1002) to crimp the terminal clips to the wire ends.

Connect terminal clips to the terminals of TB2 which have the desired impedance. If total speaker system impedance falls between two rated output values of the 1590,

### OPERATING INSTRUCTIONS

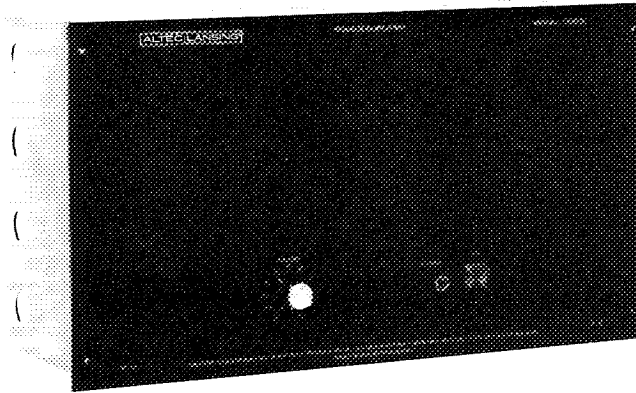

### OPERATION

#### Controls and Indicators

A VOLUME control and a primary power ON-OFF switch are located on the front panel. The power switch lights when power is turned on.

#### High-Pass Filter

A two-section high-pass filter is provided to protect driver loudspeakers from excessive low-frequency power demands. Filter use is indicated when high power output from the amplifier is applied to driver loudspeakers not equipped with protective crossover networks. The 3 dB frequency of the high-pass filter is 300 Hz.

A FILTER IN-OUT switch is located on the rear of the chassis (see Figure 1). The switch is placed in the OUT position when the 1590 is shipped from the factory. An adjustable lock plate, secured by a single screw, is used to lock the filter switch in either the IN or OUT position.

### INSTALLATION

#### Rack Mounting

The 1590 requires a vertical space of 10½' for installation in a standard 19-inch equip-

ment rack. Remove four screws securing the front panel. Open and lower the panel. Install the 1590 in the equipment rack with appropriate four screws supplied. Close and secure the front panel, using the four screws previously removed.

#### Ventilation

The 1590 generates moderate heat during normal use. Although the amount of heat is relatively low, the amplifier must be ventilated to prevent an excessive temperature rise. Air flow must not be impeded above or below the heat sink at the rear of the chassis. The 1590 should not be placed too close to other heat-generating equipment or in areas where ambient temperature exceeds 55°C (131°F).

If the 1590 is mounted in an equipment rack or cabinet with other heat-producing equipment mounted above and/or below, space must be provided between the units to prevent excessive temperature rise.

When several amplifiers or other heat-producing units are installed in a single rack or cabinet, acceptable air temperature may be in doubt. To determine temperature conditions, operate the system until temperature stabilizes, then measure air temperature with a bulb-type thermometer held at the bottom of the uppermost amplifier. Do not

allow the thermometer bulb to touch metal, because the metal may be hotter than the ambient air. If air temperature exceeds 55°C (131°F), the equipment should be spaced farther apart or a blower should be installed to ventilate the cabinet.

Adequate ventilation of the 1590 will enhance optimum function throughout the life of the amplifier, and prevent degradation of failure of output transistors, etc., due to prolonged operation at excessive temperatures.

#### 120 Volt, 50/60 Hz Power Connections

Equipment supplied for domestic use is provided with the power transformer primary strapped for 120 volts. The power input nameplate, on the rear of the chassis adjacent to the power cord, is mounted to show the appropriate side specifying the connections (see Figure 2). Verify that line voltage is in accordance with the voltage rating *before* connecting the 1590 to line power.

#### 100V, 200V, 240V 50/60 Hz Power Connections

Export equipment requires restrapping of the power transformer primary for voltages other than 120V, 50/60 Hz. Specified voltage rating is located on the chassis, adjacent to the power cord. See Figure 2. Verify that line voltage is in accordance with the specified voltage rating before connecting the 1590 to line power.

#### Conversion of Primary Power Operating Voltage

The Model 1590 Power Amplifier may be wired for operation at 100V, 120V, and 240V, 50/60 Hz. To change operational voltage rating of the amplifier, refer to the conversion chart of Figure 3 and proceed as follows:

1. Remove four screws securing front panel; open and lower panel.
2. Locate terminal block TB8/TB9 within the chassis; see Figure 6.
3. Referring to Figure 3, disconnect leads of transformer T1 from terminal block TB8/TB9. Pull each wire firmly to disengage push-on terminal connector. Reconnect leads in accordance with terminal designations that correspond to the desired operating voltage.

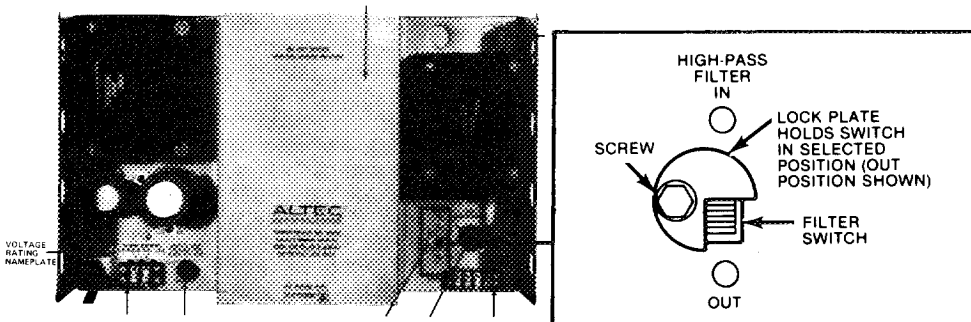

Figure 1. High-Pass Filter Switch

*Specifications and components subject to change without notice. Overall performance will be maintained or improved.*

## Specifications (continued)

<b>Design and Performance Approvals:</b>	Underwriters Laboratories listing 209j for Commercial Audio Systems, File E8783(N). Underwriters Laboratories listing 89MO for Fire Protective Signaling Systems, File S2925(N).	<b>Weight:</b>	41.0 lbs (18.6 kgs).
<b>Dimensions:</b>		<b>Color:</b>	Black.
Height:	10.5 inches (26.7 cm).	<b>Optional Accessories:</b>	<b>15095A</b> Line Transformer. <b>15335A</b> Bridging and Matching Transformer.
Width:	19.0 inches (48.3 cm).		
Depth:	8.3 inches (21.0 cm).		

### 1590E Back Panel

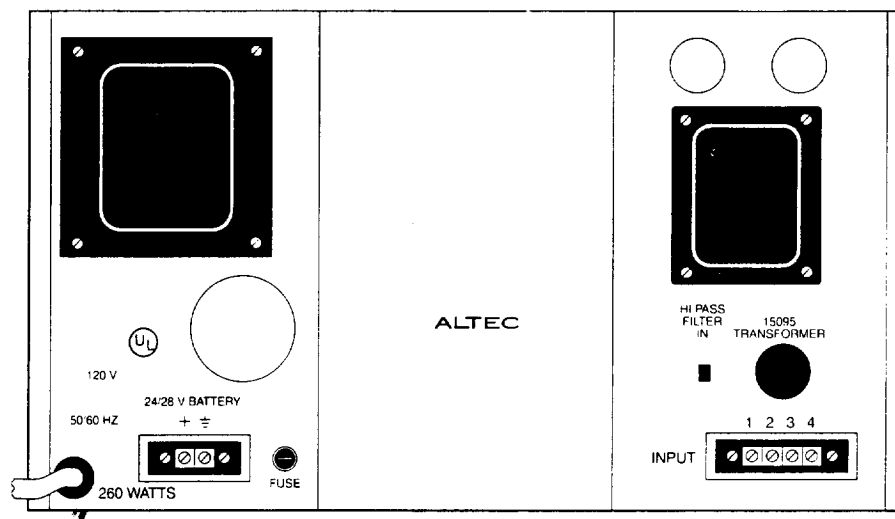

## ARCHITECT'S AND ENGINEER'S SPECIFICATIONS

The power amplifier shall be capable of operating from a 100, 120, 220, 240 V AC line or from a 24/28 V DC battery. The power supply shall automatically transfer the power to DC operation if AC power fails. An octal socket shall be provided on the rear panel for installation of an accessory line transformer. The front panel shall be hinged to permit access to the chassis interior without removing the amplifier from the equipment rack.

The power amplifier shall meet the following performance criteria: Gain, 67 dB. Input sensitivity, 0.8 Vrms for rated output. Power output, 200 watts at less than 1% THD from 50 Hz to 12 kHz. Frequency response,  $\pm 1$  dB from 20 Hz to 20 kHz at 1 watt output, and  $\pm 1$  dB 50 Hz to 12 kHz

at rated output. Input impedance, 15,000 ohms. Load impedance, 25, 50, 100 and 200 ohms. Load voltage, 70.7, 100, 140 and 200 volts. Output impedance, less than 25% of nominal load impedance. Noise level, output noise 85 dB below rated output. Operating temperature range, up to 55°C (131°F) ambient. Dimensions, 10.5 inches (26.7 cm) high by 19.0 inches (48.3 cm) wide by 8.3 inches (21.0 cm) deep. Weight, 41.0 lbs (18.6 kgs). The unit shall be black in color.

The power amplifier shall be Underwriters Laboratories listed for use in commercial audio systems and fire protection signaling systems.

The power amplifier shall be the ALTEC Model 1590E.



a MARK IV company

P.O. BOX 26105 • OKLAHOMA CITY, OK 73126-0105 • U.S.A.

Phone: 405/324-5311 or FAX: 405/324-8981

© 1994 ALTEC LANSING CORPORATION

Table I. Connections and Strapping Requirements of TB2 for Rated Outputs to Speaker Systems

Output Voltage to Speaker System	Impedance of Speaker System	Terminals of TB2 of 1590C	
		Speaker Connections	Strapping Requirements
25V (140W)	4.5 ohms	5 & 7	4 to 5; 6 to 7
30V (200W)	4.5 ohms	5 & 7	4 to 5; 6 to 7
70V (200W)	25 ohms	2 & 7	2 to 3; 6 to 7
100V (200W)	50 ohms	2 & 5	2 to 3; 4 to 5
140V (200W)	100 ohms	2 & 7	3 to 6
200V (200W)	200 ohms	2 & 5	3 to 4

NOTE: If connections are changed to accommodate a speaker distribution system of different impedance, be sure no straps are left on TB2 other than those required.

use the terminals of TB2 which designate the lower value. In addition, complete necessary strapping of TB2 terminals, as listed in Table I, to obtain proper voltage from the secondary of the transformer. If stray electrostatic radiation causes interference, strap terminal 2 (common) to terminal 1 (ground). Be sure all terminal clips are fully inserted over the male tabs of TB2.

### Speaker Power Distribution

The high-voltage output distribution system permits connections to a large number of speakers, each speaker to operate at a particular level. Each speaker in the system is equipped with a transformer having a number of terminals rated in terms of power. Select the tap which designates the power desired for each particular speaker. The total power for all speakers combined should be equal to, or less than the rated power of the 1590 (200 watts).

#### NOTE

For listing of loudspeaker transformers, refer to ALTEC Line Transformer Brochure.

### SERVICE INSTRUCTIONS

If a malfunction occurs, service should be performed by an ALTEC Qualified Service Representative. For factory service, ship the 1590 prepaid to:

ALTEC Customer Service/Repair  
10500 West Reno  
Oklahoma City, OK 73128

For additional information or technical assistance, call Altec's repair department at (405) 324-5311 or Telex 160-369.

#### CAUTION

Hazardous voltage may be encountered within the chassis. No user serviceable components inside. Refer to qualified service personnel.

### Access

Remove four screws securing the front panel, then open and lower hinged panel for access to chassis interior.

### Output Adjustment

Potentiometer R116 on the circuit board is factory adjusted for minimum distortion at 200 watts output at 1000 Hz. Should it become necessary to replace one or more of transistors Q3 through Q8, readjustment of R116 may be required. If a distortion analyzer is available, adjust R116 for minimum distortion of the output at 200 watts, 1000 Hz. Alternatively, use an oscilloscope and adjust R116 for equal top and bottom clipping of the waveform, with the amplifier driven just to the clipping point at 1000 Hz.

### Output 'Q' Balance Adjustment

Output 'Q' Balance controls R135 and R136 on the circuit board are factory adjusted to balance the bias current of output transistors Q1 through Q8. Inadequate adjustment of these controls may result in distortion or excessive current drain from one or more output transistors. If adjustment is indicated (such as replacement of one or more output transistors), use the following recommended procedure:

1. Turn VOLUME control fully counterclockwise to (0).
2. Remove four screws securing front panel, then lower panel for access to chassis interior.
3. Turn output 'Q' balance controls R135 and R136 fully counterclockwise.
4. Turn on power and allow a 5-minute warmup period for thermal stabilization.
5. Locate wire attached to terminal 1 of output transformer T2 (see schematic diagram). Connect a clamp-on dc milliammeter to this wire and adjust R135 for

a 'Q' current of 50 mA. Change connection of milliammeter to wire attached to terminal 3 of output transformer T2 and adjust R136 for a 'Q' current of 50 mA. Remove clamp-on milliammeter.

6. Close front panel and secure with four screws previously removed.

### Fuses

The ac primary power fuse is mounted on the front panel (see cover photo). The battery power fuse is located on the rear of the chassis (see Figure 2). If replacement of either fuse is required, determine and correct any cause of failure before replacing fuse. Install only an identical fuse (see PARTS LIST) by unscrewing fuse holder, replacing fuse and resecurig fuse holder.

### Power Transistors

Power transistors Q1 through Q8 are installed on a heat sink, located beneath the heat sink shroud (see Figure 2). Turn off power to the amplifier before removing shroud.

#### CAUTION

DO NOT operate 1590 without the shroud in place or power transistors may overheat. The shroud is a vital requirement for adequate passage of air across the heat sink.

Remove four screws securing heat sink shroud to chassis; lift off shroud. Remove two screws which hold the heat sink assembly to standoff supports. The heat sink assembly (with power transistors) now may be lifted (unplugged) from the chassis.

When replacing or reinstalling power transistors on the heat sink, check that the following conditions are met:

1. Mica insulator is not damaged. If damaged, use new insulator.
2. No grit or metal particles are lodged between transistor and heat sink.
3. Both sides of mica insulator are covered with silicone grease or fluid.
4. Mounting screws of transistor are tight. Heads of transistor socket are not stripped.

### Removal of Circuit Board

If the circuit board assembly must be removed for service, or for access beneath the board, remove the two screws securing the board to standoffs. Then carefully pull the circuit board assembly from the connector.

#### CAUTION

Do not warp, bend or twist the board, or conductor may fracture or lift from the board surface.

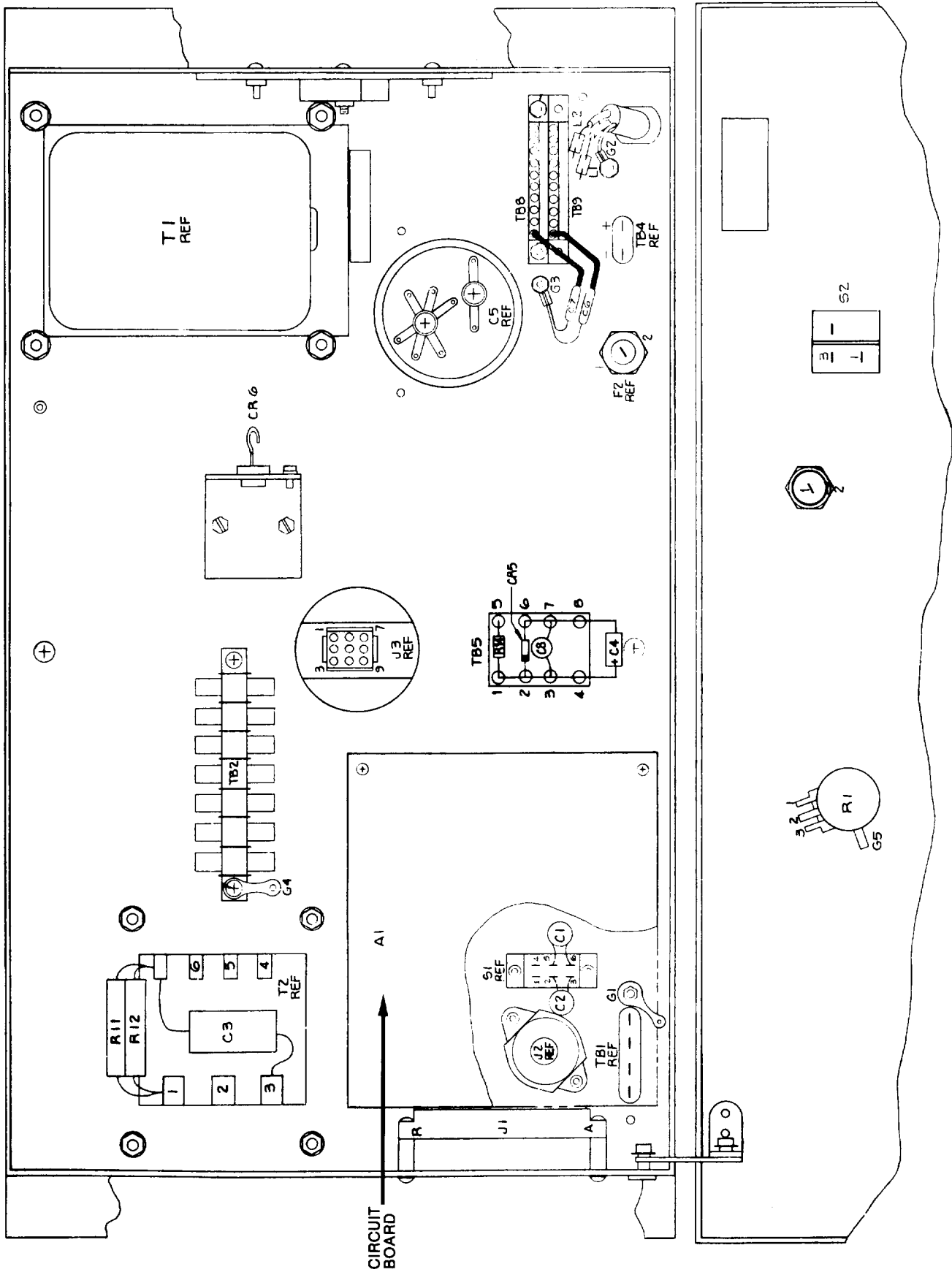

Figure 6. Internal View of 1590E Power Amplifier

Figure 7. Schematic (6D908-19), 1590E Power Amplifier

## PARTS LIST

## MAIN CHASSIS

Reference Designator	Ordering Number	Name and Description
—	27-01-042080-08	Circuit Board Assembly
—	24-04-100527-01	Knob, volume control, 1 1/4"
—	20-04-100525-01	Knob, power, 3/4"
C1	15-06-118653	Cap., .033 $\mu$ F $\pm$ 10%
C2	15-02-100307	Cap., 0.01 $\mu$ F $\pm$ 20%, 100V
C3	15-06-100157-01	Cap., 1 $\mu$ F $\pm$ 10%, 100V
C4	15-01-106575	Cap., 1000 $\mu$ F $\pm$ 50%, 25V
C5	15-01-100299-02	Cap., 13500 $\mu$ F, 35V
C6,7	15-02-122768	Cap., .0033 $\mu$ F $\pm$ 20%, 1.4 KV
C8	15-02-100109	Cap., .1 $\mu$ F $\pm$ 20%, 100V
CR1	48-01-107429-01	Stabistor, STB-568
CF2,3	48-02-042787-01	Rect., silicon, 1A, 400 PIV
CR4	48-01-107271-01	Diode, Zener, 20V $\pm$ 5%, 2W
CR5	48-01-108576-02	Diode, Zener, 15V $\pm$ 5%, 2W
CR6	48-02-108690-01	Rect. 1N3492
CR7	48-02-122651	Rect. F/W Bridge 25A-200V
F1	51-04-100469-01	Fuse, 4A, 125V, slo-blo
F2	51-04-121664-01	Fuse, 10A, 32V
L1,2	56-01-044110-01	Choke, ferrite bead
PL1	39-01-100784	Bulb, INCN 1/4-28V clear
Q1,2,3,4,5,6,7,8		NOTE 1
R1	47-06-042609-01	Pot., 15 K $\Omega$ $\pm$ 20%, audio
R2,3	47-01-100635-01	Res., 22 $\Omega$ $\pm$ 10%, 1W
R4,5,7,8,9,10	47-02-108691-01	Res., 0.3 $\Omega$ $\pm$ 10%, 5W
R6	47-01-100652-01	Res., 1.8 K $\Omega$ $\pm$ 10%, 1W
R11,12	47-02-108692-01	Res., 1 $\Omega$ $\pm$ 10%, 5W
R13	47-01-102551-01	Res., 470 $\Omega$ $\pm$ 10%, 1W
R14	47-02-100715-01	Res., 200 $\Omega$ $\pm$ 10%, 5W
R15	47-02-100713-01	Res., 47 $\Omega$ $\pm$ 10%, 5W
R16	47-01-102306-01	Res., 56 K $\Omega$ $\pm$ 5%, 1/2W
R137,138	47-01-102253-01	Res., 360 $\Omega$ $\pm$ 5%, 1/2W
S1	51-02-100992-01	Switch, DPST, rotary
S2	51-02-124346	Sw. RCKR, SPST, 16A
T1	56-08-007062-16	Transformer, power
T2	56-07-016802-04	Transformer, output
TB1	21-04-122180	Terminal Block, 4-terminal
TB2	21-04-121277-01	Terminal Board, 7-terminal
TB4	21-04-122181	Terminal Strip, 2-terminal
TB5	21-04-101015-01	Terminal board, 8-terminal

## NOTE 1:

Two different output transistors have been used, please verify the device installed before placing orders:

2N6254 ordering number 48-03-040934

2N5878 ordering number 48-03-124447

## CIRCUIT BOARD ASSEMBLY

Reference Designator	Ordering Number	Name and Description
C101	15-01-100156-01	Cap., 1 $\mu$ F, 25V
C102	15-02-107470-01	Cap., 220 pF $\pm$ 10%, 100V
C103	15-02-107521-01	Cap., 330 pF $\pm$ 10%, 100V
C104,105	15-01-108543-01	Cap., 5 $\mu$ F, 25V
C106,107	15-06-102605-01	Cap., 0.47 $\mu$ F $\pm$ 10%, 100V
C108,109	15-02-100305-01	Cap., 0.005 $\mu$ F $\pm$ 20%, 100V
C110,111	15-02-100307-01	Cap., 0.01 $\mu$ F $\pm$ 10%, 100V
C112	15-02-100109	Cap., .1 $\mu$ F $\pm$ 20%, 100V
C113	15-01-122935	Cap., 10 $\mu$ F $\pm$ 20%, 35V
C120,121,122	15-02-107454-01	Cap., 100 pF $\pm$ 10%, 100V
CR101,102,103,104,105,106	48-01-107017-01	Diode, 1N456A
Q101,103,108,109	48-03-101098-04	Transistor, 2N2712, selected
Q102	48-03-107102	Transistor, 2N3906, selected
Q104,105	48-03-119140-02	Transistor, 2N5308, selected
Q106,107	48-03-107447-04	Transistor, 2N5320, selected
R101	47-01-100479-01	Res., 680 K $\Omega$ $\pm$ 10%, 1/4W
R102	47-01-109298	Res., 180 $\Omega$ $\pm$ 5%, 1/4W
R103,106,110	47-01-102094	Res., 4.7 K $\Omega$ $\pm$ 5%, 1/4W
R104	47-01-102088	Res., 2.7 K $\Omega$ $\pm$ 5%, 1/4W
R105	47-01-102086	Res., 2.2 K $\Omega$ $\pm$ 5%, 1/4W
R107	47-01-109204	Res., 470 K $\Omega$ $\pm$ 5%, 1/4W
R108,109	47-01-102102-01	Res., 10 K $\Omega$ $\pm$ 5%, 1/4W
R111,112	47-01-102127	Res., 100 K $\Omega$ $\pm$ 5%, 1/4W
R113	47-01-102105-01	Res., 13 K $\Omega$ $\pm$ 5%, 1/4W
R114	47-01-102082	Res., 1.5 K $\Omega$ $\pm$ 5%, 1/4W
R115,117	47-01-102030-01	Res., 10 $\Omega$ $\pm$ 5%, 1/4W
R116,135,136	47-05-014697-01	Pot., 50 $\Omega$ $\pm$ 20%, 2W
R118,119	47-01-102074	Res., 680 $\Omega$ $\pm$ 5%, 1/4W
R120,123	47-01-100642-01	Res., 330 $\Omega$ $\pm$ 10%, 1W
R121,122	47-01-102232	Res., 47 $\Omega$ $\pm$ 5%, 1/2W
R124	47-01-102042	Res., 33 $\Omega$ $\pm$ 5%, 1/4W
R125	47-01-102058	Res., 150 $\Omega$ $\pm$ 5%, 1/4W
R126,127	47-01-102253-01	Res., 360 $\Omega$ $\pm$ 10%, 1/2W
R128	47-01-102048	Res., 56 $\Omega$ $\pm$ 10%, 1/4W
R129,132	47-01-102081-01	Res., 1.3 K $\Omega$ $\pm$ 5%, 1/4W
R130,133	47-01-102100	Res., 8.2 K $\Omega$ $\pm$ 5%, 1/4W
R131,134	47-01-102106	Res., 15 K $\Omega$ $\pm$ 5%, 1/4W
R145,146,147	47-01-102078	Res., 1.0 K $\Omega$ $\pm$ 5%, 1/4W
T101	56-07-015315-11	Transformer, output

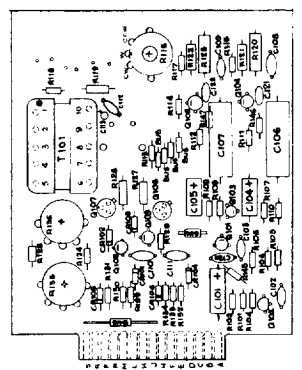
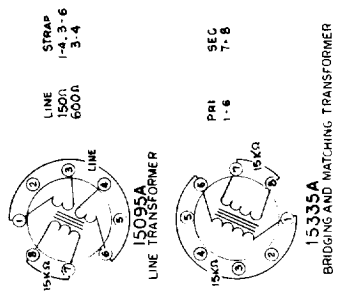
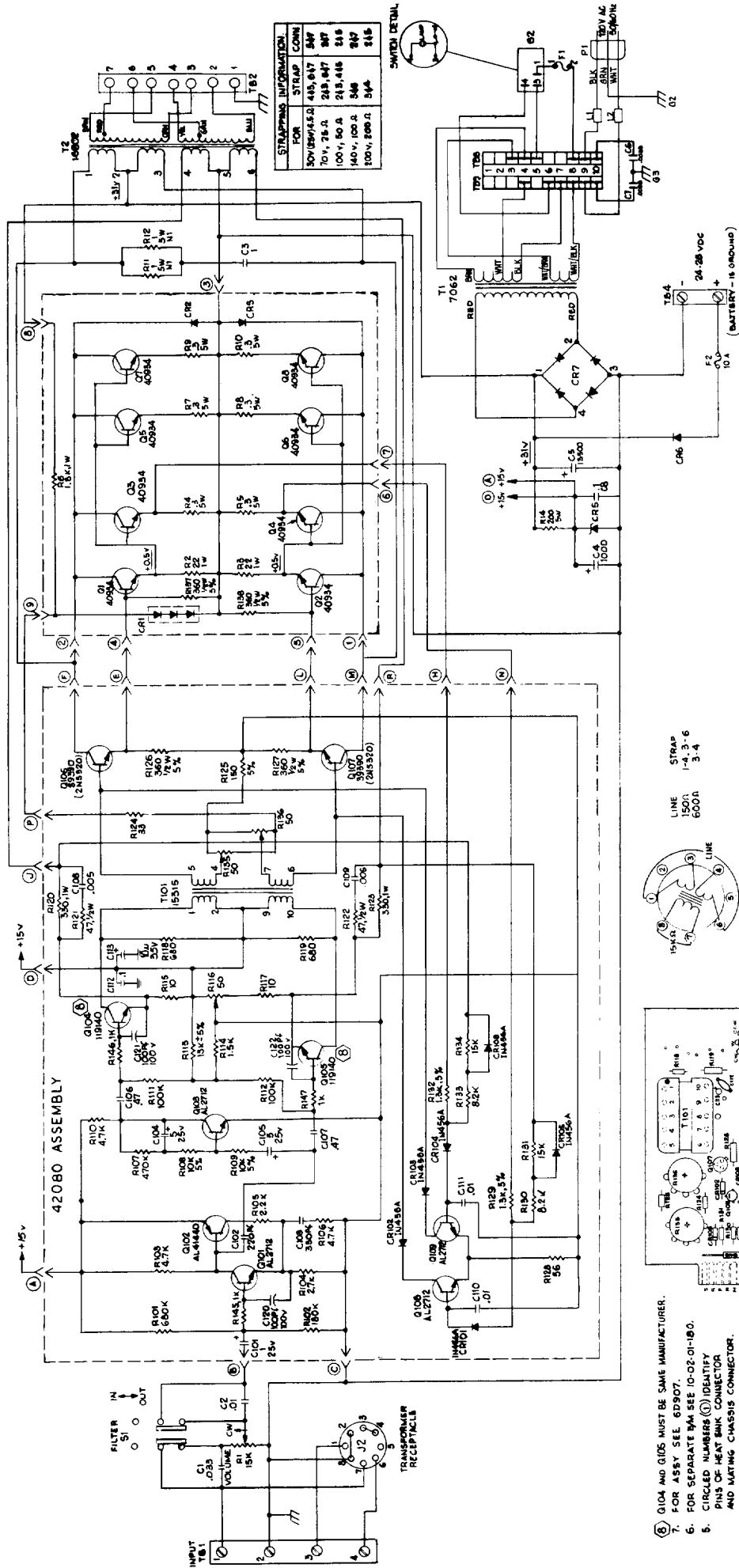

- 6. Q104 AND Q105 MUST BE SAME MANUFACTURER.
- 7. FOR ASSY SEE 6D907.
- 8. FOR SEPARATE SW SEE 10-02-01-18-0.
- 9. CIRCLED NUMBERS (1) REALITY PINS OF HEAT SINK CONNECTOR AND MATING CHASSIS CONNECTOR.
- 10. CIRCLED LETTERS (A) IDENTIFY PINS OF PCB AND MATING CHASSIS CONNECTOR.
- 11. CAPACITOR VALUES ARE IN MICROFARADS.
- 12. RESISTOR VALUES ARE IN OHMS UNLESS OTHERWISE SPECIFIED.

Figure 7. Schematic (6D908-19), 1590E Power Amplifier