

# 8553B DUAL ONE-THIRD OCTAVE PROGRAMMABLE MICROAUDIO EQUALIZER

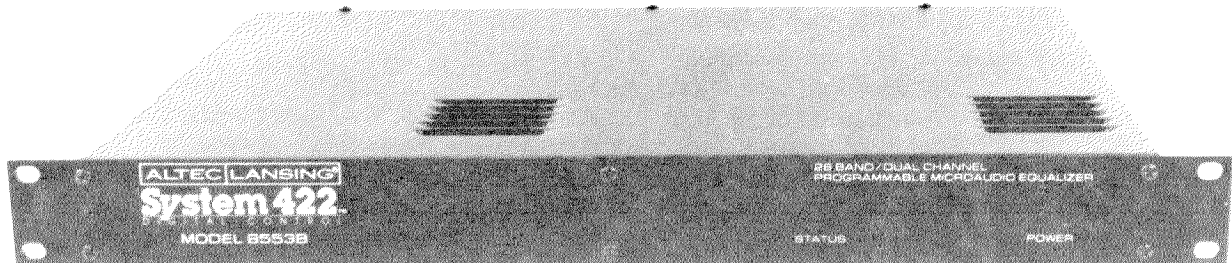

## DESCRIPTION

The ALTEC LANSING model **8553B** is a dual channel programmable one-third octave equalizer. Since the two channels are fully and independently programmable, there are no front panel controls to adjust. This makes the unit completely tamperproof and compact enough to fit into a single rack-space package.

Each channel has 28 programmable one-third octave frequency bands, programmable high and low pass filters, programmable master gain, and nine non-volatile memories providing one default and eight user preset memories. The gain of each frequency band and the master gain are programmable in precise 1 dB steps from -12 dB to +12 dB but can be easily modified by the user to provide  $\pm 6$  dB of boost and cut in 0.5 dB steps. High filter Q's provide improved selectivity resulting in less interaction between adjacent bands. The unit has electronically-balanced inputs and outputs with room inside to mount optional input and output isolation transformers.

The unit also features System422™ Digital Control via the PA-422 communications interface, a new serial interface definition for the control of professional audio products. This makes the **8553B** completely compatible with all other programmable products using the interface.

The PA-422 interface permits high speed communications between the programmer and each

**8553B** equalizer, and up to 250 equalizers can be series-connected to any single PA-422 output port.

The equalizer is fully programmable from most IBM PC-compatible desktop and laptop computers using Acosta-Graphics Release 2.0 System Management Software™ and the **8062A** PA-422 Dual Output Driver Card or the **8060A** RS-232-to-PA-422 converter. The **8062A** is an IBM PC XT/AT-compatible plug-in accessory card with two PA-422 outputs. The two ports permit independent control of up to 500 programmable devices. The **8060A** is an RS-232-to-PA-422 serial output converter. Although usable with any PC-type computer, it is especially useful with laptops which may not physically accommodate the **8062A** accessory card. With System422™, the equalizer can also be programmed using user-written custom software developed for specific installations. This permits increased flexibility in system designs where special needs are in order.

With its standard  $\mu$ A-bus port, the **8553B** is also programmable from the **8061A** PC Control Adapter, **8051A** Autoprogrammer, or the **8055B** handheld programmer to the degree of the controller's capability.

The ALTEC LANSING **8553B** Dual Channel Programmable MicroAudio Equalizer provides unmatched power, performance, and flexibility to accommodate present and future system needs.

# SPECIFICATIONS FOR THE 8553B DUAL CHANNEL

<b>Channels:</b>	Two, completely independent	<b>Maximum Level:</b>	+18 dBu
<b>Filter Type:</b>	Active analog 2nd-order bandpass filter set	<b>Output Circuitry:</b>	Electronically-balanced, transformer option
<b>Number of Bands:</b>	28 one-third octave bandpass filters on ISO center frequencies from 31.5 HZ to 16kHz	<b>Type:</b>	20 $\Omega$ balanced 10 $\Omega$ unbalanced
<b><math>\mu</math>A-bus Programmability:</b>	28 one-third octave bandpass filters on ISO center frequencies from 31.5 HZ to 16kHz	<b>Source Impedance:</b>	600 $\Omega$ 's minimum
(using <b>8061A</b> , <b>8051A</b> , or <b>8055B</b> programmers)		<b>Nominal Level:</b>	0 dBu (0.775 V rms)
B/C of each frequency band:	$\pm 12$ dB in 1 dB steps (standard configuration) $\pm 6$ dB in $\frac{1}{2}$ dB steps (with user hardware modification)	<b>Maximum Level:</b>	18 dBm +24 dBu into 2 K $\Omega$ minimum load impedance
Master gain:	$\pm 12$ dB in 1 dB steps (standard configuration) $\pm 6$ dB in $\frac{1}{2}$ dB steps (with user hardware modification)	<b>High Pass Filter:</b>	3-pole (18 dB/octave), programmable frequency
Channel selection:	rear panel toggle switch	<b>Low Pass Filter:</b>	3-pole (18 dB/octave), programmable frequency
<b><math>\mu</math>A-bus Interface Port:</b>		<b>Frequency Response:</b>	20 Hz — 20 kHz, $\pm \frac{1}{2}$ dB (with high and low pass filters OFF)
Type:	Non-standard TTL	<b>Total Harmonic Distortion:</b>	<0.015% (at unity gain from 20 Hz — 20 kHz)
Max. Cable Length:	15 m (50 ft.)	<b>IMD (SMPTE 4:1)</b>	<0.015% (at unity gain)
<b>System 422™ Programmability:</b>		<b>Noise Floor:</b>	< -85 dBm (A-weighted, at unity gain, high and low pass filters OFF)
(using <b>8060A</b> or <b>8062A</b> PA-422 drivers and Acosta-Graphics Release 2.0 System Management Software™)		<b>Dynamic Range:</b>	>105 dB (peak signal to A-weighted background noise, 2 k $\Omega$ load)
B/C of each frequency band:	$\pm 12$ dB in 1 dB steps (standard configuration) $\pm 6$ dB in $\frac{1}{2}$ dB steps (with user hardware modification)	<b>Connectors:</b>	
Master gain:	$\pm 12$ dB in 1 dB steps (standard configuration) $\pm 6$ dB in $\frac{1}{2}$ dB steps (with user hardware modification)	Audio:	12-terminal barrier strip
Low pass filter corner frequency:	5 kHz, 6.3 kHz, 8 kHz, 10 kHz, 12.5 kHz, 16 kHz, & OFF (>50 kHz)	$\mu$ A-bus:	9-pin D-subminiature female connector
High pass filter corner frequency:	OFF (<10 Hz), 40 Hz, 50 Hz, 63 Hz, 80 Hz, 100 Hz, 125 Hz, & 160 Hz	System 422:	9-pin D-subminiature female (output), 9-pin D-subminiature male (input)
Memories:	Default (DEF), 1, 2, 3, 4, 5, 6, 7 & 8	Power:	IEC power connector
Memory pointer:	OFF, 1, 2, 3, 4, 5, 6, 7 & 8	RMS (Remote Memory Select):	9-pin D-subminiature male connector
Channel selection:	1, 2	<b>Controls and Switches:</b>	1 - 2-position toggle switch (for channel selection with $\mu$ A-bus programmers) 1 - 8-position DIP switch (for PA-422 device address selection)
Device Address:	via 8-position DIP switch	<b>Non-volatile Memories:</b>	9 (1 DEF & 8 User memories per channel)
<b>PA-422 Interface Port:</b>		<b>Indicators:</b>	1 - status LED (indicates that device is in the programming mode) 1 - power LED
Type:	Electronically-balanced, meets EIA-422-A	<b>Power Requirements:</b>	100, 120, 200, 220, 240 V ac, 50/60 Hz 50 watts
Baud rate:	19.2 kilobaud	<b>Turn-on Protection:</b>	$\approx$ 3 second turn-on delay circuit, automatic ac failure bypass
Max. cable length:	1.2 kilometers (4,000 ft.)	<b>Operating Temperature Range:</b>	Up to 50°C (122°F)
Linking:	Serial	<b>Dimensions:</b>	
Character frame bits:	1 - start bit 8 - data bits 1 - even parity bit 2 - stop bits	(Depth measured from rear edge of front panel)	
Handshaking:	DSR/DTR	Height:	1.75 in. (4.4 cm)
<b>Input Circuitry:</b>		Width:	19.0 in. (48.2 cm)
Type:	Electronically-balanced, transformer option		
Impedance:	20 k $\Omega$ balanced 15 k $\Omega$ unbalanced		
Nominal Level:	0 dBu (0.775 V rms)		

# CHANNEL PROGRAMMABLE MICROAUDIO EQUALIZER

Depth (unit only)	14.0 in. (35.6 cm)
Depth (with cables)	15.75 in. (40.0 cm)
<b>Weight:</b>	
Net:	15 lbs. (6.8 kg)
Shipping:	16.5 lbs. (7.5 kg)
<b>Color:</b>	Black
<b>Enclosure:</b>	Rack-mount chassis, 3/16 in. aluminum front panel

**Included Accessories:** Rack-mount hardware kit, 9-pin D-subminiature shorting jumper plug, 3 ft. linking cable, IEC power cord, Universal voltage stickers, operating instructions

**Optional Accessories:** 15560A Input/Output isolation transformer

ALTEC LANSING continually strives to improve products and performance. Therefore specifications are subject to change without notice.

IBM®, XT™, AT™ are trademarks of International Business Machines Corporation

Acousta-Graphics™, System422™ are trademarks of Altec Lansing Corporation

## Typical Performance Curves for One Channel of 8553B Dual Channel One-third Octave Equalizer

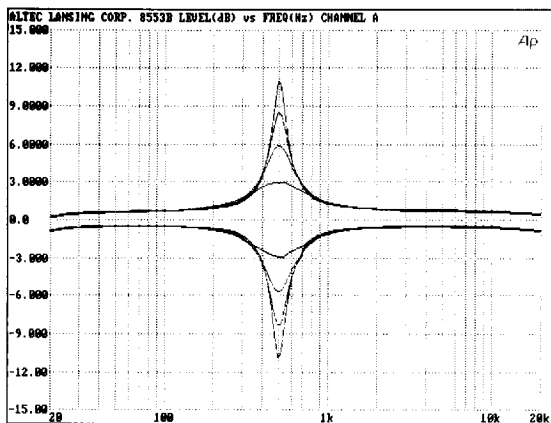

Figure 1. Plot of Amplitude (dB) of 500 Hz band at  $\pm 3$  dB,  $\pm 6$  dB,  $\pm 9$  dB, and  $\pm 12$  dB

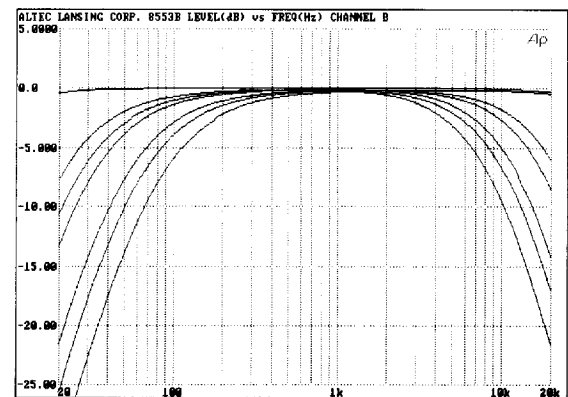

Figure 2. Plot of high and low pass filter responses

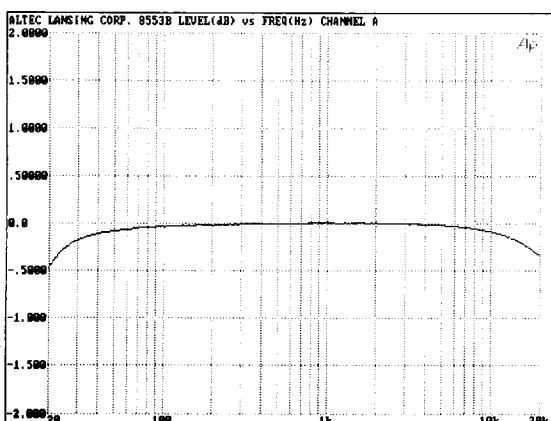

Figure 3. Plot of Frequency Response (all bands set to 0 dB, high and low pass filters set to off)

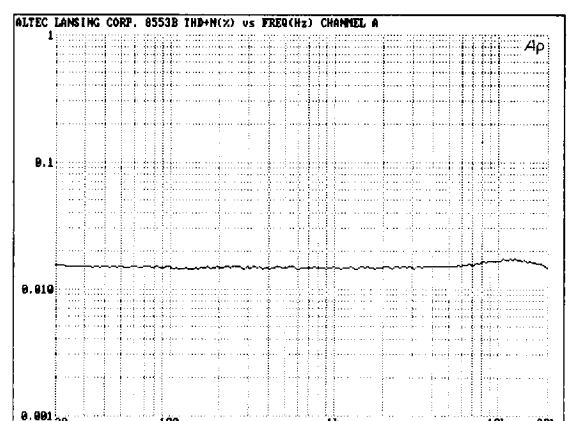

Figure 4. Plot of (THD + Noise) (%) versus Frequency (Hz) (all bands at 0 dB, high and low pass filters set to off)

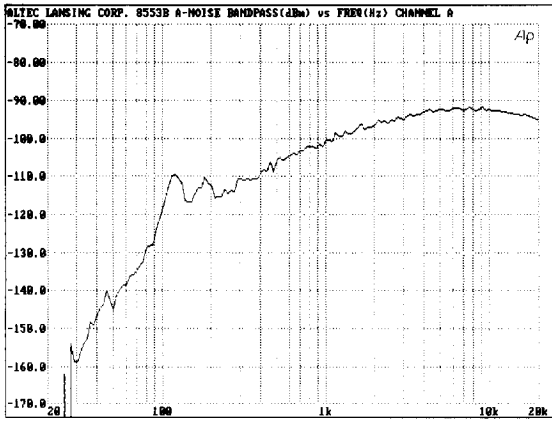

Figure 5. A-weighted Noise (dBm) versus Frequency (Hz) (all bands at 0 dB, high and low pass filters set to off)

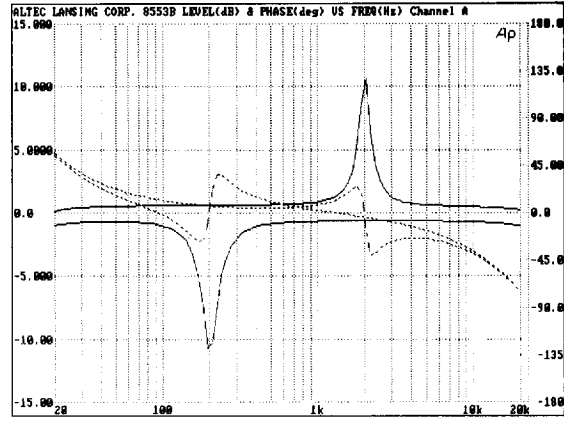

Figure 6. Plot of Amplitude (dB) versus Phase (degrees) with 200 Hz filter set to  $-12$  dB and 2 kHz filter set to  $+12$  dB

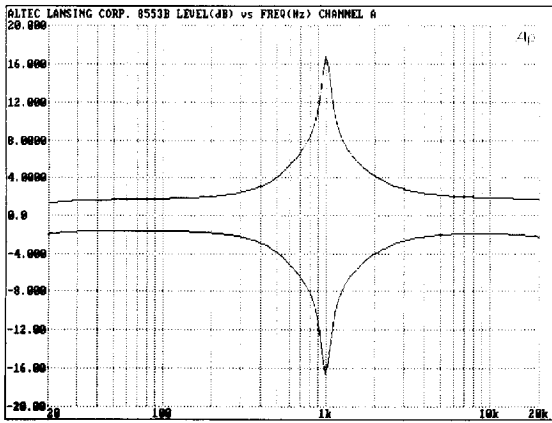

Figure 7. Plot of Amplitude (dB) with 1 kHz band set to  $\pm 12$  dB and adjacent bands (800 Hz and 1.25 kHz) set to  $\pm 4$  dB

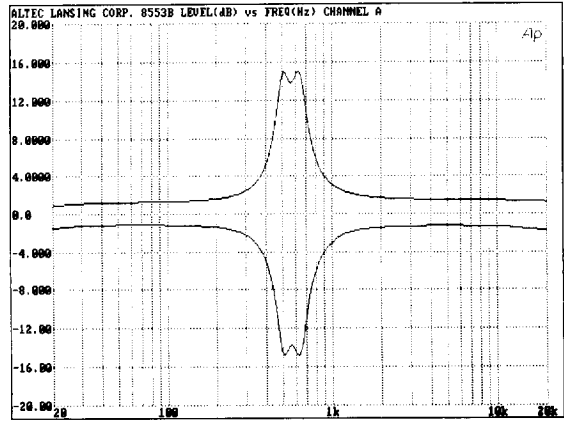

Figure 8. Plot of Amplitude (dB) of 500 Hz and 630 Hz bands set to  $\pm 12$  dB

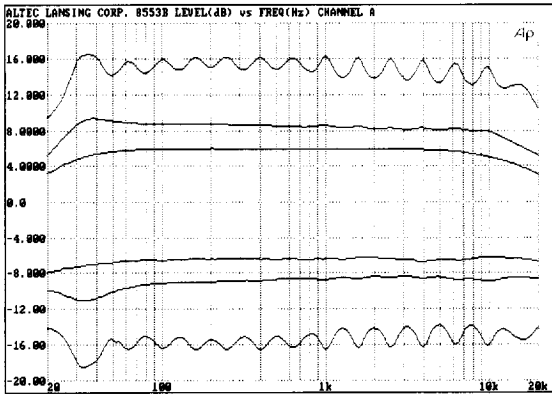

Figure 9. Plot to Amplitude with all filters set to  $\pm 1$  dB,  $\pm 3$  dB, and  $\pm 7$  dB

# SYSTEM 422™ TECHNOLOGY

System 422™ Digital Control, via the new industry standard PA-422 serial communications interface, is the means through which a computer system communicates with programmable audio devices. The PA-422 serial communication interface definition was initiated by Altec Lansing in a paper presented at the 87th Audio Engineering Society Convention in New York City.

The PA-422 interface is easily adaptable to different types of computers and microprocessors. Based on the definition for the control of professional audio products, System 422 digital control via the PA-422 interface makes the Altec Lansing **8553B** dual channel one-third octave programmable micro-audio equalizer completely compatible with all other programmable products using the interface. The PA-422 interface permits high speed bi-directional communications between the programmer and each **8553B** equalizer, and up to 250 equalizers can be serially-connected to any single PA-422 output port.

## Acousta-Graphics Release 2.0 System Management Software™

The Acousta-Graphics System Software will run on IBM PC, XT/AT, or 100% compatible computer systems which use PC-DOS/MS-DOS version 2.1 or greater, and which have at least 512 kbytes of random access memory (RAM). The graphics screens will work with most graphic display adapters with the appropriate video monitors attached. This includes most laptop systems which can display a pixel resolution of 640 horizontal by 200 vertical.

From the main graphics screen you can select the particular device, device channel and user memory you want to program. You can also program each frequency band, the high and low pass filters, the master gain, and the memory pointer value. And you can recall data from any memory in the device. The software can print text and graphics on most dot matrix printers and laser printers that can emulate the HP LaserJet Series II.

The **8060A** provides one PA-422 output port from any standard RS-232 serial port. Although usable with desktop computers, it is especially useful with laptops which may not physically accommodate the **8062A** internal plug-in accessory card. With **System 422™**, the equalizer can also be programmed using custom software developed for specific applications. With its standard  $\mu$ A-bus port, the **8553B** is also programmable from the **8061A** PC control adapter, **8051A** autoprogrammer, or the **3055B** handheld programmer, or to the degree of the controller's capability.

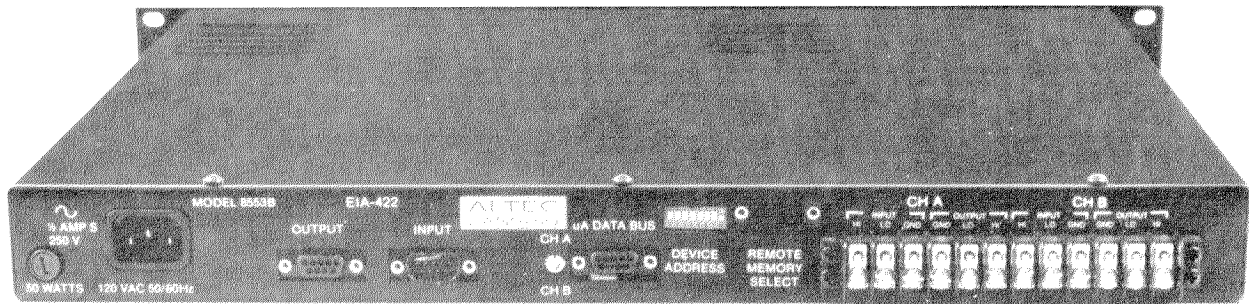

## ARCHITECT'S AND ENGINEER'S SPECIFICATIONS

The equalizer shall be the Altec Lansing model **8553B** dual channel one-third octave programmable microaudio equalizer. It shall have two channels. Each channel shall have 28 one-third octave frequency bands at the preferred ISO center frequencies between 31.5 Hz and 16 kHz inclusively, and a master gain control. The gain of each frequency band and the master shall be programmable in 1 dB steps from  $-12$  dB to  $+12$  dB. There shall be no internal or external user gain controls, or other front panel controls. The equalizer shall be microprocessor-controlled and programmable only from an external means.

Each channel shall have a 3-pole (18 dB/octave) high pass filter with software-selectable corner frequencies. The corner frequencies of said filter shall be  $<10$  Hz (OFF state), 40 Hz, 50 Hz, 63 Hz, 80 Hz, 100 Hz, 125 Hz, and 160 Hz. There shall also be a 3-pole (18 dB/octave) low pass filter for each channel with software-selectable corner frequencies. These frequencies shall be 5 kHz, 6.3 kHz, 8 kHz, 10 kHz, 12.5 kHz, 16 kHz, and 50 kHz (OFF state). The inputs and outputs of the equalizer shall be electronically-balanced with provisions for the inclusion of optional input and

output signal isolation transformers.

Each channel shall have nine non-volatile memories, one power-up or default memory containing the actual "live" settings and eight user memories for storing additional preset equalization settings. One programmable non-volatile memory pointer for each channel shall be provided to permit quick changes on cue. Said memory pointer shall have the capability to be disabled or to "point" to one of the eight user memories. The equalizer shall have a PA-422-compatible device interface port as well as a standard  $\mu$ A-bus programming port for backwards compatibility.

The equalizer shall meet the following performance criteria. Maximum input level: at least 6.16 V rms. Input impedance: at least 15 k $\Omega$ . Maximum output power level: at least  $+18$  dBm. Output noise:  $<-85$  dBm A-wtd. (all gains at unity). Dynamic range: at least 105 dB. THD:  $<0.015\%$  (all gains at unity). IMD (SMPTE 4:1):  $<0.015\%$  (all gains at unity). The equalizer shall be operable from a 120V ac, 60 Hz supply.



a MARK IV company

P.O. BOX 26105 • OKLAHOMA CITY, OK 73126-0105 • U.S.A. • 405/324-5311 or FAX: 405/324-8981

©1990 Altec Lansing Corporation

# DIGITAL CONTROLLED EQUALIZATION

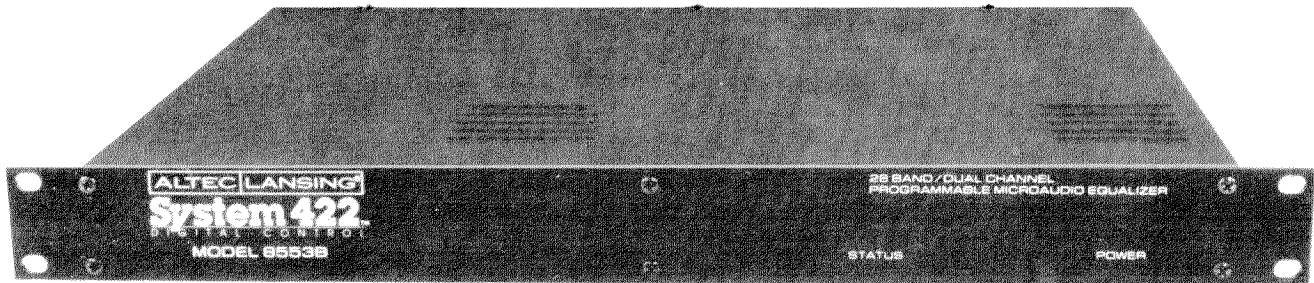

The Industry Standard PA-422 Permits High Speed Communications

- ELECTRONICALLY-BALANCED INPUTS AND OUTPUTS
  - FULLY AND INDEPENDENTLY PROGRAMMABLE
  - ROOM INSIDE FOR OPTIONAL TRANSFORMERS
  - VIRTUALLY UNLIMITED APPLICATIONS
    - TAMPERPROOF AND COMPACT
    - QUICK AND RELIABLE
    - 3 YR. WARRANTY
    - DUAL CHANNEL
    - 28 BANDS

**ALTEC LANSING®**  
**System 422™**  
DIGITAL · CONTROL

## SPECIFICATIONS FOR THE 8553B DUAL CHANNEL PROGRAMMABLE MICROAUDIO EQUALIZER

<b>Channels:</b>	Two, completely independent	<b>Memory pointer:</b>	OFF, 1, 2, 3, 4, 5, 6, 7, & 8
<b>Filter Type:</b>	Active analog 2nd-order bandpass filter set	<b>Channel selection:</b>	1, 2
<b>Number of Bands:</b>	28 one-third octave bandpass filters on ISO center frequencies from 31.5 Hz to 16kHz.	<b>Device Address:</b>	via 8-position DIP switch
<b><math>\mu</math>A-bus Programmability:</b> (using 8061A, 8051A, or 8055B programmers)		<b>PA-422 Interface Port:</b>	
B/C of each frequency band:	$\pm 12$ dB in 1 dB steps (standard configuration) $\pm 6$ dB in $\frac{1}{2}$ dB steps (with user hardware modification)	<b>Type:</b>	Electronically-balanced, meets EIA-422-A
Master gain:	$\pm 12$ dB in 1 dB steps (standard configuration) $\pm 6$ dB in $\frac{1}{2}$ dB steps (with user hardware modification)	<b>Baud rate:</b>	19.2 kilobaud
Channel selection:	rear panel toggle switch	<b>Max. cable length:</b>	1.2 kilometers (4,000 ft.)
		<b>Linking:</b>	Serial
		<b>Character frame bits:</b>	1 - start bit 8 - data bits 1 - even parity bit 2 - stop bits
		<b>Handshaking:</b>	DSR/DTR
<b><math>\mu</math>A-bus Interface Port:</b>		<b>Input Circuitry:</b>	
Type:	Non-standard TTL	<b>Type:</b>	Electronically-balanced, transformer option
Max. Cable Length:	15 m (50 ft.)	<b>Impedance:</b>	20 k $\Omega$ balanced 15 k $\Omega$ unbalanced
		<b>Nominal Level:</b>	0 dBu (0.775 V rms)
		<b>Maximum Level:</b>	+18 dBu
<b>System422™ Programmability:</b> (using 8060A or 8062A PA-422 drivers and Acousta-Graphics Release 2.0 System Management Software™)		<b>Output Circuitry:</b>	
B/C of each frequency band:	$\pm 12$ dB in 1 dB steps (standard configuration) $\pm 6$ dB in $\frac{1}{2}$ dB steps (with user hardware modification)	<b>Type:</b>	Electronically-balanced, transformer option
Master gain:	$\pm 12$ dB in 1 dB steps (standard configuration) $\pm 6$ dB in $\frac{1}{2}$ dB steps (with user hardware modification)	<b>Source Impedance:</b>	20 $\Omega$ balanced 10 $\Omega$ unbalanced
Low pass filter corner frequency:	5 kHz, 6.3 kHz, 8 kHz, 10 kHz, 12.5 kHz, 16 kHz, & OFF (>50 kHz)	<b>Load Impedance:</b>	600 $\Omega$ 's minimum
High pass filter corner frequency:	OFF (<10 Hz), 40 Hz, 50 Hz, 63 Hz, 80 Hz, 100 Hz, 125 Hz, & 160 Hz	<b>Nominal Level:</b>	0 dBu (0.775 V rms)
Memories:	Default (DEF), 1, 2, 3, 4, 5, 6, 7, & 8	<b>Maximum Level:</b>	18 dBm +24 dBu into 2 K $\Omega$ minimum load impedance
		<b>High Pass Filter:</b>	3-pole (18 dB/octave), programmable frequency
		<b>Low Pass Filter:</b>	3-pole (18 dB/octave), programmable frequency
		<b>Frequency Response:</b>	20 Hz — 20 kHz, $\pm \frac{1}{2}$ dB (with high and low pass filters OFF)
		<b>Total Harmonic Distortion:</b>	<0.015% (at unity gain from 20 Hz — 20 kHz)
		<b>IMD (SMPTE 4:1):</b>	<0.015% (at unity gain)
		<b>Noise Floor:</b>	<-85 dBm (A-weighted, at unity gain, high and low pass filters OFF)



<b>Dynamic Range:</b>	>105 dB (peak signal to A-weighted background noise, 2 k $\Omega$ load)	<b>Turn-on Protection:</b>	$\approx$ 3 second turn-on delay circuit, automatic ac failure bypass
<b>Connectors:</b>		<b>Operating Temperature Range:</b>	Up to 50 °C (122 °F)
Audio:	12-terminal barrier strip	<b>Dimensions:</b>	(Depth measured from rear edge of front panel)
$\mu$ A-bus:	9-pin D-subminiature female connector	Height:	1.75 in. (4.4 cm)
System422:	9-pin D-subminiature female (output), 9-pin D-subminiature male (input)	Width:	19.0 in. (48.2 cm)
Power:	IEC power connector	Depth (unit only):	14.0 in. (35.6 cm)
RMS (Remote Remory Select):	9-pin D-subminiature male connector	Depth (with cables):	15.75 in. (40.0 cm)
<b>Controls and Switches:</b>	1 - 2-position toggle switch (for channel selection with $\mu$ A-bus programmers) 1 - 8-position DIP switch (for PA-422 device address selection)	<b>Weight:</b>	
		Net:	15 lbs. (6.8 kg)
		Shipping:	16.5 lbs. (7.5 kg)
		<b>Color:</b>	Black
		<b>Enclosure:</b>	Rack-mount chassis, 3/16 in. aluminum front panel
<b>Non-volatile Memories:</b>	9 (1 DEF & 8 User memories per channel)	<b>Included Accessories:</b>	Rack-mount hardware kit, 9-pin D-subminiature shorting jumper plug, 3 ft. linking cable, IEC power cord, Universal voltage stickers, operating instructions
<b>Indicators:</b>	1 - status LED (indicates that device is in the programming mode) 1 - power LED	<b>Optional Accessories:</b>	<b>15560A</b> Input/Output isolation transformer
<b>Power Requirements:</b>	100, 120, 200, 220, 240 V ac, 50/60 Hz, 50 watts		

ALTEC LANSING continually strives to improve products and performance. Therefore specifications are subject to change without notice.

IBM®, XT™, AT™ are trademarks of International Business Machines Corporation

Acosta-Graphics™,  
System422™ are trademarks of Altec Lansing Corporation

Typical Performance Curves for One Channel of 8553B  
Dual Channel One-third Octave Programmable Equalizer

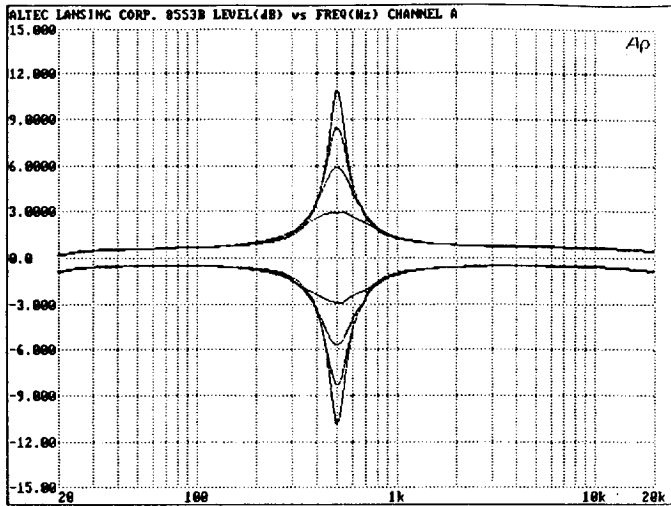

Figure 1. Plot of Amplitude (dB) of 500 Hz band at  $\pm 3$  dB,  $\pm 6$  dB,  $\pm 9$  dB, and  $\pm 12$  dB

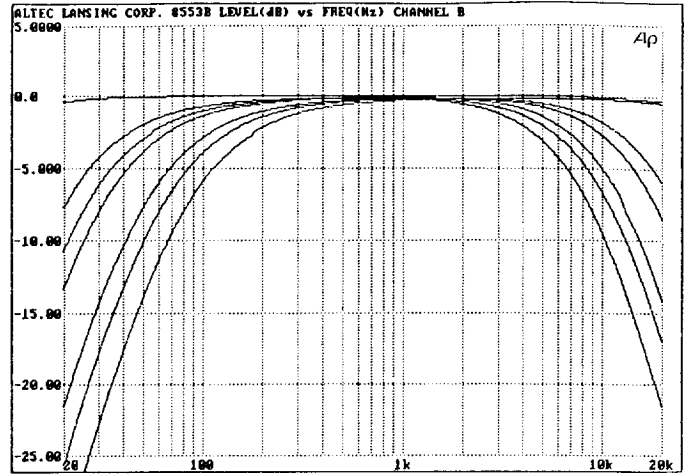

Figure 2. Plot of high and low pass filter responses

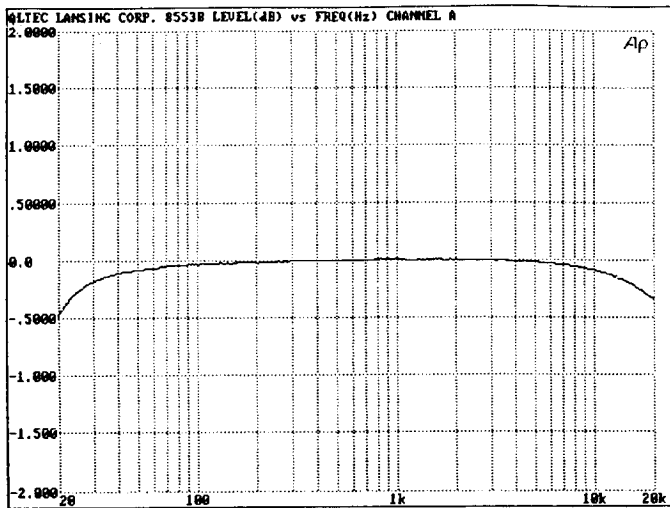

Figure 3. Plot of Frequency Response (all bands set to 0 dB, high and low pass filters set to off)

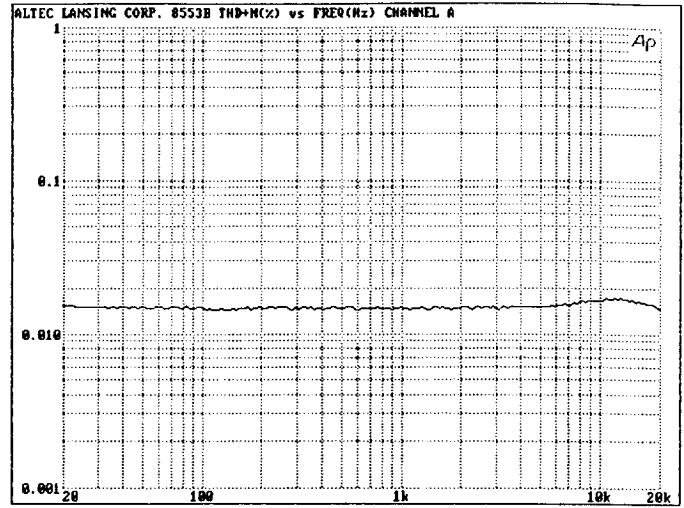

Figure 4. Plot of (THD + Noise) (%) versus Frequency (Hz) (all bands at 0 dB, high and low pass filters set to off)

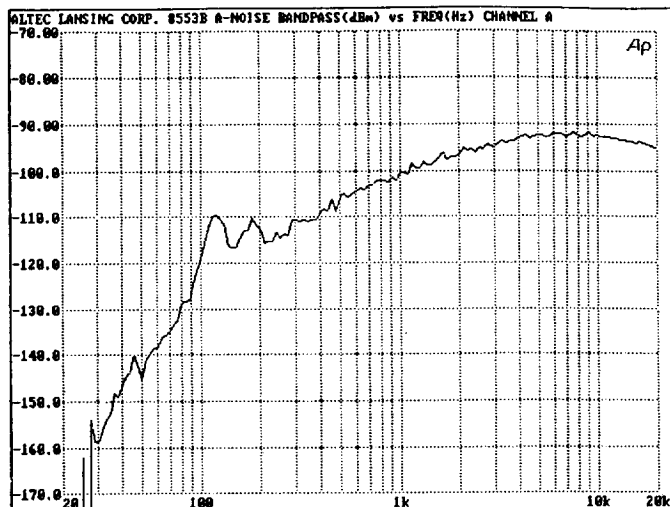

Figure 5. A-weighted Noise (dBm) versus Frequency (Hz) (all bands at 0 dB, high and low pass filters set to off)

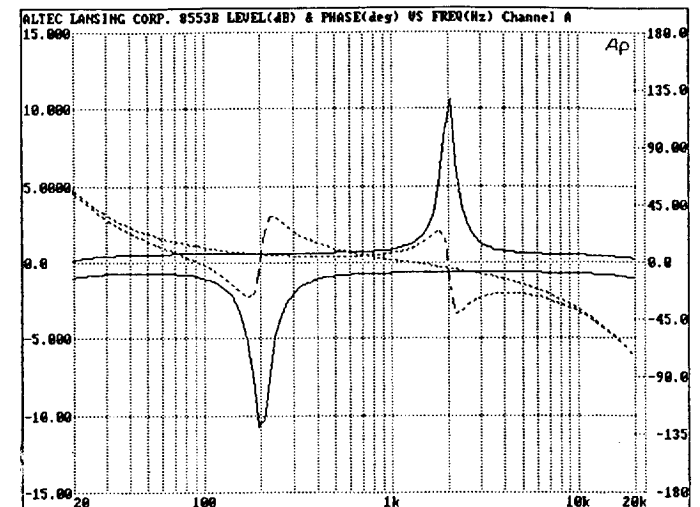

Figure 6. Plot of Amplitude (dB) versus Phase (degrees) with 200 Hz filter set to -12 dB and 2 kHz filter set to +12 dB

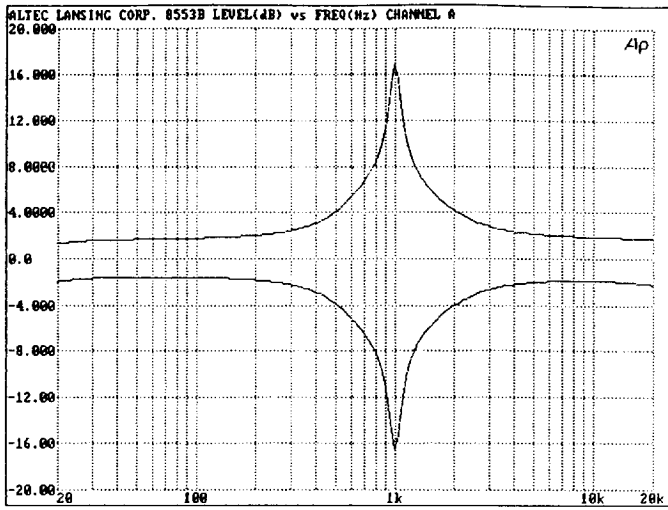

Figure 7. Plot of Amplitude (dB) with 1 kHz band set to  $\pm 12$  dB and adjacent bands (800 Hz and 1.25 kHz) set to  $\pm 4$  dB

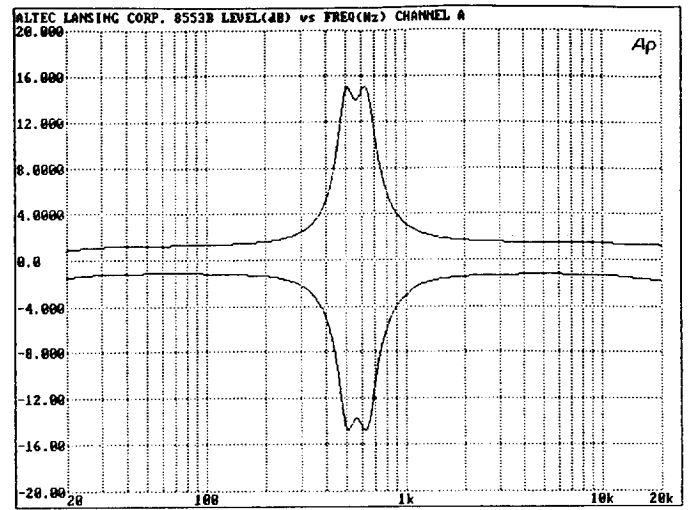

Figure 8. Plot of Amplitude (dB) of 500 Hz and 630 Hz bands set to  $\pm 12$  dB

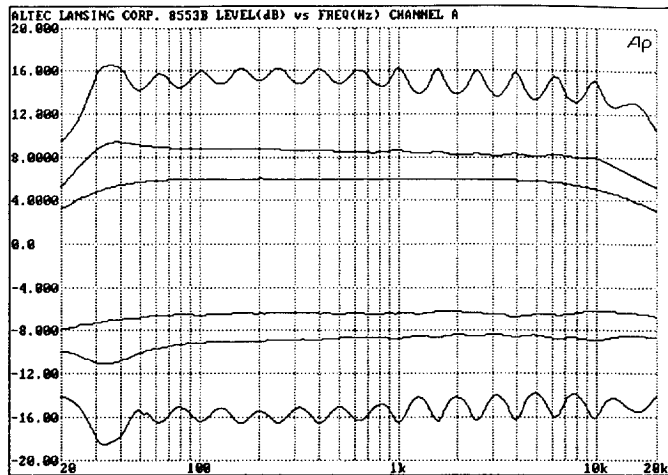
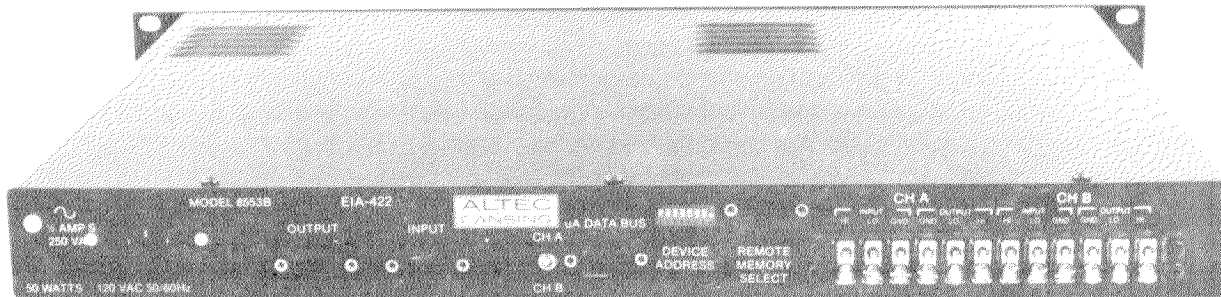

Figure 9. Plot of Amplitude with all filters set to  $\pm 1$  dB,  $\pm 3$  dB, and  $\pm 7$  dB



### ARCHITECT'S AND ENGINEER'S SPECIFICATIONS

The equalizer shall have two channels. Each channel shall have 28 one-third octave frequency bands at the preferred ISO center frequencies between 31.5 Hz and 16 kHz inclusively, and a master gain control. The gain of each frequency band and the master shall be programmable in 1 dB steps from -12 dB to +12 dB. There shall be no internal or external user gain controls, or other front panel controls. The equalizer shall be microprocessor-controlled and programmable only from an external means.

Each channel shall have a 3-pole (18 dB/octave) high pass filter with software-selectable corner frequencies. The corner frequencies of said filter shall be <10 Hz (OFF state), 40 Hz, 50 Hz, 63 Hz, 80 Hz, 100 Hz, 125 Hz, and 160 Hz. There shall also be a 3-pole (18 dB/octave) low pass filter for each channel with software-selectable corner frequencies. These frequencies shall be 5 kHz, 6.3 kHz, 8 kHz, 10 kHz, 12.5 kHz, 16 kHz, and >50 kHz (OFF state). The inputs and outputs of the equalizer shall be electronically-balanced with provisions for the inclusion of optional input and output signal isolation transformers.

Each channel shall have nine non-volatile memories, one power-up or default memory containing the actual "live" settings and eight user memories for storing additional preset equalization settings. One programmable non-volatile memory pointer for each channel shall be provided to permit quick changes on cue. Said memory pointer shall have the capability to be disabled or to "point" to one of the eight user memories. The equalizer shall have a PA-422-compatible device interface port as well as a standard  $\mu$ A-bus programming port for backwards compatibility.

The equalizer shall meet the following performance criteria. Maximum input level: at least 6.16 V rms. Input impedance: at least 15 k $\Omega$ . Maximum output power level: at least +18 dBm. Output noise: <-85 dBm A-wtd. (all gains at unity). Dynamic range: at least 105 dB. THD: <0.015% (all gains at unity). IMD (SMPTE 4:1): < 0.015% (all gains at unity). The equalizer shall be operable from a 120 V ac, 60 Hz supply.

The equalizer shall be the ALTEC LANSING Model 8553B Dual Channel Programmable MicroAudio Equalizer.



P.O. BOX 26105 ♦ OKLAHOMA CITY, OK 73126-0105 ♦ U.S.A. ♦ TELE:405/324-5311 ♦ FAX: 405/324-8981

©1990 ALTEC LANSING CORPORATION

## Table of Contents

1.0 POWER CONNECTIONS .....	7
1.1 For 120 V ac, 50/60 Hz Operation .....	7
1.2 For Other ac Line Voltages .....	7
1.3 Special Meanings for the Power LED .....	7
2.0 SIGNAL CONNECTIONS TO THE 8553B .....	7
2.1 Input Signal Connections .....	7
2.1.1 Connecting Balanced Lines .....	7
2.1.2 Connecting Unbalanced Lines .....	7
2.2 Output Signal Connections .....	7
2.2.1 Connecting Balanced Lines .....	7
2.2.2 Connecting Unbalanced Lines .....	7
3.0 <i>System422</i> <sup>TM</sup> DIGITAL CONTROL AND THE PA-422 COMMUNICATIONS INTER- FACE .....	7
3.1 Setting the Device Address .....	8
3.2 Setting up the $\mu$ A-bus port to Enable PA-422 Interface Operation .....	8
3.3 Interconnecting PA-422 Programmable Devices .....	8
3.4 Programming the 8553B Equalizer from a Computer System Using the PA-422 Interface .....	8
3.4.1 Significance of the Status LED .....	8
3.5 Making Additional Linking Cables .....	8
3.6 Remote Memory Selection .....	8
4.0 USING STANDARD $\mu$ A-BUS PROGRAMMERS WITH THE EQUALIZER .....	9
4.1 Using an 8061A PC Control Adapter to Program the Equalizer .....	9
4.1.1 Connecting an 8061A to the Equalizer .....	9
4.1.2 Using Acousta-Graphics <sup>TM</sup> Release 1.3 and the 8061A to Program the Equal- izer .....	9
4.1.3 Significance of the Status LED .....	9
4.2 Using an 8055B Handheld Programmer to Program the Equalizer .....	9
4.2.1 Connecting an 8055B to the Equalizer .....	9
4.2.2 Using the 8055B to Program the Equalizer .....	10
4.2.3 Significance of the Status LED .....	10
4.3 Using an 8051A Autoprogrammer to Program the Equalizer .....	10
4.3.1 Connecting an 8051A to the Equalizer .....	10
4.3.2 Using the 8051A to Program the Equalizer .....	10
4.3.3 Significance of the Status LED .....	12
5.0 MODIFYING THE 8553B FOR 1/2 dB RESOLUTION .....	12
6.0 INSTALLING THE OPTIONAL INPUT AND OUTPUT ISOLATION TRANSFORM-	

ERS .....	13
7.0 TECHNICAL ASSISTANCE .....	13
8.0 FACTORY SERVICE .....	13
APPENDIX - 8553B DEVICE ADDRESS CODES .....	14

**1.0 POWER CONNECTIONS**

The power transformer has two independent 120 V ac primary windings and each has a 100 V ac tap. The windings can be series-connected or connected in parallel to match the required ac line voltage. This is accomplished by installing a short jumper wire(s) across the numbered pads as indicated in Table I and shown in Figure 1.

**1.1 For 120 V ac, 50/60 Hz Operation**

The 8553B equalizer is normally connected for 120 V ac operation from the factory. Before powering the unit, however, it is always prudent to check the actual internal connections with those shown in Table I.

**1.2 For Other ac Line Voltages**

To connect the power transformer's primary windings for other ac line voltages, proceed as outlined below.

1. Unplug the 8553B from the ac line.
2. Remove and save the 10 screws that secure the top cover to the equalizer. There are 3 screws across the top-front edge of the front panel, 3 across the top-rear edge of the top cover, and 2 on either side.
3. Referring to Figure 1, remove and salvage the jumper wire(s) from the board between pads 1-6 and 3-4.
4. Referring to Table I, solder the wire(s) to the designated pair of pads corresponding to the desired ac line voltage.
5. Replace the slow-blow fuse provided in the fuse holder with one having the proper rating as determined from Table II.
6. Re-install the equalizer's top cover with the 10 screws previously removed.

**1.3 Special Meanings for the Power LED**  
The power LED should always be

brightly illuminated during normal operation. If the LED is ever dimly illuminated, it can mean that the digital circuitry is not functioning or that the non-volatile RAM memory is not retaining data. In either case, the unit must be returned for repair. Refer to Section 8.0 for instructions on returning the unit.

**2.0 SIGNAL CONNECTIONS TO THE 8553B**

**2.1 Input Signal Connections**  
**2.1.1 Connecting Balanced Lines**

Connect the non-inverting (+) side of the line to the "HI" input terminal and the inverting (-) side to the "LO" input terminal. In keeping with standard wiring practices, the shield should not be connected at this end; it should be connected only at the sending end.

**Table I** Line Voltage Conversion Chart

Line Voltage	Connect Pads
100 V ac	2-6, 3-5
120 V ac	1-6, 3-4
200 V ac	2-5
220 V ac	2-4
240 V ac	1-4

**Table II** Primary Fuse Values

Line Voltage	Fuse Value
100 V ac	½ amp, 250 V
120 V ac	½ amp, 250 V
200 V ac	¼ amp, 250 V
220 V ac	¼ amp, 250 V
240 V ac	¼ amp, 250 V

**2.1.2 Connecting Unbalanced Lines**

Connect the "hot" wire to the "HI" input terminal and the returning shield wire to the "GND" input terminal. To avoid a 6 dB drop in level, strap the "LO" input terminal to the "GND" terminal.

**2.2 Output Signal Connections**

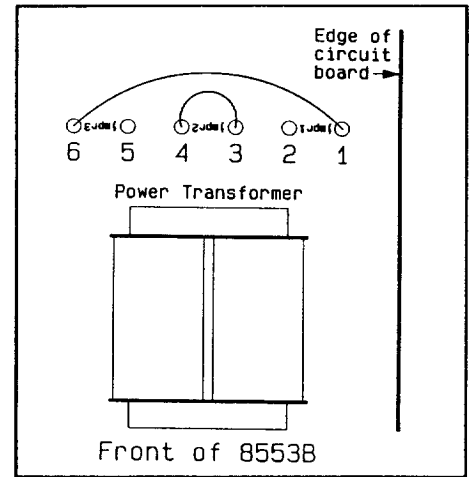

**Figure 1** Location of Primary Voltage Jumper Area

**2.2.1 Connecting Balanced Lines**

Connect the non-inverting (+) side of the line to the "HI" output terminal, the inverting (-) side to the "LO" output terminal, and the shield to the "GND" output terminal.

**2.2.2 Connecting Unbalanced Lines**

Connect the "hot" wire to the "HI" output terminal and the shield wire to the "GND" output terminal.

**NOTE:** DO NOT strap the "LO" output terminal to the "GND" terminal unless the optional output isolation transformer is installed.

Without the optional transformers, the outputs are electronically-balanced. The differential output topology is similar to a power amplifier operating in the bridge mode. Therefore, strapping the "LO" output terminal to ground via the "GND" terminal may cause overheating and ultimate failure of the output stage. To compensate for the 6 dB decrease in output voltage that will result, increase the master gain by 6 dB.

**3.0 System422™ DIGITAL CONTROL AND THE PA-422 COMMUNICATIONS INTERFACE**

If you will not be using the PA-422 high-speed serial communications interface to control the 8553B, you can skip this section and go on to Section 4.0.

The PA-422 communications interface is a high speed bi-directional serial-data transmission system. Since the digital signal lines are electronically-balanced, the programmable devices can be quite far, up to 1.2 kilometers (4,000 ft.) from the controlling means. The following sections describe the setup required to take full advantage of the interface.

### 3.1 Setting the Device Address

Since up to 250 programmable devices may be connected to one PA-422 output port, each device must have a unique "telephone" number assigned. This is accomplished using the 8-position DIP switch located at the rear panel. Since there are 8 binary-weighted switches, there can be at most 256 ( $2^8$ ) possible addresses (telephone numbers). However, six addresses are reserved for future system use. The reserved address codes are 0, 251, 252, 253, 254, 255. Therefore, use only address codes from 1 to 250 as device addresses.

When looking at the rear of the unit, the 8 switch positions on the DIP switch are numbered from 1 to 8 (left to right). The "ON" position of each switch is towards the TOP. To set the switches to a particular address code, refer to chart in the Appendix.

**NOTE:** Each address code must be unique. DO NOT set the switches on two (or more) devices to the same address code setting unless the devices are connected to two different PA-422 output ports.

### 3.2 Setting up the $\mu$ A-bus port to Enable PA-422 Interface Operation

Although the standard  $\mu$ A-bus port is not used when communicating with the device through the PA-422 interface, pins 8 and 9 of the

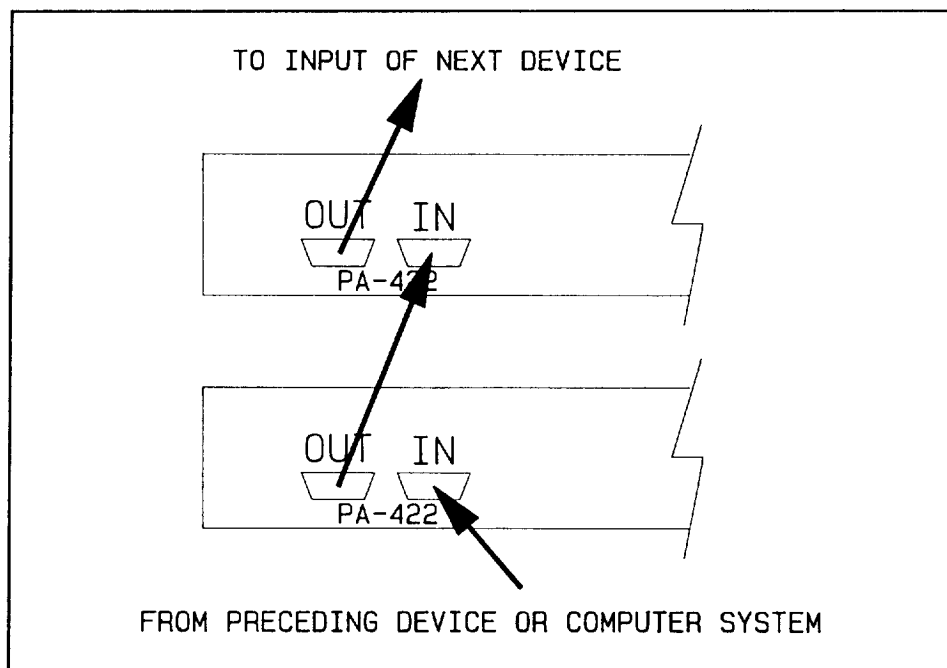

Figure 2 Daisy-chaining PA-422 Programmable Devices

$\mu$ A-bus 9-pin female D-subminiature connector must be shorted together for the PA-422 device interface to operate. This is accomplished via the 9-pin male connector plug normally installed on the port when shipped. If this jumper plug is not already installed, connect it to the  $\mu$ A-bus port connector.

### 3.3 Interconnecting PA-422 Programmable Devices

Each PA-422 device communications interface has an input port and an output port to serially-link (daisy-chain) additional devices. The input port connects to the preceding device or to the controller. The output port should connect to the input of any following device. Refer to Figure 2.

### 3.4 Programming the 8553B Equalizer from a Computer System Using the PA-422 Interface

To program the equalizer, you must use Acousta-Graphics<sup>TM</sup> Release 2.0 System Management Software or the equivalent. Refer now to the software guide provided with the software (Part No. 42-02-027766). Should assistance be required, please

refer to Section 19 on page 26 of the same guide.

### 3.4.1 Significance of the Status LED

Normally, the Status LED is brightly illuminated (the shorting jumper described in Section 3.2 must be installed). When a PA-422 command is issued, the status LED on the receiving device(s) will dim for approximately  $\frac{1}{2}$  second. The resulting "blink" serves to identify the equalizer(s) from others mounted in a rack.

### 3.5 Making Additional Linking Cables

If several equalizers will be installed within the same rack cabinet, you may want to build short linking cables to daisy-chain the devices. Shown in Figure 3 is the wiring diagram of the cable. The cable should be Belden Part No. 9681 or the equivalent.

### 3.6 Remote Memory Selection

If the equalizer is permanently connected to a full-time dedicated PA-422 device controller, the Remote Memory Select (RMS) connector is



inoperable and should not be used. However for an equalizer operating as a "stand-alone" device, meaning that it is not normally connected to any programming means, the RMS connector can be used. This permits simple switch closures to remotely reprogram the equalizer.

Shown in Figure 4 is a diagram equating the hardware-selected memories to the pre-programmed user memories as programmed from a PA-422 device controller.

**NOTE:** The 8553B has two independent sets of user memories numbered from 0 (default) to 8. Each time the equalizer is powered or a new memory selected, it will read the RMS connector to see if a switch is closed. If one is, it will reprogram both channels with the contents of the corresponding memory. Otherwise, it will reprogram both channels with the contents of memory #0.

#### 4.0 USING STANDARD $\mu$ A-BUS PROGRAMMERS WITH THE EQUALIZER

**NOTE:** Since the equalizer has two independent channels, a toggle switch mounted on the rear panel is provided to select the channel to be programmed. If set to "A", for example, channel A will be programmed.

##### 4.1 Using an 8061A PC Control Adapter to Program the Equalizer

If the 8061A MicroAudio PC Control Adapter is not already installed, refer to the Sections 2.1 and 2.2 in the 8061A Operating Instructions (Part No. 42-02-026009).

##### 4.1.1 Connecting an 8061A to the Equalizer

The 8061A comes with two communications cables. Select the cable with the CLEAR heatsink tubing shrunk around one end. It should also have a 9-pin female D-subminiature connector at one end and a 9-pin male D-subminiature connector

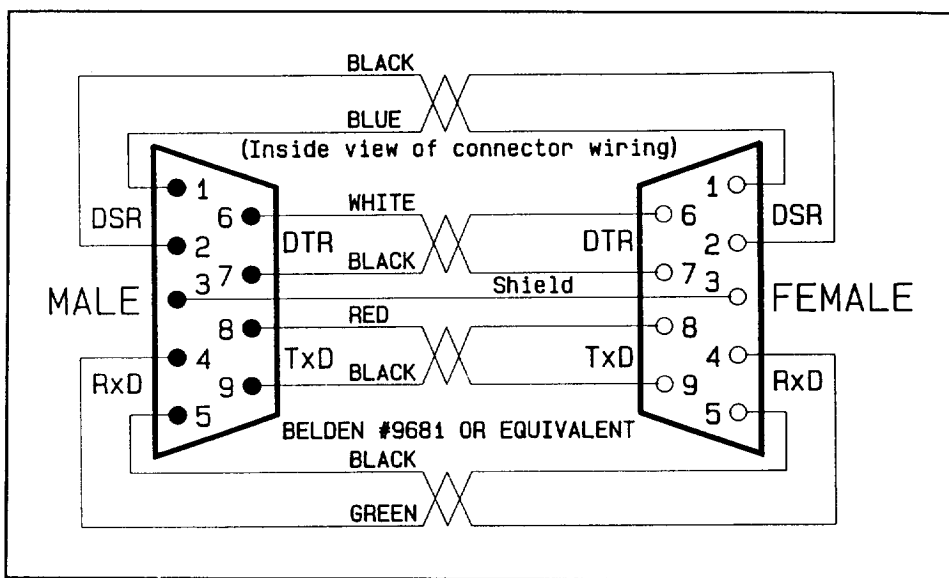

Figure 3 PA-422 Cable Wiring

at the other.

Before powering the computer, connect the 9-pin male end of the cable to the  $\mu$ A-bus female connector on the rear of the equalizer and connect the other end to the 9-pin male connector on the 8061A.

##### 4.1.2 Using Acousta-Graphics™ Release 1.3 and the 8061A to Program the Equalizer

Select the channel to program with the A/B toggle switch located on the rear panel of the equalizer.

To program the equalizer, refer to the Acousta-Graphics™ Release 1.3 Operating Instructions (Part No. 42-02-026902) and any updated information contained in the README file on the software diskette.

If nothing is connected to the RMS connector, you will be programming memory #0 (default memory). To program one of the other memories, short the pin on the RMS connector corresponding to the desired memory number to common. Refer to the wiring diagram shown in Figure 4.

**NOTE:** The 8553B has two independent sets of user memories numbered from 0 (default) to 8. Each time the equalizer is powered or a new memory selected, it will read the RMS

connector to see if a switch is closed. If one is, it will reprogram both channels with the contents of the corresponding memory. Otherwise, it will reprogram both channels with the contents of memory #0.

##### 4.1.3 Significance of the Status LED

Normally, the status LED is dimly illuminated (its "OFF" state). If data is transmitted to the unit, the status LED will illuminate to full brightness ("ON" state) and remain lit as long as the unit is expecting to receive data. The LED will resume its OFF state when data is recalled from the unit or the programmer is disconnected.

Upon powering the equalizer, a recall data command issued to the unit will cause the status LED to flash ON momentarily and return to the OFF state. With each successive recall data command, the status LED will alternate between its ON and OFF states.

##### 4.2 Using an 8055B Handheld Programmer to Program the Equalizer

##### 4.2.1 Connecting an 8055B to the Equalizer

The 8055B does not require an external power supply. All necessary

power is provided by the equalizer through the interconnection cable provided.

The programming cable provided with the 8055B handheld programmer has a 9-pin male D-subminiature connector at one end and a 9-pin female D-subminiature connector at the other. Connect the 9-pin male end of the cable to the  $\mu$ A-bus female connector on the rear of the equalizer and the other end to the 9-pin male connector on the 8055B.

#### 4.2.2 Using the 8055B to Program the Equalizer

Select the channel to program with the A/B toggle switch located on the rear panel of the equalizer.

To program the equalizer, refer to the 8055B Operating Instructions (Part No. 42-02-027617).

If nothing is connected to the RMS connector, you will be programming memory #0 (default memory). To program one of the other memories, short the pin on the RMS connector corresponding to the desired memory number to common. Refer to the wiring diagram shown in Figure 4.

**NOTE:** The 8553B has two independent sets of user memories numbered from 0 (default) to 8. Each time the equalizer is powered or a new memory selected, it will read the RMS connector to see if a switch is closed. If one is, it will reprogram both channels with the contents of the corresponding memory. Otherwise, it will reprogram both channels with the contents of memory #0.

#### 4.2.3 Significance of the Status LED

Normally, the status LED is dimly illuminated. If an 8055B is connected to the standard  $\mu$ A-bus port on the unit, the status LED will illuminate to full brightness and remain lit as long as the unit is expecting to receive data. When a recall data command is issued to the unit, the status LED will momentarily flash to dim and return to full

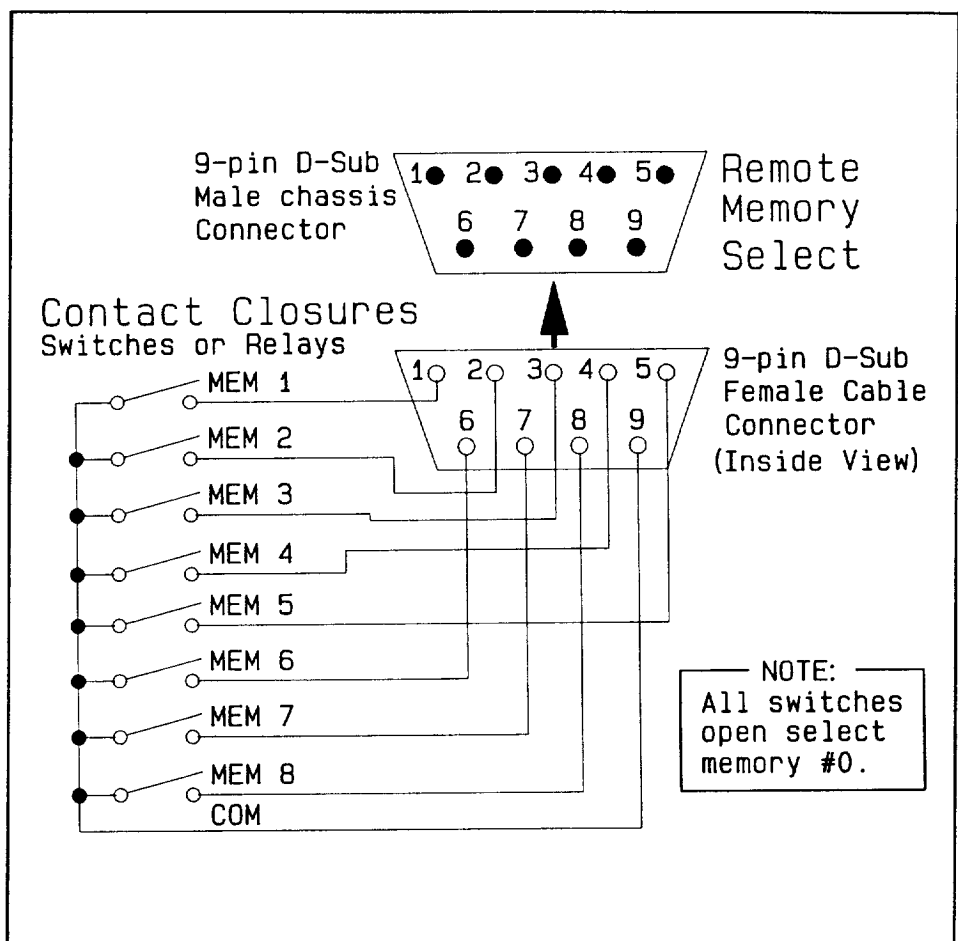

Figure 4 Typical Connections to the Remote Memory Select Connector

brightness.

#### 4.3 Using an 8051A Autoprogrammer to Program the Equalizer

##### 4.3.1 Connecting an 8051A to the Equalizer

The programming cable provided with the 8051A Autoprogrammer has a 9-pin male D-subminiature connector at one end and a 9-pin female D-subminiature connector at the other. Connect the 9-pin male end of the cable to the  $\mu$ A-bus female connector on the rear of the equalizer and the other end to the 9-pin male connector on the 8051A.

##### 4.3.2 Using the 8051A to Program the Equalizer

Select the channel to program with the A/B toggle switch located on the rear panel of the equalizer.

To program the equalizer, refer to the 8051A Operating Instructions

(Part No. 42-02-026007).

If nothing is connected to the RMS connector, you will be programming memory #0 (default memory). To program one of the other memories, short the pin on the RMS connector corresponding to the desired memory number to common. Refer to the wiring diagram shown in Figure 4.

**NOTE:** The 8553B has two independent sets of user memories numbered from 0 (default) to 8. Each time the equalizer is powered or a new memory selected, it will read the RMS connector to see which switch is closed. If one is, it will reprogram both channels with the contents of the corresponding memory. Otherwise, it will reprogram both channels

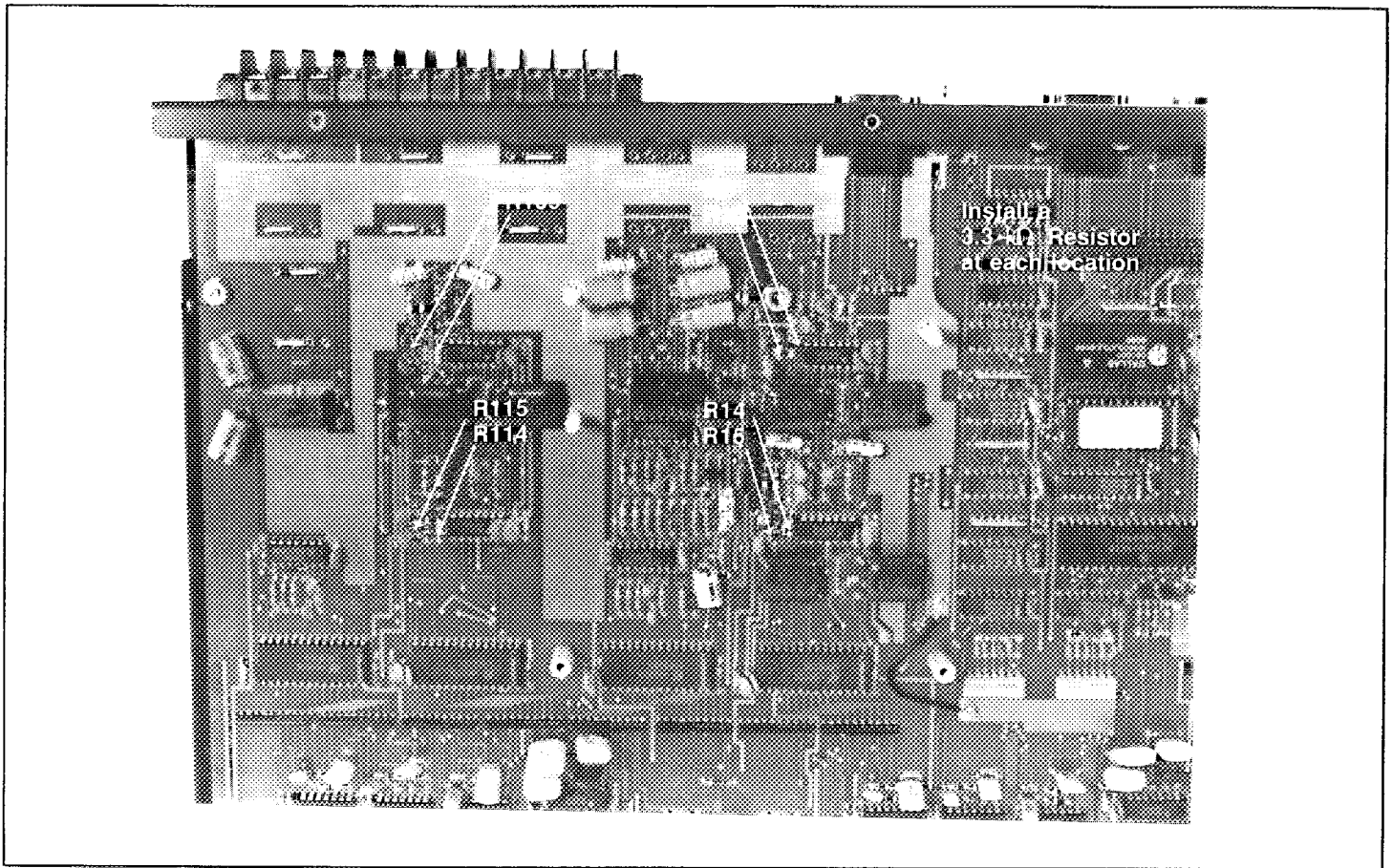

Figure 5 Modifying the Main Circuit Board for  $\pm 6$  dB of Boost/Cut with  $\frac{1}{2}$  dB Resolution

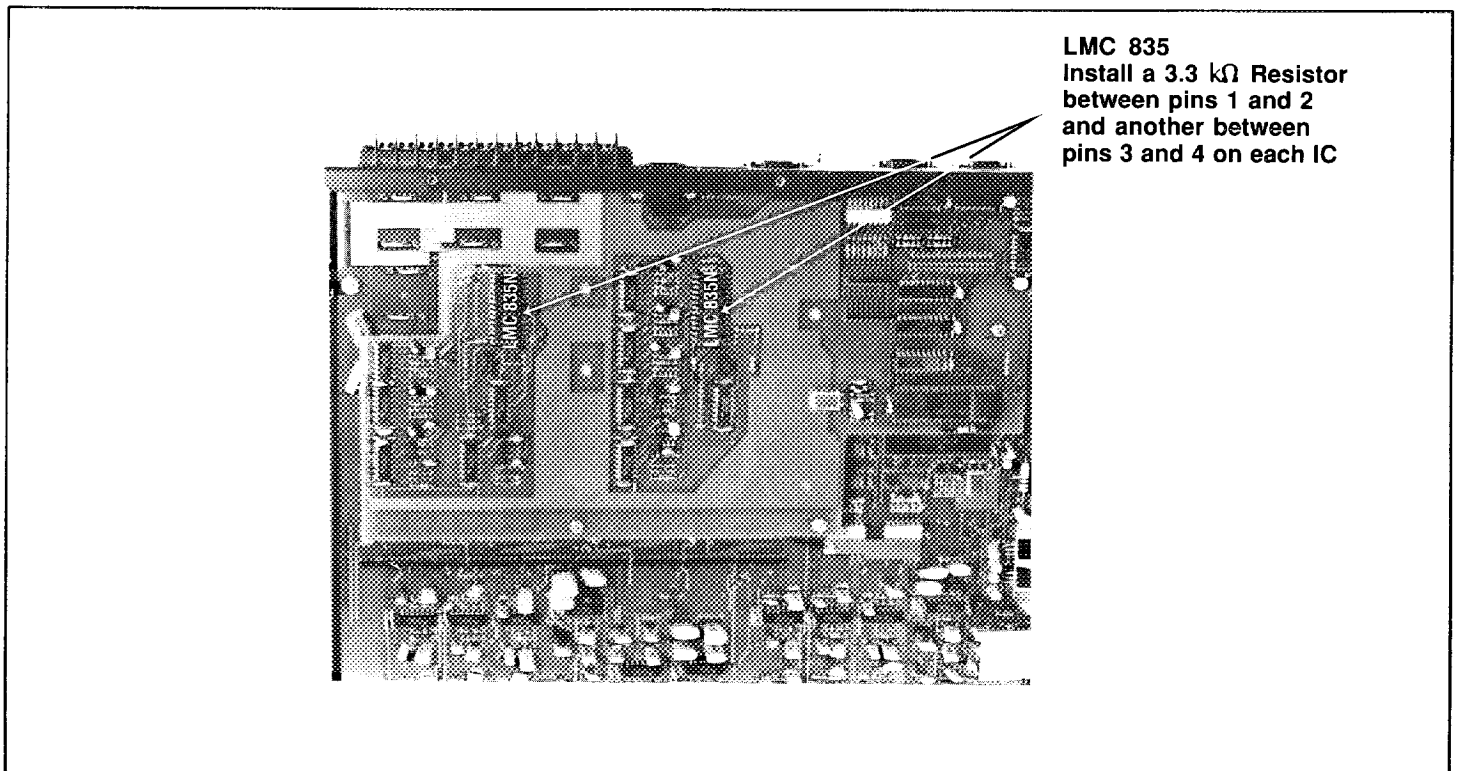

Figure 6 Modifying the Master Gain Circuits for  $\pm 6$  dB of Boost/Cut and  $\frac{1}{2}$  dB Resolution

with the contents of memory #0.

#### 4.3.3 Significance of the Status LED

Normally, the status LED is dimly illuminated. If an 8051A is connected to the standard  $\mu$ A-bus port on the unit, the LED will illuminate to full brightness and remain lit as long as the unit is expecting to receive data. When a recall data command is issued to the unit, the status LED will momentarily flash to dim and return to full brightness.

#### 5.0 MODIFYING THE 8553B FOR 1/2 dB RESOLUTION

The 8553B can be modified to provide a  $\pm 6$  dB boost/cut range with 1/2 dB step sizes for increased resolution. This is accomplished by installing 3.3 k $\Omega$  1/4 watt 5% resistors on the main and upper circuit boards.

To modify the unit, follow the steps below.

1. Unplug the unit from the ac line and disconnect all other cables. If installed in a rack cabinet, remove it and place the unit on a smooth working surface.
2. Remove and save the 10 screws securing the top cover. There are 3 screws across the top-front edge of the front panel, 3 across the top-rear edge of the top cover, and 2 on either side.
3. Remove any screws securing the upper board in place and gently lift from either side until the upper board is free.
4. Several resistors should be omitted. They are designated R<sub>9</sub>, R<sub>10</sub>, R<sub>109</sub>, R<sub>110</sub>, R<sub>14</sub>, R<sub>15</sub>, R<sub>114</sub>, and R<sub>115</sub> as shown in Figure 5. Installing the 3.3 k $\Omega$  resistors in these locations will decrease the maximum boost and cut of each frequency band to  $\pm 6$  dB and provide 1/2 dB resolution. Since the circuit board is double-sided, the resistors can be installed without removing it from the chassis. However, you must trim the leads enough before soldering the resistors in place to insure that the protruding leads extending from the bottom of the circuit board CAN NOT TOUCH the chassis.
5. The master gain circuits are located on the upper circuit board. No provision is made on this board to mount the resistors. To change the master gain, solder a 3.3 k $\Omega$  1/4 watt resistor between pins 1 and 2, and another 3.3 k $\Omega$  1/4 watt resistor between pins 3 and 4 of each LMC835, the large 28 pin IC's shown in Figure 6.
6. Carefully re-install the piggy-back board onto the main circuit board. Make sure all the connector pins mate firmly without bending.
7. Re-install the top cover with the 10 screws previously removed.

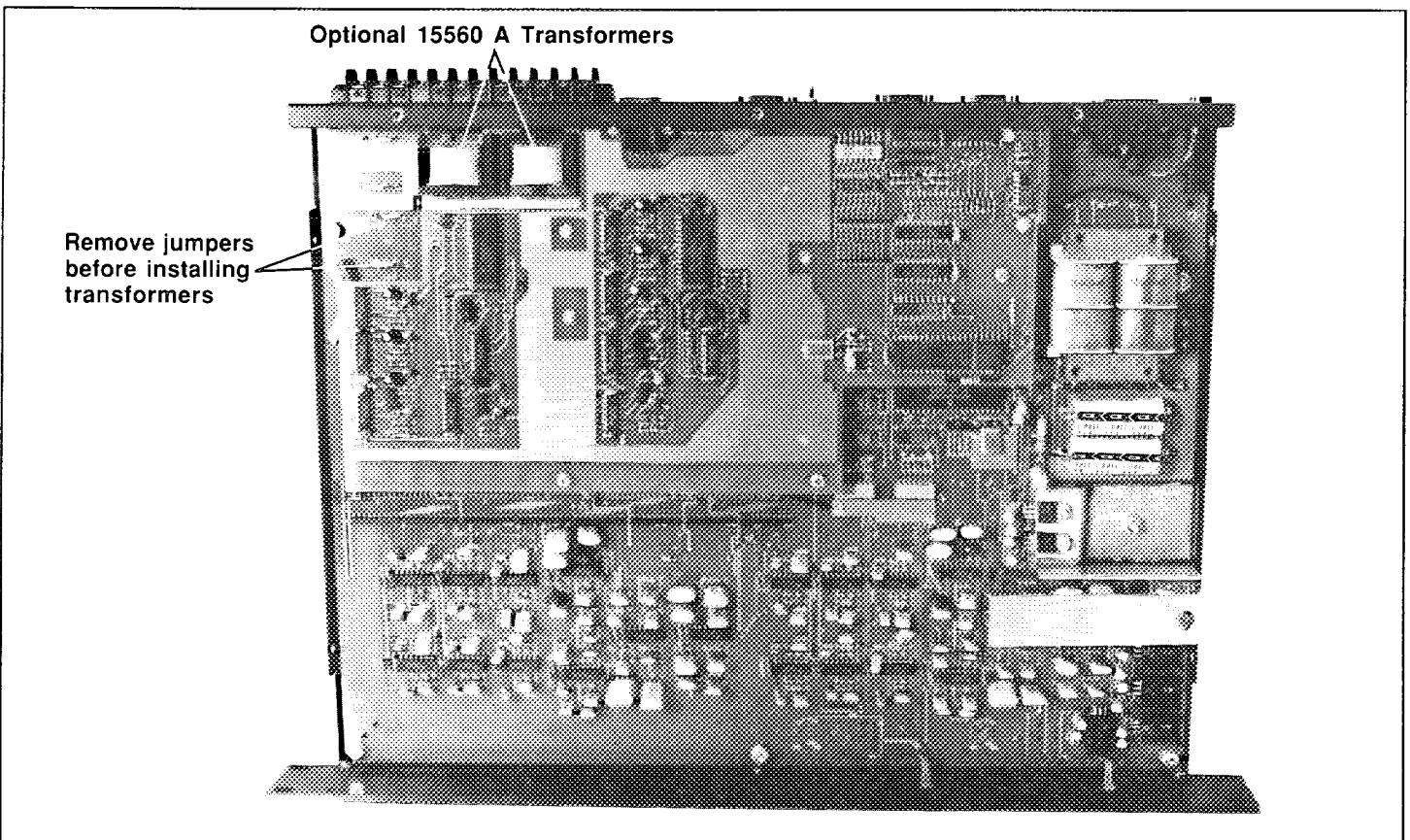

Figure 7 Installation of Optional 15560A Transformers

## 6.0 INSTALLING THE OPTIONAL INPUT AND OUTPUT ISOLATION TRANSFORMERS

The optional transformers install on the main (bottom) circuit board as shown in Figure 7. To install the optional 15560A transformers, follow the steps below.

1. Unplug the unit from the ac line and disconnect all other cables. If installed in a rack cabinet, remove it and place the unit on a smooth working surface.
2. Remove and save the 10 screws securing the top cover. There are 3 screws across the top-front edge of the front panel, 3 across the top-rear edge of the top cover, and 2 on either side.
3. There are 4 exposed transformer sites located behind the barrier strip connector. These are labeled T<sub>2</sub>, T<sub>5</sub>, T<sub>4</sub>, and T<sub>7</sub>. Remove the 2 plug-in jumpers from the flush-mounted sockets within each transformer-location site.

4. The 15560A transformers have a polarized mounting pin arrangement and can only be installed one way. Test the orientation first before pressing each one firmly into place.
5. Re-install the top cover with the 10 screws previously removed.

## 7.0 TECHNICAL ASSISTANCE

If you need technical assistance, please write

Altec Lansing Corporation  
Attn: Technical Services Manager  
P.O. Box 26105  
Oklahoma City, OK 73125-0105  
U.S.A.

or telephone

country code 01  
(405) 324-5311

Ask for the Technical Services Manager. Unfortunately, we are unable to accept collect calls.

You can also contact us via FAX at (405) 324-8981 or Telex at 160369. Every effort will be made to provide prompt and reliable support.

## 8.0 FACTORY SERVICE

If factory service is required, prepare a note describing the problem in detail. Include any additional information which may be helpful such as test conditions, where used, etc. and ship the unit to:

Altec Lansing Customer  
Service/Repair  
10500 W. Reno  
Oklahoma City, OK 73128 U.S.A.

**NOTICE:** *Modifications to ALTEC LANSING products, except for those described herein, are not recommended. Such modifications shall be at the sole expense of the person(s) or company responsible, and any damage resulting therefrom shall not be covered under warranty or otherwise.*

---

## NOTES

*Operating Instructions for the 8553B Dual Channel Programmable MicroAudio Equalizer*

**APPENDIX - 8553B DEVICE ADDRESS CODES**

ADDRESS CODES	DIP SWITCH POSITIONS (FROM LEFT TO RIGHT)								ADDRESS CODES	DIP SWITCH POSITIONS (FROM LEFT TO RIGHT)							
	#1	#2	#3	#4	#5	#6	#7	#8		#1	#2	#3	#4	#5	#6	#7	#8
001	ON	ON	ON	ON	ON	ON	ON	OFF	065	ON	OFF	ON	ON	ON	ON	ON	OFF
002	ON	ON	ON	ON	ON	ON	OFF	ON	066	ON	OFF	ON	ON	ON	ON	OFF	ON
003	ON	ON	ON	ON	ON	ON	OFF	OFF	067	ON	OFF	ON	ON	ON	ON	OFF	OFF
004	ON	ON	ON	ON	ON	OFF	ON	ON	068	ON	OFF	ON	ON	ON	OFF	ON	ON
005	ON	ON	ON	ON	ON	OFF	ON	OFF	069	ON	OFF	ON	ON	ON	OFF	ON	OFF
006	ON	ON	ON	ON	ON	OFF	OFF	ON	070	ON	OFF	ON	ON	ON	OFF	OFF	ON
007	ON	ON	ON	ON	ON	OFF	OFF	OFF	071	ON	OFF	ON	ON	ON	OFF	OFF	OFF
008	ON	ON	ON	ON	OFF	ON	ON	ON	072	ON	OFF	ON	ON	OFF	ON	ON	ON
009	ON	ON	ON	ON	OFF	ON	ON	OFF	073	ON	OFF	ON	ON	OFF	ON	ON	OFF
010	ON	ON	ON	ON	OFF	ON	OFF	ON	074	ON	OFF	ON	ON	OFF	ON	OFF	ON
011	ON	ON	ON	ON	OFF	ON	OFF	OFF	075	ON	OFF	ON	ON	OFF	ON	OFF	OFF
012	ON	ON	ON	ON	OFF	OFF	ON	ON	076	ON	OFF	ON	ON	OFF	OFF	ON	ON
013	ON	ON	ON	ON	OFF	OFF	ON	OFF	077	ON	OFF	ON	ON	OFF	OFF	ON	OFF
014	ON	ON	ON	ON	OFF	OFF	OFF	ON	078	ON	OFF	ON	ON	OFF	OFF	OFF	ON
015	ON	ON	ON	ON	OFF	OFF	OFF	OFF	079	ON	OFF	ON	ON	OFF	OFF	OFF	OFF
016	ON	ON	ON	OFF	ON	ON	ON	ON	080	ON	OFF	ON	OFF	ON	ON	ON	ON
017	ON	ON	ON	OFF	ON	ON	ON	OFF	081	ON	OFF	ON	OFF	ON	ON	ON	OFF
018	ON	ON	ON	OFF	ON	ON	OFF	ON	082	ON	OFF	ON	OFF	ON	ON	OFF	ON
019	ON	ON	ON	OFF	ON	ON	OFF	OFF	083	ON	OFF	ON	OFF	ON	ON	OFF	OFF
020	ON	ON	ON	OFF	ON	OFF	ON	ON	084	ON	OFF	ON	OFF	ON	OFF	ON	ON
021	ON	ON	ON	OFF	ON	OFF	ON	OFF	085	ON	OFF	ON	OFF	ON	OFF	ON	OFF
022	ON	ON	ON	OFF	ON	OFF	OFF	ON	086	ON	OFF	ON	OFF	ON	OFF	OFF	ON
023	ON	ON	ON	OFF	ON	OFF	OFF	OFF	087	ON	OFF	ON	OFF	ON	OFF	OFF	OFF
024	ON	ON	ON	OFF	OFF	ON	ON	ON	088	ON	OFF	ON	OFF	OFF	ON	ON	ON
025	ON	ON	ON	OFF	OFF	ON	ON	OFF	089	ON	OFF	ON	OFF	OFF	ON	ON	OFF
026	ON	ON	ON	OFF	OFF	ON	OFF	ON	090	ON	OFF	ON	OFF	OFF	ON	OFF	ON
027	ON	ON	ON	OFF	OFF	ON	OFF	OFF	091	ON	OFF	ON	OFF	OFF	ON	OFF	OFF
028	ON	ON	ON	OFF	OFF	OFF	ON	ON	092	ON	OFF	ON	OFF	OFF	OFF	ON	ON
029	ON	ON	ON	OFF	OFF	OFF	ON	OFF	093	ON	OFF	ON	OFF	OFF	OFF	ON	OFF
030	ON	ON	ON	OFF	OFF	OFF	OFF	ON	094	ON	OFF	ON	OFF	OFF	OFF	OFF	ON
031	ON	ON	ON	OFF	OFF	OFF	OFF	OFF	095	ON	OFF	ON	OFF	OFF	OFF	OFF	OFF
032	ON	ON	OFF	ON	ON	ON	ON	ON	096	ON	OFF	OFF	ON	ON	ON	ON	ON
033	ON	ON	OFF	ON	ON	ON	ON	OFF	097	ON	OFF	OFF	ON	ON	ON	ON	OFF
034	ON	ON	OFF	ON	ON	ON	OFF	ON	098	ON	OFF	OFF	ON	ON	ON	OFF	ON
035	ON	ON	OFF	ON	ON	ON	OFF	OFF	099	ON	OFF	OFF	ON	ON	ON	OFF	OFF
036	ON	ON	OFF	ON	ON	OFF	ON	ON	100	ON	OFF	OFF	ON	ON	OFF	ON	ON
037	ON	ON	OFF	ON	ON	OFF	ON	OFF	101	ON	OFF	OFF	ON	ON	OFF	ON	OFF
038	ON	ON	OFF	ON	ON	OFF	OFF	ON	102	ON	OFF	OFF	ON	ON	OFF	OFF	ON
039	ON	ON	OFF	ON	ON	OFF	OFF	OFF	103	ON	OFF	OFF	ON	ON	OFF	OFF	OFF
040	ON	ON	OFF	ON	OFF	ON	ON	ON	104	ON	OFF	OFF	ON	OFF	ON	ON	ON
041	ON	ON	OFF	ON	OFF	ON	ON	OFF	105	ON	OFF	OFF	ON	OFF	ON	ON	OFF
042	ON	ON	OFF	ON	OFF	ON	OFF	ON	106	ON	OFF	OFF	ON	OFF	ON	OFF	ON
043	ON	ON	OFF	ON	OFF	ON	OFF	OFF	107	ON	OFF	OFF	ON	OFF	ON	OFF	OFF
044	ON	ON	OFF	ON	OFF	OFF	ON	ON	108	ON	OFF	OFF	ON	OFF	OFF	ON	ON
045	ON	ON	OFF	ON	OFF	OFF	ON	OFF	109	ON	OFF	OFF	ON	OFF	OFF	ON	OFF
046	ON	ON	OFF	ON	OFF	OFF	OFF	ON	110	ON	OFF	OFF	ON	OFF	OFF	OFF	ON
047	ON	ON	OFF	ON	OFF	OFF	OFF	OFF	111	ON	OFF	OFF	ON	OFF	OFF	OFF	OFF
048	ON	ON	OFF	OFF	ON	ON	ON	ON	112	ON	OFF	OFF	OFF	ON	ON	ON	ON
049	ON	ON	OFF	OFF	ON	ON	ON	OFF	113	ON	OFF	OFF	OFF	ON	ON	ON	OFF
050	ON	ON	OFF	OFF	ON	ON	OFF	ON	114	ON	OFF	OFF	OFF	ON	ON	OFF	ON
051	ON	ON	OFF	OFF	ON	ON	OFF	OFF	115	ON	OFF	OFF	OFF	ON	ON	OFF	OFF
052	ON	ON	OFF	OFF	ON	OFF	ON	ON	116	ON	OFF	OFF	OFF	ON	OFF	ON	ON
053	ON	ON	OFF	OFF	ON	OFF	ON	OFF	117	ON	OFF	OFF	OFF	ON	OFF	ON	OFF
054	ON	ON	OFF	OFF	ON	OFF	OFF	ON	118	ON	OFF	OFF	OFF	ON	OFF	OFF	ON
055	ON	ON	OFF	OFF	ON	OFF	OFF	OFF	119	ON	OFF	OFF	OFF	ON	OFF	OFF	OFF
056	ON	ON	OFF	OFF	OFF	ON	ON	ON	120	ON	OFF	OFF	OFF	OFF	ON	ON	ON
057	ON	ON	OFF	OFF	OFF	ON	ON	OFF	121	ON	OFF	OFF	OFF	OFF	ON	ON	OFF
058	ON	ON	OFF	OFF	OFF	ON	OFF	ON	122	ON	OFF	OFF	OFF	OFF	ON	OFF	ON
059	ON	ON	OFF	OFF	OFF	ON	OFF	OFF	123	ON	OFF	OFF	OFF	OFF	ON	OFF	OFF
060	ON	ON	OFF	OFF	OFF	OFF	ON	ON	124	ON	OFF	OFF	OFF	OFF	OFF	ON	ON
061	ON	ON	OFF	OFF	OFF	OFF	ON	OFF	125	ON	OFF	OFF	OFF	OFF	OFF	ON	OFF
062	ON	ON	OFF	OFF	OFF	OFF	OFF	ON	126	ON	OFF	OFF	OFF	OFF	OFF	OFF	ON
063	ON	ON	OFF	OFF	OFF	OFF	OFF	OFF	127	ON	OFF	OFF	OFF	OFF	OFF	OFF	OFF
064	ON	ON	OFF	ON	ON	ON	ON	ON	128	ON	OFF	OFF	ON	ON	ON	ON	ON

*Operating Instructions for the 8553B Dual Channel Programmable MicroAudio Equalizer*

ADDRESS CODES	DIP SWITCH POSITIONS (FROM LEFT TO RIGHT)								ADDRESS CODES	DIP SWITCH POSITIONS (FROM LEFT TO RIGHT)							
	#1	#2	#3	#4	#5	#6	#7	#8		#1	#2	#3	#4	#5	#6	#7	#8
129	OFF	ON	ON	ON	ON	ON	ON	OFF	193	OFF	OFF	ON	ON	ON	ON	ON	OFF
130	OFF	ON	ON	ON	ON	ON	OFF	ON	194	OFF	OFF	ON	ON	ON	ON	OFF	ON
131	OFF	ON	ON	ON	ON	ON	OFF	OFF	195	OFF	OFF	ON	ON	ON	ON	OFF	OFF
132	OFF	ON	ON	ON	ON	OFF	ON	ON	196	OFF	OFF	ON	ON	ON	OFF	ON	ON
133	OFF	ON	ON	ON	ON	OFF	ON	OFF	197	OFF	OFF	ON	ON	ON	OFF	ON	OFF
134	OFF	ON	ON	ON	ON	OFF	OFF	ON	198	OFF	OFF	ON	ON	ON	OFF	OFF	ON
135	OFF	ON	ON	ON	ON	OFF	OFF	OFF	199	OFF	OFF	ON	ON	ON	OFF	OFF	OFF
136	OFF	ON	ON	ON	OFF	ON	ON	ON	200	OFF	OFF	ON	ON	OFF	ON	ON	ON
137	OFF	ON	ON	ON	OFF	ON	ON	OFF	201	OFF	OFF	ON	ON	OFF	ON	ON	OFF
138	OFF	ON	ON	ON	OFF	ON	OFF	ON	202	OFF	OFF	ON	ON	OFF	ON	OFF	ON
139	OFF	ON	ON	ON	OFF	ON	OFF	OFF	203	OFF	OFF	ON	ON	OFF	ON	OFF	OFF
140	OFF	ON	ON	ON	OFF	OFF	ON	ON	204	OFF	OFF	ON	ON	OFF	OFF	ON	ON
141	OFF	ON	ON	ON	OFF	OFF	ON	OFF	205	OFF	OFF	ON	ON	OFF	OFF	ON	OFF
142	OFF	ON	ON	ON	OFF	OFF	OFF	ON	206	OFF	OFF	ON	ON	OFF	OFF	OFF	ON
143	OFF	ON	ON	ON	OFF	OFF	OFF	OFF	207	OFF	OFF	ON	ON	OFF	OFF	OFF	OFF
144	OFF	ON	ON	OFF	ON	ON	ON	ON	208	OFF	OFF	ON	OFF	ON	ON	ON	ON
145	OFF	ON	ON	OFF	ON	ON	ON	OFF	209	OFF	OFF	ON	OFF	ON	ON	ON	OFF
146	OFF	ON	ON	OFF	ON	ON	OFF	ON	210	OFF	OFF	ON	OFF	ON	ON	OFF	ON
147	OFF	ON	ON	OFF	ON	ON	OFF	OFF	211	OFF	OFF	ON	OFF	ON	ON	OFF	OFF
148	OFF	ON	ON	OFF	ON	OFF	ON	ON	212	OFF	OFF	ON	OFF	ON	ON	OFF	ON
149	OFF	ON	ON	OFF	ON	OFF	ON	OFF	213	OFF	OFF	ON	OFF	ON	OFF	ON	OFF
150	OFF	ON	ON	OFF	ON	OFF	OFF	ON	214	OFF	OFF	ON	OFF	ON	OFF	OFF	ON
151	OFF	ON	ON	OFF	ON	OFF	OFF	OFF	215	OFF	OFF	ON	OFF	ON	OFF	OFF	OFF
152	OFF	ON	ON	OFF	OFF	ON	ON	ON	216	OFF	OFF	ON	OFF	OFF	ON	ON	ON
153	OFF	ON	ON	OFF	OFF	ON	ON	OFF	217	OFF	OFF	ON	OFF	OFF	ON	ON	OFF
154	OFF	ON	ON	OFF	OFF	ON	OFF	ON	218	OFF	OFF	ON	OFF	OFF	ON	OFF	ON
155	OFF	ON	ON	OFF	OFF	ON	OFF	OFF	219	OFF	OFF	ON	OFF	OFF	ON	OFF	OFF
156	OFF	ON	ON	OFF	OFF	OFF	ON	ON	220	OFF	OFF	ON	OFF	OFF	OFF	ON	ON
157	OFF	ON	ON	OFF	OFF	OFF	ON	OFF	221	OFF	OFF	ON	OFF	OFF	OFF	ON	OFF
158	OFF	ON	ON	OFF	OFF	OFF	OFF	ON	222	OFF	OFF	ON	OFF	OFF	OFF	OFF	ON
159	OFF	ON	ON	OFF	OFF	OFF	OFF	OFF	223	OFF	OFF	ON	OFF	OFF	OFF	OFF	OFF
160	OFF	ON	OFF	ON	ON	ON	ON	ON	224	OFF	OFF	OFF	ON	ON	ON	ON	ON
161	OFF	ON	OFF	ON	ON	ON	ON	OFF	225	OFF	OFF	OFF	ON	ON	ON	ON	OFF
162	OFF	ON	OFF	ON	ON	ON	OFF	ON	226	OFF	OFF	OFF	ON	ON	ON	OFF	ON
163	OFF	ON	OFF	ON	ON	ON	OFF	OFF	227	OFF	OFF	OFF	ON	ON	ON	OFF	OFF
164	OFF	ON	OFF	ON	ON	OFF	ON	ON	228	OFF	OFF	OFF	ON	ON	ON	OFF	ON
165	OFF	ON	OFF	ON	ON	OFF	ON	OFF	229	OFF	OFF	OFF	ON	ON	OFF	ON	OFF
166	OFF	ON	OFF	ON	ON	OFF	OFF	ON	230	OFF	OFF	OFF	ON	ON	OFF	OFF	ON
167	OFF	ON	OFF	ON	ON	OFF	OFF	OFF	231	OFF	OFF	OFF	ON	ON	OFF	OFF	OFF
168	OFF	ON	OFF	ON	OFF	ON	ON	ON	232	OFF	OFF	OFF	ON	OFF	ON	ON	ON
169	OFF	ON	OFF	ON	OFF	ON	ON	OFF	233	OFF	OFF	OFF	ON	OFF	ON	ON	OFF
170	OFF	ON	OFF	ON	OFF	ON	OFF	ON	234	OFF	OFF	OFF	ON	OFF	ON	OFF	ON
171	OFF	ON	OFF	ON	OFF	ON	OFF	OFF	235	OFF	OFF	OFF	ON	OFF	ON	OFF	OFF
172	OFF	ON	OFF	ON	OFF	OFF	ON	ON	236	OFF	OFF	OFF	ON	OFF	OFF	ON	ON
173	OFF	ON	OFF	ON	OFF	OFF	ON	OFF	237	OFF	OFF	OFF	ON	OFF	OFF	ON	OFF
174	OFF	ON	OFF	ON	OFF	OFF	OFF	ON	238	OFF	OFF	OFF	ON	OFF	OFF	OFF	ON
175	OFF	ON	OFF	ON	OFF	OFF	OFF	OFF	239	OFF	OFF	OFF	ON	OFF	OFF	OFF	OFF
176	OFF	ON	OFF	OFF	ON	ON	ON	ON	240	OFF	OFF	OFF	OFF	ON	ON	ON	ON
177	OFF	ON	OFF	OFF	ON	ON	ON	OFF	241	OFF	OFF	OFF	OFF	ON	ON	ON	OFF
178	OFF	ON	OFF	OFF	ON	ON	OFF	ON	242	OFF	OFF	OFF	OFF	ON	ON	OFF	ON
179	OFF	ON	OFF	OFF	ON	ON	OFF	OFF	243	OFF	OFF	OFF	OFF	ON	ON	OFF	OFF
180	OFF	ON	OFF	OFF	ON	OFF	ON	ON	244	OFF	OFF	OFF	OFF	ON	ON	OFF	ON
181	OFF	ON	OFF	OFF	ON	OFF	ON	OFF	245	OFF	OFF	OFF	OFF	ON	OFF	ON	OFF
182	OFF	ON	OFF	OFF	ON	OFF	OFF	ON	246	OFF	OFF	OFF	OFF	ON	OFF	OFF	ON
183	OFF	ON	OFF	OFF	ON	OFF	OFF	OFF	247	OFF	OFF	OFF	OFF	ON	OFF	OFF	OFF
184	OFF	ON	OFF	OFF	OFF	ON	ON	ON	248	OFF	OFF	OFF	OFF	OFF	ON	ON	ON
185	OFF	ON	OFF	OFF	OFF	ON	ON	OFF	249	OFF	OFF	OFF	OFF	OFF	ON	ON	OFF
186	OFF	ON	OFF	OFF	OFF	ON	OFF	ON	250	OFF	OFF	OFF	OFF	OFF	ON	OFF	ON
187	OFF	ON	OFF	OFF	OFF	ON	OFF	OFF									
188	OFF	ON	OFF	OFF	OFF	OFF	ON	ON									
189	OFF	ON	OFF	OFF	OFF	OFF	ON	OFF									
190	OFF	ON	OFF	OFF	OFF	OFF	OFF	ON									
191	OFF	ON	OFF	OFF	OFF	OFF	OFF	OFF									
192	OFF	ON	OFF	ON	ON	ON	ON	ON									