

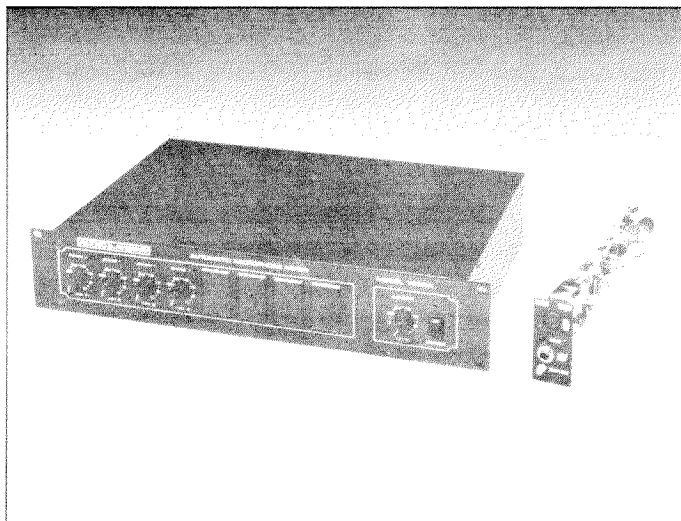

# 1684A Expandable Automatic Microphone Mixer



## KEY FEATURES

- ★ **Two Modes of Operation.**
- ★ **Easy Setup with One Control.**
- ★ **User Expandable with 1681A Input Modules.**
- ★ **NOM=1 Function Automatically Adjusts from 0 dB to 20 log NOM dB.**

## PRIMARY SPECIFICATIONS

<b>Frequency Response:</b>	50 Hz - 20 kHz +1, -2 dB
<b>Total Harmonic Distortion:</b>	< 0.20%, +4 dBm at main output, 50 Hz to 20 kHz (channel controls at 12 o'clock, master nominal)
<b>Noise:</b>	(150 ohm source, 20 Hz - 20 kHz BW)
<b>Equivalent Input Noise:</b>	-124 dBm
<b>Output Noise:</b>	(channel controls full counterclockwise):
<b>Master full counterclockwise:</b>	-86 dBm
<b>Master nominal:</b>	-85 dBm
<b>Output Noise:</b>	(channel controls at 12 o'clock)
<b>Master nominal:</b>	-82 dBm
<b>High-Pass Filter:</b>	200 Hz, 6 dB/octave
<b>Maximum Input Level:</b>	
<b>Channel Input (Mic):</b>	-30 dBu
<b>Channel Input (Line):</b>	+23 dBu
<b>Premix Input:</b>	+23 dBu
<b>Mix Input:</b>	+23 dBu
<b>Channel Gain Control Range:</b>	26 - 54 dB (mic only)

Registered U.S. Patent No. 3,992,584

## DESCRIPTION

The ALTEC LANSING® **1684A** Automatic Microphone Mixer is a rack-mountable, four-channel mixer that is designed for commercial sound reinforcement. It can be expanded up to eight channels by adding individual **1681A** input modules. Each input channel exhibits balanced mic or line input with phantom power for condenser microphones, variable input pre-amp gain control, line output for logging recorders, logic output, high pass filter, phantom power, automatic or manual operating modes, and a channel status LED. The status LED not only displays the status of the input channel, but also gives a relative indication of the channel's gain. The master section features a remote volume control, priority/mute system, and series/parallel link capabilities. By utilizing the linking, multiple units may be com-

bined in either series or parallel configurations to establish conference systems of any size. For the series-combined configuration, one mixer in the system operates as the master, and the remaining mixers as extensions of the master. For the parallel-combined configuration, any mixer in the system may operate as the master. The maximum recommended number of automatically mixed channels for each series-combined or parallel-combined system is forty. The **1684A** link system topology is similar to earlier models for compatibility with existing ALTEC LANSING sound installations.

The **1684A** maintains the patented Dugan speech system, with an additional "live" mode of operation. In the "live" mode, an individual channel does not attenuate during speech pauses like most other automatic mixers. The "live" mode

## DESCRIPTION (continued)

allows the system to sound natural with the clarity of a manual mixer controlled by a human operator. This gives the system the live sound of room ambience without the audible gating of microphone channels. A "muting" mode of operation is available for those installations where channel attenuation is necessary. The patented circuitry allows easy system setup with only one front panel volume control for each channel. It also adjusts the NOM=1 function from 0 dB to 20 log NOM dB automatically without any manual setup.

The packaging of the **1684A** is distinctive. The standard unit comes from the factory with four

channels installed. It is expandable up to eight channels with the addition of up to four **1681A** automatic input modules, each sold separately. This packaging approach allows the contractor to tailor the **1684A** to each installation. Each **1681A** can be easily inserted by removing the top panel, sliding the input card into the card guide, and connecting the bus cable. This greatly simplifies future system expansion.

The ALTEC LANSING **1684A** Automatic Microphone Mixer's increased performance and flexibility meets the expanding mixing needs of the ever-changing commercial audio industry.

## SPECIFICATIONS (continued)

### Measurement Conditions

1. 120 Vrms, 60 Hz line voltage maintained throughout testing.
2. 0 dBu = 0.775 Vrms.

### Maximum Voltage Gain:

Channel Input (Mic) to Line Output:	54 dB
Channel Input (Line) to Line Output:	0 dB
Channel Input to Premix Output:	75 dB
Channel Input to Mix Output:	78 dB
Channel Input to Main Output:	83 dB
Premix Input to Premix Output:	0 dB
Mix Input to Mix Output:	0 dB
Mix Input to Main Output:	14 dB

### Minimum Load Impedance:

Main Output:	600 ohms
Line Output:	10K ohms
Premix Output:	10K ohms
Mix Output:	10K ohms

### Maximum Output Level:

Main Output:	+21 dBm
Line Output:	+23 dBu
Premix Output:	+23 dBu
Mix Output:	+23 dBu

**Phantom Power Voltage:** +18 Vdc

### Dimensions:

Height:	3.5 inches (8.9 cm)
Width:	19 inches (48.3 cm)
Depth:	12 inches (30.5 cm)

**Weight:** 14 lbs (5.5 kg)

**Power Requirements:** 115/230 Vrms (switchable), 20 W

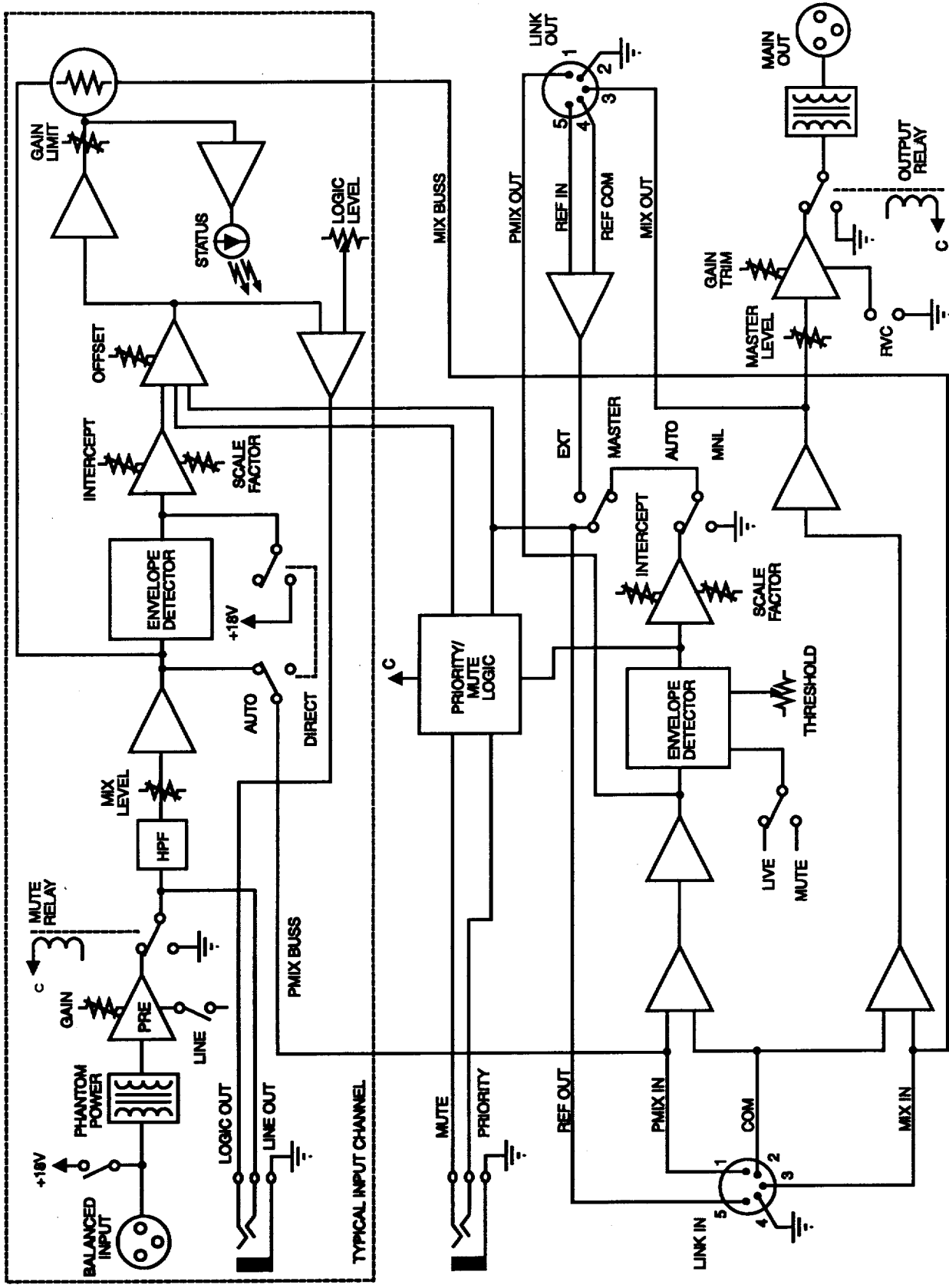

System Block Diagram

## ARCHITECT'S and ENGINEER'S SPECIFICATION

The automatic microphone mixer shall contain four input channels and be rack-mountable. It shall be constructed so that it can be expanded up to eight input channels by adding individual input modules. Each input channel shall have a balanced mic or line input with switchable phantom power for condenser microphones, variable input pre-amp gain control, line output for logging recorders, logic output, high pass filter, phantom power, automatic or manual operating modes, and a channel status LED. The status LED shall not only show channel status but also give relative indication of the channel's gain. The master section shall have a remote volume control, a priority/mute system and series/parallel link capabilities. The automatic microphone mixer's linking topology shall be similar to earlier models for compatibility with existing sound installations. The unit shall exhibit two modes of automatic operation. In the "live" mode, the system shall sound natural with the clarity of a manual mixer without microphone channel gating. The "mute" mode shall allow for individual microphone attenuation. The mixer shall adjust

the NOM=1 function from 0 dB to 20 log NOM dB automatically without manual setup.

The mixer shall meet the following performance criteria. Frequency response: 20 Hz to 20 kHz, +1, -2 dB. THD: < 0.20% at +4 dBm at main output, 20 Hz to 20 kHz, with channel controls at 12 o'clock and master at nominal. Equivalent input noise: -124 dBm with 150 ohm source, 20 Hz to 20 kHz BW. Output noise: -86 dBm with channel and master controls full counterclockwise. Output noise: -85 dBm with channel controls full counterclockwise and master control at nominal, 20 Hz - 20 kHz BW. Output noise: -82 dBm with channel controls at 12 o'clock and master control at nominal, 20 Hz - 20 kHz BW. Maximum channel input (mic) level: -30 dBu. Maximum channel input (line) level: +23 dBu. The dimensions shall be: Height: 3.5 inches (8.9 cm); Width: 19 inches (48.3 cm); Depth: 12 inches (30.5 cm); Weight: 14 lbs (5.5 kg).

The automatic microphone mixer shall be the ALTEC LANSING 1684A. The individual input module shall be the ALTEC LANSING 1681A.



a MARK IV company

P.O. BOX 26105 ● OKLAHOMA CITY, OK 73126-0105 ● U.S.A. ● (405) 324-5311 or FAX: (405) 324-8981  
© 1993 ALTEC LANSING CORPORATION



*the sound of experience.*

# 1684A

## Automatic Microphone Mixer

# Operating and Service Instructions



**ALTEC LANSING CORPORATION**

a MARK IV company

P.O. Box 26105 • Oklahoma City, OK • 73126-0105 USA • Tel: (405) 324-5311 • FAX: (405) 324-8981

---

# Table of Contents

1	INSTALLATION .....	1
1.1	Rack Mounting .....	1
1.2	Ventilation .....	1
2	SIGNAL CONNECTIONS .....	1
2.1	Input Connections .....	1
2.2	Output Connections .....	1
2.3	Multiple Connections .....	1
2.3.1	Series Configuration .....	1
2.3.2	Parallel Configuration .....	2
3	FEATURES .....	2
3.1	Front Panel Features .....	2
3.2	Rear Panel Features .....	2
3.3	Internal Features .....	4
4	OPERATION .....	4
4.1	Setting Up The 1684A .....	4
4.2	Priority Function .....	5
4.3	Suppression of Ambient Noise .....	5
4.3.1	Suppressing Ambient Noise with the MUTE mode .....	5
4.3.2	Suppressing Ambient Noise with the Dummy Mike Technique .....	5
4.3.2.1	Dummy Mike Setup For MUTE Mode .....	5
4.3.2.2	Type and Placement of the Dummy Mike .....	6
4.3.2.3	Mixer Adjustment .....	6
4.4	Installation of Additional 1681A Input Modules .....	6
5	SYSTEM SPECIFICATIONS .....	7
6	SERVICE INFORMATION .....	9
6.1	Parts Ordering .....	9
6.2	Factory Service .....	9
6.3	Technical Assistance .....	9
6.4	Electrical .....	9
6.4.1	115 Vac 50/60 Hz Operation .....	9
6.4.2	230 Vac 50/60 Hz Operation .....	9
6.5	Linking Into Existing Systems .....	9
6.6	Master/Power Supply Alignment Procedure .....	9
6.7	Input Module Alignment Procedure .....	10
	System Block Diagram .....	7
	1684A Assembly Drawing .....	12
	Input Module Schematic .....	13
	Master/Power Supply Board Schematic .....	14
	Parallel Linking Interface .....	16

## 1 INSTALLATION

### 1.1 Rack Mounting

The mixer may be installed in a standard 19-inch equipment rack. It requires 3.50 inches of vertical space (2 standard EIA rack spaces). Mounting is accomplished by using the hardware supplied.

### 1.2 Ventilation

The mixer should not be used in areas where the ambient temperature exceeds 60° C (140° F).

## 2 SIGNAL CONNECTIONS

### 2.1 Input Connections

Balanced microphone or high-level line inputs may be made to the 3-pin XLR-type connectors on the rear of the chassis. A positive voltage on pin 2 (with respect to pin 3) produces a positive voltage on pin 2 of the MAIN output connector and on the tip of the channel line output ¼-inch connector. For single-ended inputs, strap the low (-) input (pin 3) to ground. Refer to Figure 1 for typical input connections.

### 2.2 Output Connections

The MAIN output of the mixer is transformer-isolated. A balanced output connection may be made to the male 3-pin XLR-type connector on the rear of the chassis. For a single-ended output, strap the low (-) output (pin 3) to ground. Each individual channel has a preamp direct output that is unaffected by any

automatic mixing function. It is available at the tip of the LINE OUT connector. A channel logic output is available at the ring of the LINE OUT connector. Refer to Figure 2 for typical output connections.

### 2.3 Multiple Connections

Mixers may be linked to establish large conferencing systems in a series or parallel configuration. Units are shipped from the factory in the series configuration. The 1684A may be linked in existing systems with earlier models of ALTEC LANSING automatic microphone mixers. Refer to Section 6.5 of this manual for linking in existing systems.

#### 2.3.1 Series Configuration

For systems that require one mixer output and more automatic microphone inputs than are available in one unit, connect multiple mixers together referring to Figure 3. In Figure 3 mixer #1 is set in the master mode and the others in the extension mode. All system inputs are mixed together and the mix is present on the master's main output. Only one mixer in this system can operate as the master. All master level controls on the extension units are inoperable.

Five-way shielded cable with male and female 5-pin XLR-type connectors are used to link each mixer into the system. Refer to Figure 5 for the proper link cable assembly. The LINK IN connector of the first mixer is connected to the LINK OUT connector of the second mixer. This method of interconnection is continued for the remaining mixers. Note that the shield

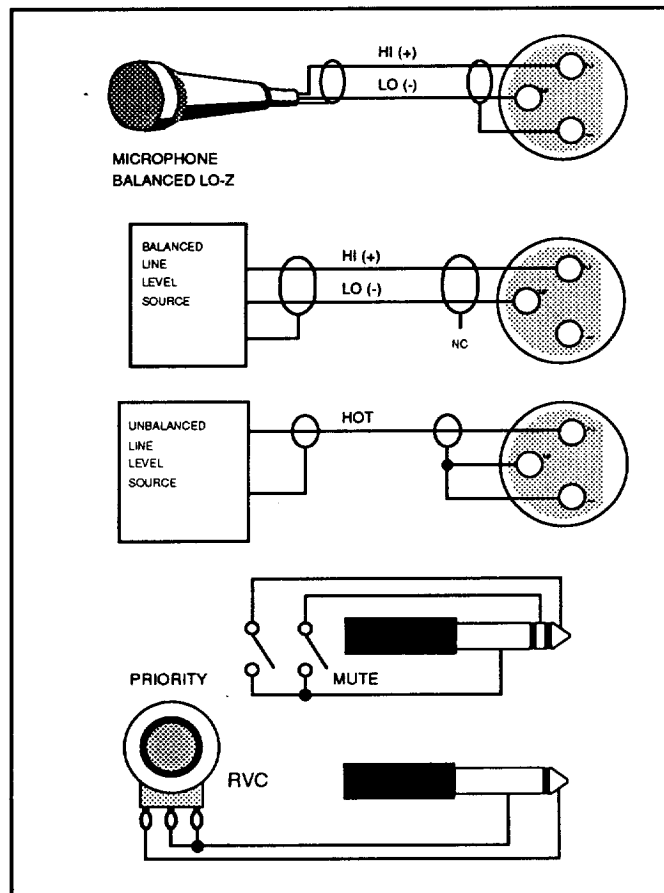

Figure 1: Typical Input Connections.

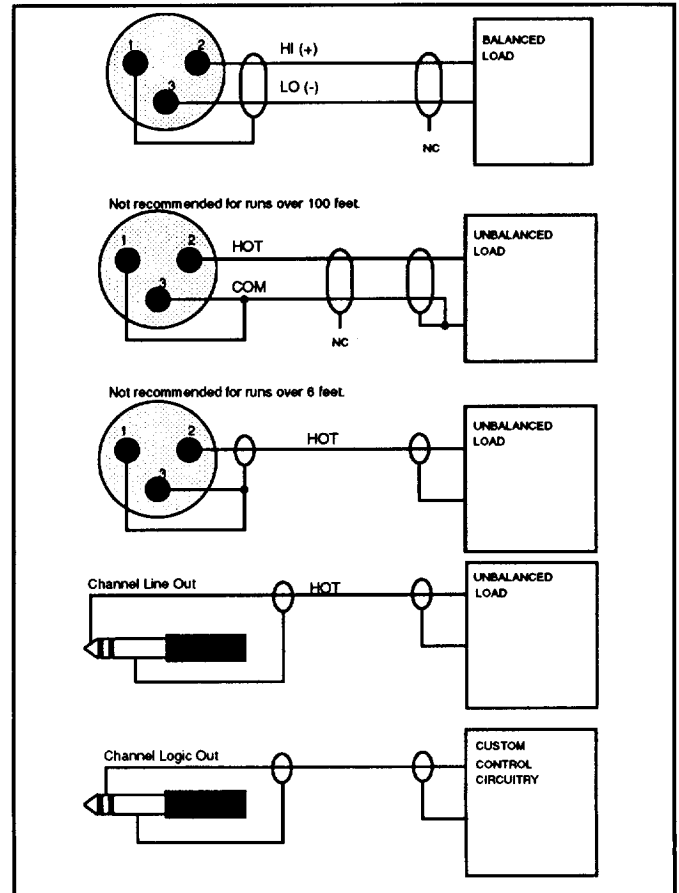

Figure 2: Typical Output Connections.

is connected *only* to the LINK OUT connector.

**NOTE:** Series and parallel configurations may not be used within the same linking system.

### 2.3.2 Parallel Configuration

For systems that require multiple mixer outputs and more automatic microphone inputs than are available in one unit, connect multiple mixers together referring to Figure 4. In the parallel configuration all mixers are set in the master mode. All system inputs are mixed together and the mix is present on all main outputs. Do not configure a parallel linked system for more than five mixers or use linking cable longer than six feet without additional isolation/noise control due to the low signal levels involved. Refer to Figure 5 for the proper link cable assembly. Parallel configurations require construction of an interface described in the Service Instructions. Construction of the interface is somewhat complex and requires interactive parameters affecting the operation be strictly controlled. ALTEC LANSING does not warranty user-built equipment, nor that ALTEC LANSING products will function properly with user-built equipment. Accordingly, it is recommended that appropriate ALTEC LANSING contractors be consulted before attempting construction of the interface. Before connecting each mixer to the interface, an internal connector must be relocated on the Master PC board. Refer to Figure 4 to make this change.

## 3 FEATURES

### 3.1 Front Panel Features (Refer to Figure 6)

1. **Status LEDs:** The status LED illumination indicates the relative gain status of the individual channel.
2. **Channel Level Controls:** These controls adjust the signal level of the corresponding channels prior to the mix buss.
3. **Maestro Covers:** These covers are to be removed when additional 1681A input modules are inserted. See Section 4.4 for 1681A installation instructions.
4. **Master Level Control:** This control adjusts the level of the main output signal.
5. **Power Switch:** The power switch is used to turn the main AC power on and off. The power LED illuminates when the power is on.

### 3.2 Rear Panel Features (Refer to Figure 7.)

1. **Priority/Mute Connector:** Connects an external switch to provide priority for Channel 1. While Channel 1 is switched to priority, all other channels are fully attenuated. See Section 4.2 of this manual for further information. Mute removes the signal from all line and main outputs in the mixer. See Figure 1 for typical connections of both priority and mute functions.

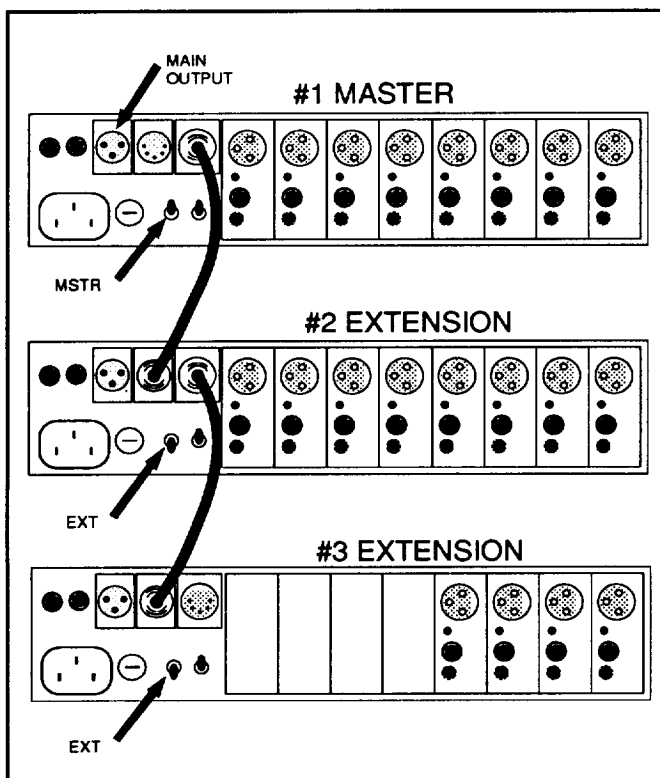

Figure 3: Series Linked Mixer Configuration.

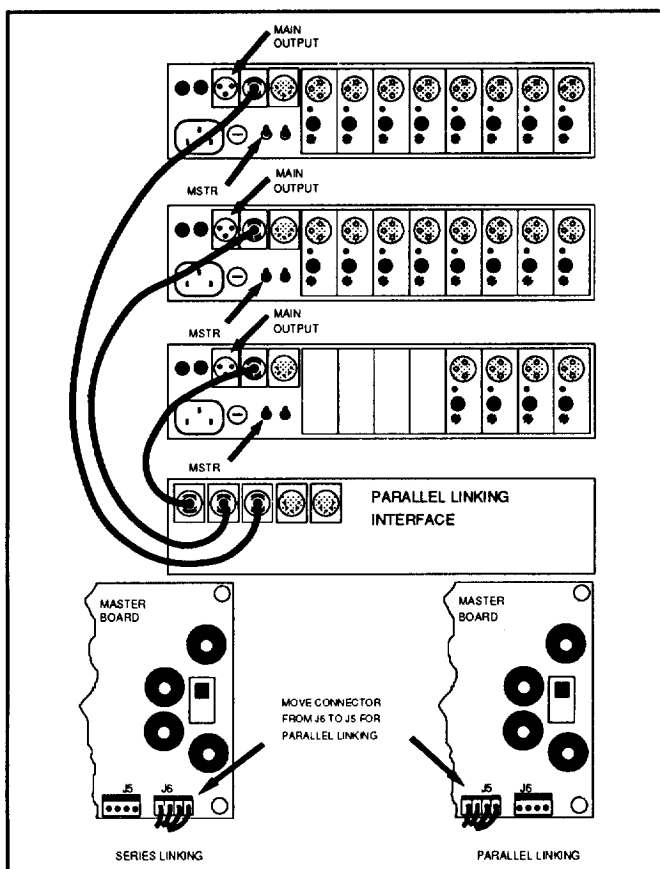

Figure 4: Parallel Linked Mixer Configuration.



2. **Remote Volume Control (RVC) Connector:** The RVC allows the master level to be adjusted from great distances from the mixer, since only DC voltages are present at this connection. The resistance of a potentiometer determines the amount of attenuation in the master voltage-controlled amplifier (VCA). To implement a remote volume control, connect an audio taper potentiometer (1 kohm or greater) between the tip and sleeve of a mono ¼-inch plug. Refer to Figure 1 for a typical connection.
3. **MAIN OUTPUT Connector:** The male 3-pin XLR-type connector provides connection to input of subsequent line level equipment rated at 600 ohms or higher input impedance.
4. **LINK OUT Connector:** The male 5-pin XLR-type connector provides connection to the LINK IN connector of another 1684A when two or more 1684A mixers are series linked to provide for additional inputs channels. Refer to Figure 3 and Section 2.3.1 of this manual. In a parallel linked system, this connector provides connection to the interface unit. Refer to Figure 4 and Section 2.3.2 of this manual.
5. **LINK IN Connector:** The female 5-pin XLR-type connector provides connection to the LINK OUT connector of another 1684A when two or more 1684A mixers are series linked to provide for additional input channels. Refer to Figure 3 and Section 2.3.1 of this manual. In a parallel linked system, this connector is not used. Refer to Figure 4 and Section 2.3.2 of this manual.
6. **Channel GAIN Control:** This control adjusts the gain of the microphone input preamplifier when the channel is in MIC mode. It has no effect when the channel is in LINE mode.
7. **Channel Input Connector:** This female 3-pin XLR-type connector provides for either microphone or line level input signals to each individual channel.
8. **AC Line Input Connector:** This connector provides the mixer with AC power via the detachable power cord.
9. **Fuse:** This fuse provides protection from excessive input current from the AC line.
10. **Master/Extension Switch:** This switch selects master or extension mode of operation for 1684A mixers in a series linked configuration. The master 1684A mixer controls the output level of the combined system. Only one 1684A in a series linked system may operate in the master mode; the remaining 1684A mixers must be switched to extension mode. See Figure 3. For parallel linked systems, all 1684A mixers should be in the master mode.
11. **Automatic/Manual Switch:** This switch selects either automatic or manual gain control for the entire mixer. It overrides individual channel AUTO/DIR switches.

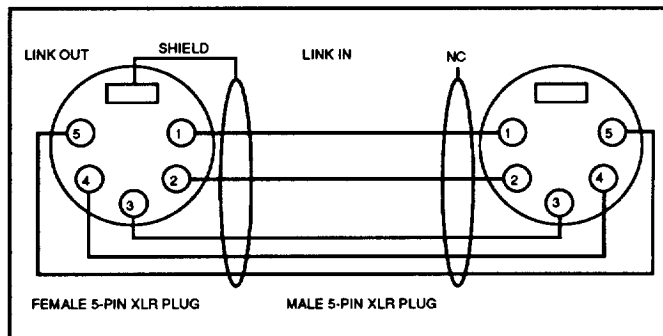

Figure 5: Link Cable Assembly.

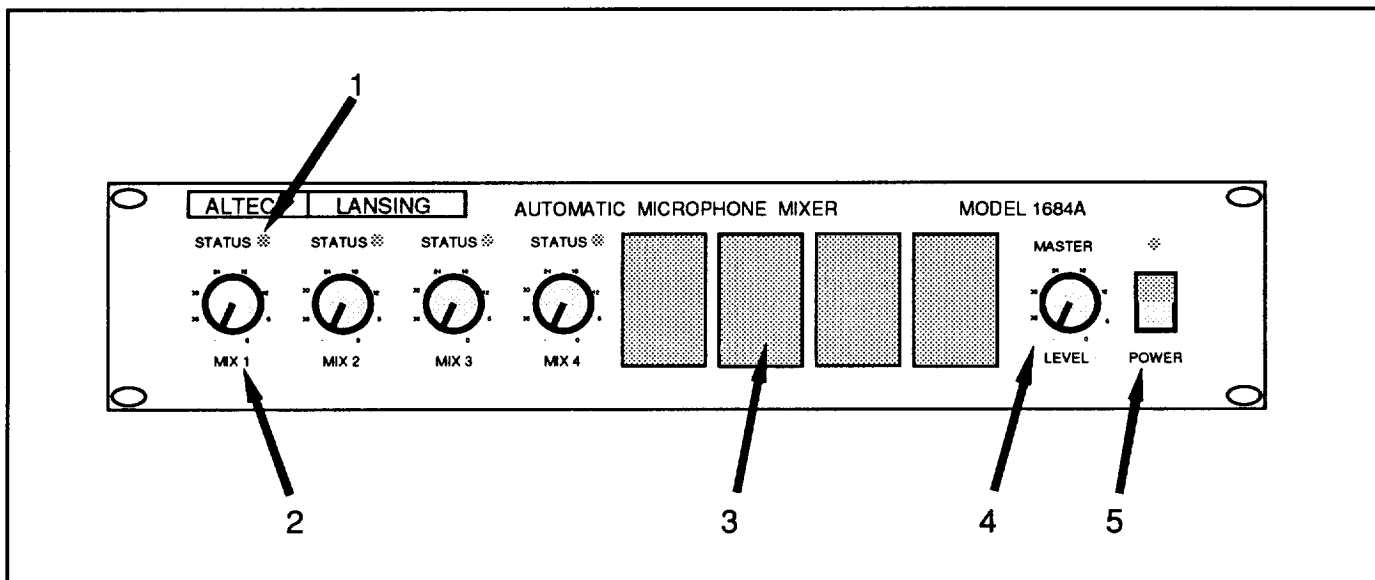

Figure 6: Front Panel Features.

12. **Blank Panels:** Removing these panels allow insertion of additional 1681A input modules.
13. **Line Out Connector:** The individual channel preamplifier output signal is present on the tip of this ¼-inch jack. Positive TTL logic output is provided on the ring. The logic output is high when the channel VCA is attenuated less than 3 dB. Where logic outputs are used in systems having four or less inputs, the dummy mike technique is recommended. See Section 4.3.2.
14. **Mic/Line Switch:** When this switch is in the *out* position, the channel accepts microphone level input signals. When it is in the *in* position, the channel can accept line level input signals.

### 3.3 Internal Features (Refer to Figure 8)

1. **Phantom Power Switch:** This switch on each input module provides +18 volts for powering condenser microphones.
2. **Input Module Mode Switch:** This switch selects either automatic mixing or direct mixing. In the automatic mode, the channel VCA controls the channel signal level for automatic mixing. In the direct mode, the channel VCA does not attenuate, allowing for a direct mix for the channel.
3. **High Pass Filter Switch:** This switch places a 200 Hz 6 dB/octave high pass filter in the signal path on the input channel.
4. **Voltage Select Switch:** This switch selects the AC line voltage for mixer operation.
5. **Mixer Mode Switch:** This switch selects the operating mode of automatic mixing. In the LIVE mode, all channels contribute to the automatic mix function regardless of the microphone activity. All

inputs are on at a lower gain which always adds up to the sound of one open microphone. In the MUTE mode, channels having audio levels below a fixed threshold (-39 dBu at the premix output) are attenuated.

## 4 OPERATION

### 4.1 Setting Up The 1684A

1. Remove the top panel and set the internal controls to the desired positions. Refer to Section 3.3 and Figure 8 of this manual for explanation of these controls.
2. Make all microphone and/or line input, linking, and output connections to mixer.
3. Turn down the system power amp. Set all input channel Gain controls on rear panel fully clockwise.
4. Set the Master level control and all automatic input channel level controls at the 2 o'clock position. If any input channels have the Auto/Direct switch in the Direct position, leave those level controls fully counterclockwise for this part of the setup.
5. With someone speaking into Mic 1, slowly adjust the power amp level control until ringing occurs then back off the control until ringing disappears.
6. Listen to the usual talkers and adjust the 1684A channel level controls of louder ones downward for the desired balance. If any input channel is clipping, reduce the GAIN controls.

This setup procedure sets each input channel at its maximum gain before feedback and assures that feedback will not occur whether one microphone or many microphones are being used. *Mix levels should not be increased from positions set in this manner.*

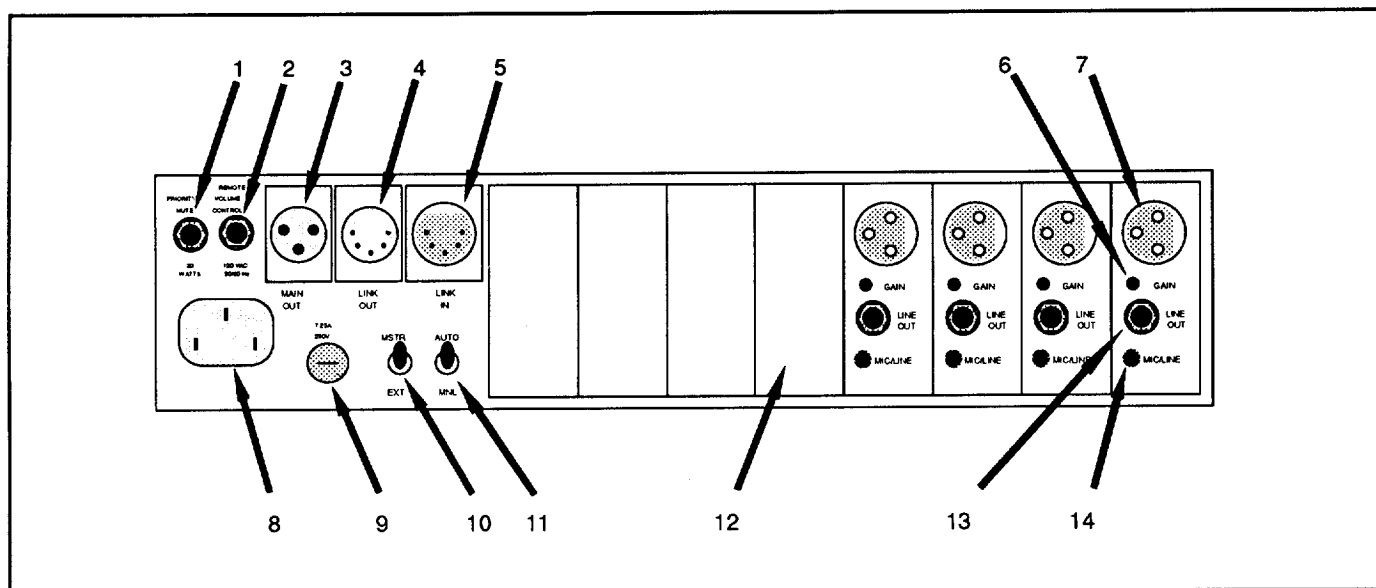

Figure 7: Rear Panel Features.

They can, of course be decreased. Thus, using these levels as starting points, decrease the level as needed to compensate for different talkers at different distances from the microphones. Final Mix levels will usually be somewhere between the "32" (9 o'clock) and "8" (3 o'clock) positions. If desired, the Master level may be decreased to allow the Mix levels to remain within this range. An increase in the Master control setting may require individual Mix settings to be re-adjusted again to avoid feedback or ringing.

#### 4.2 Priority Function

The priority function may be provided for any channel. The 1684A is shipped from the factory with Channel 1 set as the priority channel. When the external priority switch is open, all channels operate as normal. When the external priority switch is closed, Channel 1 operates normally while the remaining channels are fully attenuated. See Figure 1 for a typical switch connection. The priority function can be placed on any number of channels by placing a 10 kohm resistor in R37 on the appropriate input module(s). This resistor location is near the OFFSET adjustment control.

**Note:** If multiple channels are set for priority, they will not be automatically mixed.

#### 4.3 Suppression of Ambient Noise

In the LIVE operating mode, the 1684A provides a constant ambient noise pickup which sounds natural and is suitable for reinforcement, broadcasting, or recording. The 1684A offers two optional operating modes for suppressing ambient noise where soft-gating out of noise is desired. The trade-off that comes with turning down noise is the return of the noise when a mike is in use. This noise pumping or breathing sound effect is usually not desirable in broadcasting or recording, but may be inaudible in reinforcement where the ambience in the listeners' area masks the changes in ambience in the output of the sound system.

##### 4.3.1 Suppressing Ambient Noise with the MUTE mode

A simple method for suppressing ambient noise is provided by the use of the internal Mixer Mode Switch in the MUTE mode. When the switch is in this position each channel will act as an independent soft 2:1 expander gate below a fixed threshold. When sound levels are above the threshold, the mixer will maintain 1-mike system gain in exactly the same way as in the LIVE mode. The only difference between LIVE and MUTE modes is that low-level sound is turned down in the MUTE mode. The method can be successful where the ambient noise is fairly constant, and the voices close-miked.

The advantage of this mode is that it is simple to set up. The disadvantage is that the threshold is fixed and does not adapt the changing noise conditions. During applause or music all the mikes may open. The mixer can be adjusted for a higher threshold by lowering the input controls and the raising master. Be careful not to set the thresholds so high that the soft speech when the room is quiet is unable to open the channel fully. In any case, the automatic

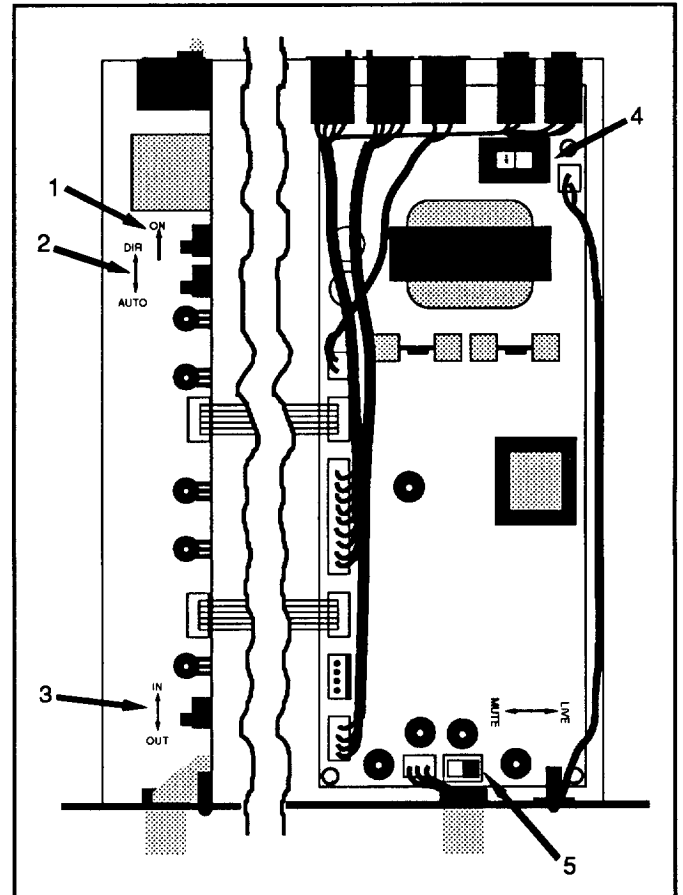

Figure 8: Internal Features.

mixing action will maintain 1-mike system gain no matter how many channels are activated.

##### 4.3.2 Suppressing Ambient Noise with the Dummy Mike Technique

Ambient noise can be suppressed with an intelligent, adaptive threshold, by the use of an ambience sensing mike in one mixer input, and modification of the mixer to remove that mike from the mix. This will provide a soft 2:1 expander gate on each channel below the ambient noise level. The threshold will automatically adjust to the ambient noise conditions. The dummy mike technique is recommended when the logic outputs are being used to switch speakers or cameras with less than four mikes in the system.

**NOTE:** This approach should not be used when the 1684A is operated in the LIVE mode.

###### 4.3.2.1 Dummy Mike Setup For MUTE Mode

1. Select the channel for the dummy mike.
2. Remove that input module from the chassis and locate R32 and RT1. Refer to Figure 9. Remove that channel from the audio mix by cutting either lead of both R32 and RT1. Do not cut the lead of the LED portion of RT1.

3. Replace the modified input module in the chassis.
4. Set all microphone channels and the modified channel to Auto. Set the High Pass filter on the modified channel to the same position as the normal channels (in most cases, this will be the IN position). Other 1684A mixers may be linked in the normal manner.

#### 4.3.2.2 Type and Placement of the *Dummy Mike*

Use the same type of microphone as the voice microphones or a good quality omnidirectional microphone with similar characteristics as the other microphones in the system. Imagine you are doing an old-time radio broadcast, with only one microphone, and position the *dummy mike* to pick up the general ambience in the room. Do not place the *dummy mike* near a particular system noise source, a loudspeaker, or one of the normal system microphones.

#### 4.3.2.3 Mixer Adjustment

1. With the front panel Mix and the rear panel Gain controls for the *dummy mike* channel fully counterclockwise, set the remaining channels as desired. See Section 4.1.
2. Feed low level pink noise into the sound system through a line level input.
3. Next, set the front panel Mix control on the *dummy mike* channel at 12 o'clock and adjust the Gain control until the Status LEDs on the normal channels begin to dim.
4. Turn off the pink noise and test the system microphone. If the *dummy mike* channel is turned up too far, the system microphones may sound compressed. If so, reduce the level of the *dummy mike* channel. If the system is too noisy when none of the system microphones are in use, the *dummy mike* channel level may need to be increased.

#### 4.4 Installation of Additional 1681A Input Modules

1. Remove the top cover of the 1684A by removing the screw on each side. Disconnect the two buss cables from the top of the installed input modules.
2. Remove the appropriate blank panel on the rear of the 1684A. Retain these two screws.
3. Remove the appropriate Maestro cover on the front of the 1684A.
4. Remove the knob, hex nut, and flat washer from the potentiometer on the 1681A input module.
5. Slide the 1681A with the header connectors up into the rear of the chassis ensuring that the bottom edge is firmly inserted into the card-edge guide. Continue sliding forward until the potentiometer and LED are seated in the front panel.
6. Replace the rear panel screws. Install the flat

washer onto the potentiometer shaft followed by the hex nut. Tighten the nut firmly.

7. Turn the potentiometer shaft fully counterclockwise. Push the knob onto the shaft lining up the knob marker with the  $-\infty$ .
8. Plug the buss cables onto the header connectors of each input module. Replace the top cover.

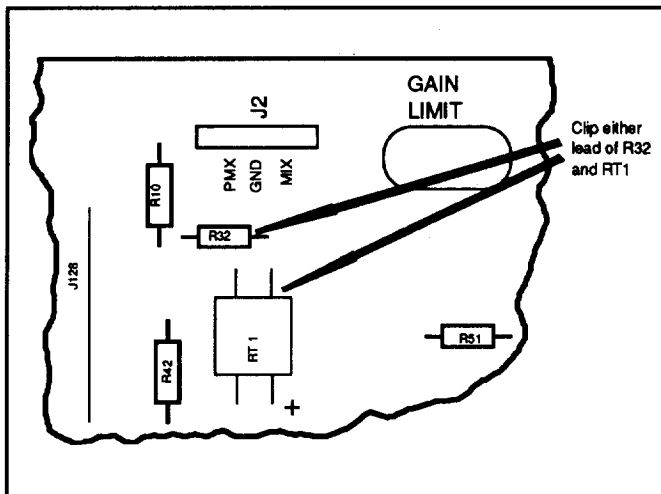

Figure 9: *Dummy Mic* Modification on Input Module.

**5 SYSTEM SPECIFICATIONS**

**Conditions:**

1. 120 Vrms, 60 Hz line voltage maintained throughout testing.
2. 0 dBu = 0.775 Vrms

**Frequency Response:** 50 Hz to 20 kHz +1, -2 dB

**THD:** < 0.20%  
(+4 dBm at main output, 50 Hz to 20 kHz with channel controls at 12 o'clock, master nominal)

**Noise:**  
(150 ohm source, 20 Hz to 20 kHz BW)

- Equivalent Input Noise: -124 dBm
- Output Noise (channel controls fully CCW): -86 dBm
- Master fully CCW: -85 dBm
- Master nominal: -85 dBm
- Channels at 12 o'clock, Master nom: -82 dBm

**High-Pass Filter:** 200 Hz, 6 dB/oct

**Maximum Voltage Gain:**

- Channel Input (Mic) to Line Output: 54 dB
- Channel Input (Line) to Line Output: 0 dB
- Channel Input to Premix Output: 75 dB
- Channel Input to Mix Output: 78 dB
- Channel Input to Main Output: 83 dB
- Premix Input to Premix Output: 0 dB
- Mix Input to Mix Output: 0 dB
- Mix Input to Main Output: 14 dB

**Channel GAIN Control Range:** 26 to 54 dB (Mic only)

**Maximum Input Level:**

- Channel Input (Mic): -30 dBu
- Channel Input (Line): +23 dBu
- Premix Input: +23 dBu
- Mix Input: +23 dBu

**Minimum Load Impedance:**

- Main Output: 600 ohms
- Line Output: 2K ohms
- Premix Output: 2K ohms
- Mix Output: 2K ohms

**Maximum Output Level:**

- Main Output: +21 dBm
- Line Output: +23 dBu
- Premix Output: +23 dBu
- Mix Output: +23 dBu

**Phantom Power Voltage:** +18 Vdc

**Dimensions:**

- Height: 3.5 inches (8.9 cm)
- Width: 19 inches (48.3 cm)
- Depth: 12 inches (30.5 cm)

**Weight:**

14 lbs (5.5 kgs)

**Power Requirements:**

115 or 230 Vrms, 20 W

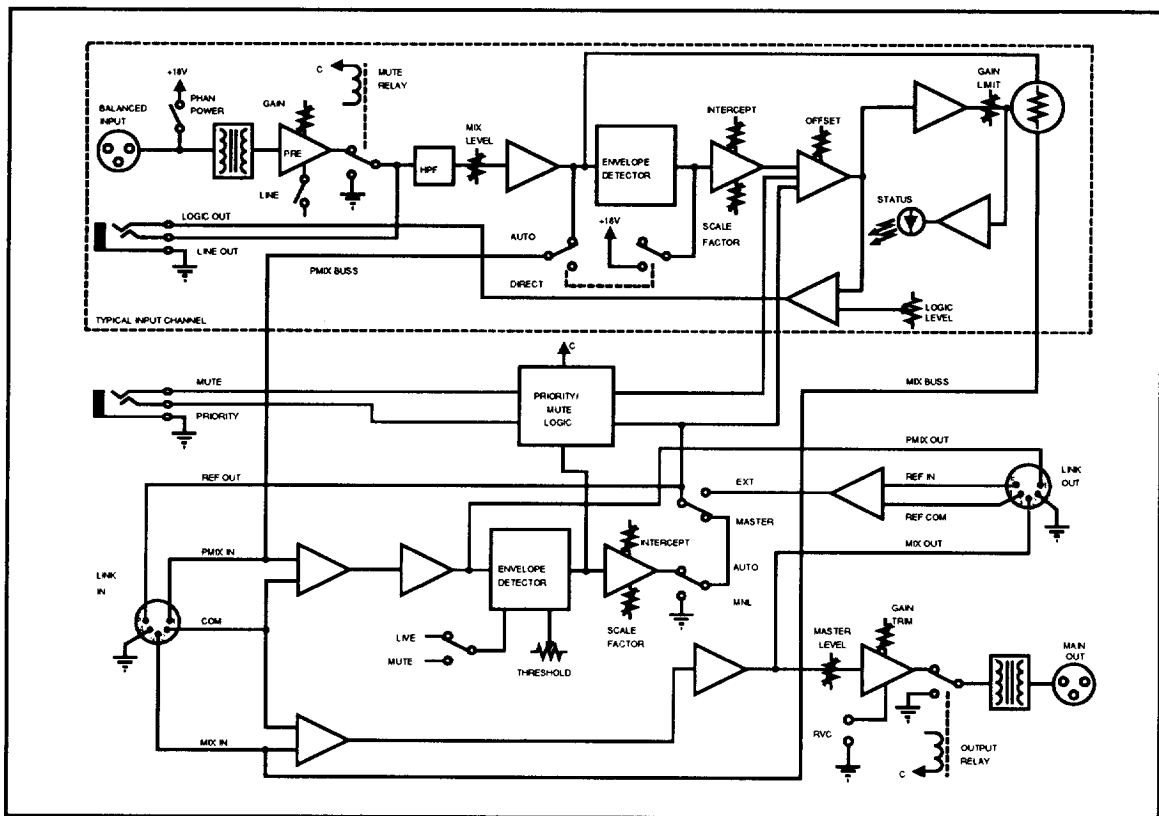

Figure 10: System Block Diagram



## **1684A Automatic Microphone Mixer**

### **SERVICE INSTRUCTIONS**

#### **\*\*\*CAUTION\*\*\***

No user serviceable parts inside. Hazardous voltage and currents may be encountered within the chassis. The service information contained within this document is for use only by ALTEC LANSING'S authorized warranty stations and qualified service personnel. To avoid electric shock, DO NOT perform any servicing other than that contained in the Operating Instructions unless you are qualified to do so. Refer all servicing to qualified service personnel.

**6 SERVICE INFORMATION**

**CAUTION:** No user serviceable parts inside. Hazardous voltages and currents may be encountered within the chassis. The service information contained within this document is for use only by **ALTEC LANSING** authorized warranty stations and qualified service personnel. To avoid electric shock **DO NOT** perform any servicing other than that contained in the Operating Instructions unless you are qualified to do so. Otherwise, refer all servicing to qualified service personnel.

**NOTE:** Modifications to **ALTEC LANSING** products are not recommended. Such modifications shall be at the sole expense of the person(s) or company responsible, and any damage resulting therefrom shall not be covered under warranty or otherwise.

**6.1 Parts Ordering**

To order replacement parts, look up the ordering number from the parts list and write/call:

ALTEC LANSING Parts Sales  
P.O. Box 26105  
Oklahoma City, OK 73126-0105 U.S.A.  
Phone: (405) 324-5311 FAX: (405) 324-8981

**6.2 Factory Service**

If factory service is required, ship the unit prepaid to:

ALTEC LANSING  
Customer Service/Repair  
10500 W. Reno  
Oklahoma City, OK 73128 U.S.A.

Enclose a note describing the problem in detail. Include other helpful information such as test conditions, where used, how used, etc.

**6.3 Technical Assistance**

For applications assistance/technical information, write or call:

ALTEC LANSING Technical Assistance  
P.O. Box 26105  
Oklahoma City, OK 73126-0105 U.S.A.  
Phone: (405) 324-5311 FAX: (405) 324-8981

**6.4 Electrical**

**6.4.1 115 Vac 50/60 Hz Operation**

The automatic microphone mixer is provided with its voltage select switch in the "115 V" position. The power supply design allows the mixer to be powered from 110 Vac to 130 Vac lines in this switch position.

**6.4.2 230 Vac 50/60 Hz Operation**

The automatic microphone mixer may be powered by line voltages from 220 Vac to 250 Vac, 50 or 60 Hz by switching the voltage select switch to the "230 V" position. It is located at the rear of the master pc board inside the chassis. Before operating the mixer with 230 Vac, the fuse must be changed. Refer to Table I for the proper fuse value.

AC Line Voltage	AC Line Fuse
110 - 130 V	300 mA
220 - 250 V	160 mA

**Table I:** Line Fuse Values

**WARNING:** Verify that the voltage select switch is in the desired position and the proper fuse value is in place for the intended ac line voltage **BEFORE** applying power to the mixer.

**6.5 Linking Into Existing Systems**

The **1684A** may be linked into existing systems with **1674C** and/or **1678C** models of **ALTEC LANSING** automatic microphone mixers. The **1684A** may not be linked with **1674B** or earlier models due to the buss level incompatibility.

To link the **1684A** with the "C" models, a few modifications must be made. Each input module must be modified as follows.

1. C7 and C10 must change to 0.1 µF, 100 V, film capacitors
2. R9 must change to 0 ohm jumper
3. R14 must change to 1 kohm, 1%, 0.25 W resistor

The master/power supply board must undergo the following changes.

1. C10 must change to 0.1 µf, 100 V, film capacitor
2. R17 must change to 100 ohm, 1%, 0.25 W resistor
3. R18 and R42 must change to 100 kohm, 1%, 0.25 W resistors

These changes assure that all control circuitry is compatible.

**6.6 Master/Power Supply Alignment Procedure**

This alignment procedure requires the following equipment:

Digital DC Voltmeter  
Signal Generator

1. Set the external switches and controls as follows. (Refer to Figure 11.)

MSTR/EXT on back panel: MSTR position  
AUTO/MNL on back panel: AUTO position  
Channel Volume controls: Fully CCW  
Master Volume control: Fully CCW  
Power switch: OFF position  
MIC/LINE: MIC position (OUT)

2. Set the internal switches as follows:

AUTO/DIRECT on each channel: AUTO  
HP Filter on each channel: OUT

Phantom power on each channel: OFF  
 MODE switch: LIVE  
 Voltage select switch: Appropriate position for ac line voltage

3. Power up unit.
4. Apply input signal of 1 kHz sine wave at 0 dBu to Link In connector (signal on pin 1, common on pin 2).
5. Monitor the DC voltage on the Link In connector (positive on pin 5 and common on pin 4). Verify the voltage is  $+10.00 \pm 0.1$  Vdc. If necessary adjust the INTERCEPT trimpot (R43). See Figure 11.
6. Reset signal generator output for 1 kHz at -40 dBu. Verify the DC voltage is  $+6.00 \pm 0.1$  Vdc. If adjustment is required proceed as follows:
  - a. Find difference between measured DC voltage and 6.00;  
 Example 1:  $6.12 \text{ Vdc} - 6.00 = 0.12$   
 Example 2:  $5.94 \text{ Vdc} - 6.00 = -0.06$ .
  - b. Multiply difference in Step a by 2.5;  
 Example 1:  $0.12 \times 2.5 = 0.30$  correction  
 Example 2:  $-0.60 \times 2.5 = -0.15$  correction.
  - c. Add 6.00 to the product in Step b;  
 Example 1:  $6.00 + 0.30 = 6.30$   
 Example 2:  $6.00 - 0.15 = 5.85$ .
  - d. Adjust SCALE trimpot (R47) for a Reference Output voltage of the resulting sum in Step c. See Figure 11.
  - e. Adjust INTERCEPT trimpot (R43) for a Reference Output voltage of  $+6.00$  Vdc.
7. Reset signal generator output for 1 kHz at 0 dBu and verify DC voltage is  $+10.00 \pm 0.1$  Vdc.
8. Remove the signal from the Link In connector and verify DC voltage is  $+4.00 \pm 0.1$  Vdc. Adjust THRESHOLD trimpot (R34), if necessary.

### 6.7 Input Module Alignment Procedure

Perform this procedure only after the Master/Power Supply alignment procedure has been completed.

This alignment procedure requires the following equipment:

Digital DC Voltmeter  
 Signal Generator  
 AC Voltmeter with dB scale  
 DC Voltage Supply (Variable 0-10 Vdc)

1. Connect AC voltmeter to monitor Line Out connector (positive on tip and common on sleeve).
2. Adjust signal generator output for 1 kHz at -50 dBu and set the GAIN control for 0 dBu on the

Line Out.

3. Connect AC voltmeter to monitor Link Out connector (positive on pin 1 and common on pin 2).
4. Adjust the Channel Volume level control for 0 dBu on the Link Out.
5. Monitor the DC voltage at TP1 on the input channel pcb (near the SCALE trimpot) with the D.V.M. Verify the voltage to be  $-10.00 \pm 0.1$  Vdc. Adjust the INTERCEPT trimpot (R18), if necessary.
6. Use the Channel Level control to lower the Link Out voltage to -40 dBu. Verify the voltage at TP1 to be  $-6.00 \pm 0.1$  Vdc. If adjustment is necessary proceed as follows:
  - a. Find difference between DC voltage and -6.00;  
 Example 1:  $-6.12 \text{ ref} - (-6.00) = -0.12$   
 Example 2:  $-5.94 \text{ ref} - (-6.00) = 0.06$ .
  - b. Multiply difference in Step a by 2.5;  
 Example 1:  $-0.12 \times 2.5 = -0.30$  correction  
 Example 2:  $0.60 \times 2.5 = 0.15$  correction.
  - c. Add -6.00 to the product in Step b;  
 Example 1:  $-6.00 - 0.30 = -6.30$   
 Example 2:  $-6.00 + 0.15 = -5.85$ .
  - d. Adjust SCALE trimpot (R20) for a TP1 voltage of the resulting sum in Step c.
  - e. Adjust INTERCEPT trimpot (R18) for a TP1 voltage of -6.00 Vdc.
7. Use the Channel Volume control to increase the Link Out voltage to 0 dBu and verify the TP1 voltage is  $-10.00 \pm 0.1$  Vdc.
8. Move the input signal connector to the next channel and repeat Steps 1 through 7.
9. Connect signal generator to Channel 1 input. Continue monitoring Link Out (positive on pin 1 and common on pin 2). Set the Channel Volume level control for an AC voltmeter reading of  $+10.0$  dBu (about 2 o'clock position). Set the AUTO/DIRECT switch on the input module to DIRECT.
10. Connect the AC voltmeter to monitor Link Out (positive on pin 3 and common on pin 2). Adjust the GAIN LIMIT trimpot (R31) on the input module for a Link Out voltage of  $+10.5$  dBu.
11. Set the AUTO/DIRECT switch to AUTO and adjust the OFFSET trimpot (R24) for a Link Out voltage of  $+10.00$  dBu.
12. Move the input signal connector to the next channel and repeat Steps 9 through 10.
13. With the signal generator output still 1 kHz at -50 dBu, reconnect it to Channel 1 input and verify all Channel Volume controls are still at about the 2 o'clock position.



*Operating and Service Instructions for the Altec Lansing 1684A Automatic Microphone Mixer*

14. Set the MODE switch (S1) on the Master pcb assembly to MUTE.
15. Adjust the THRESHOLD trimpot (R34) on Master pcb assembly to obtain a level of +7 dBu on pin 3 of the Link Out connector.
16. Monitoring the Logic Output with the D.V.M. (Line Out jack, ring to sleeve), adjust the LOGIC LEVEL trimpot (R25) to the point where the Logic Output voltage just drops to between 0.0 and +1.0 Vdc.
17. Set the MODE switch to LIVE and verify the Logic Output voltage is between +4.0 and +5.0 Vdc.
18. Move the input signal connector to the next channel and repeat Steps 14 through 17.
19. Verify the MODE switch is in LIVE position. Set all Channel Volume level controls fully CCW.
20. Adjust the THRESHOLD trimpot for a Reference Output voltage (pin 5 of Link In connector) of  $+4.00 \pm 0.10$  Vdc.

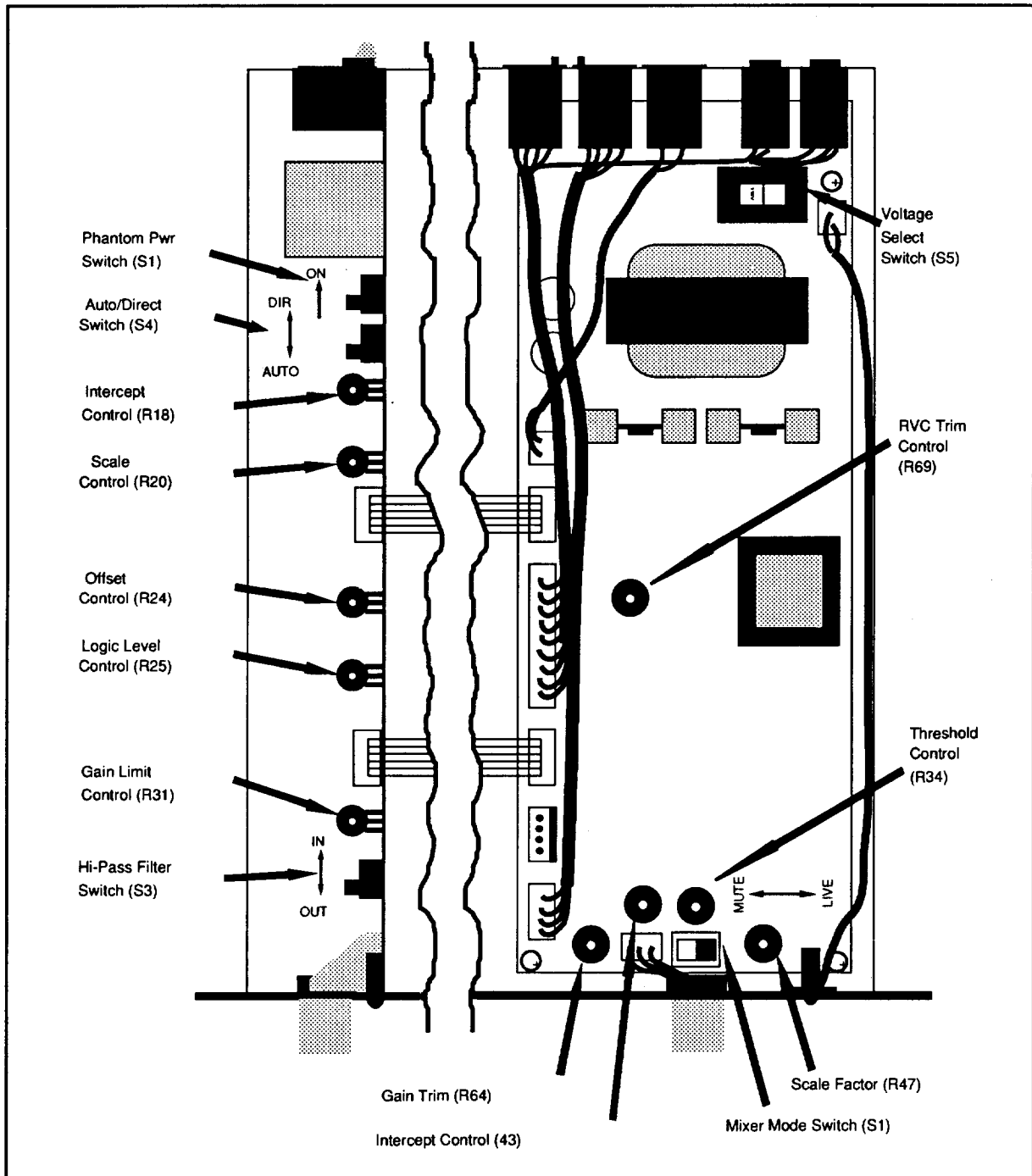

**Figure 11:** Location of components for alignment procedures.

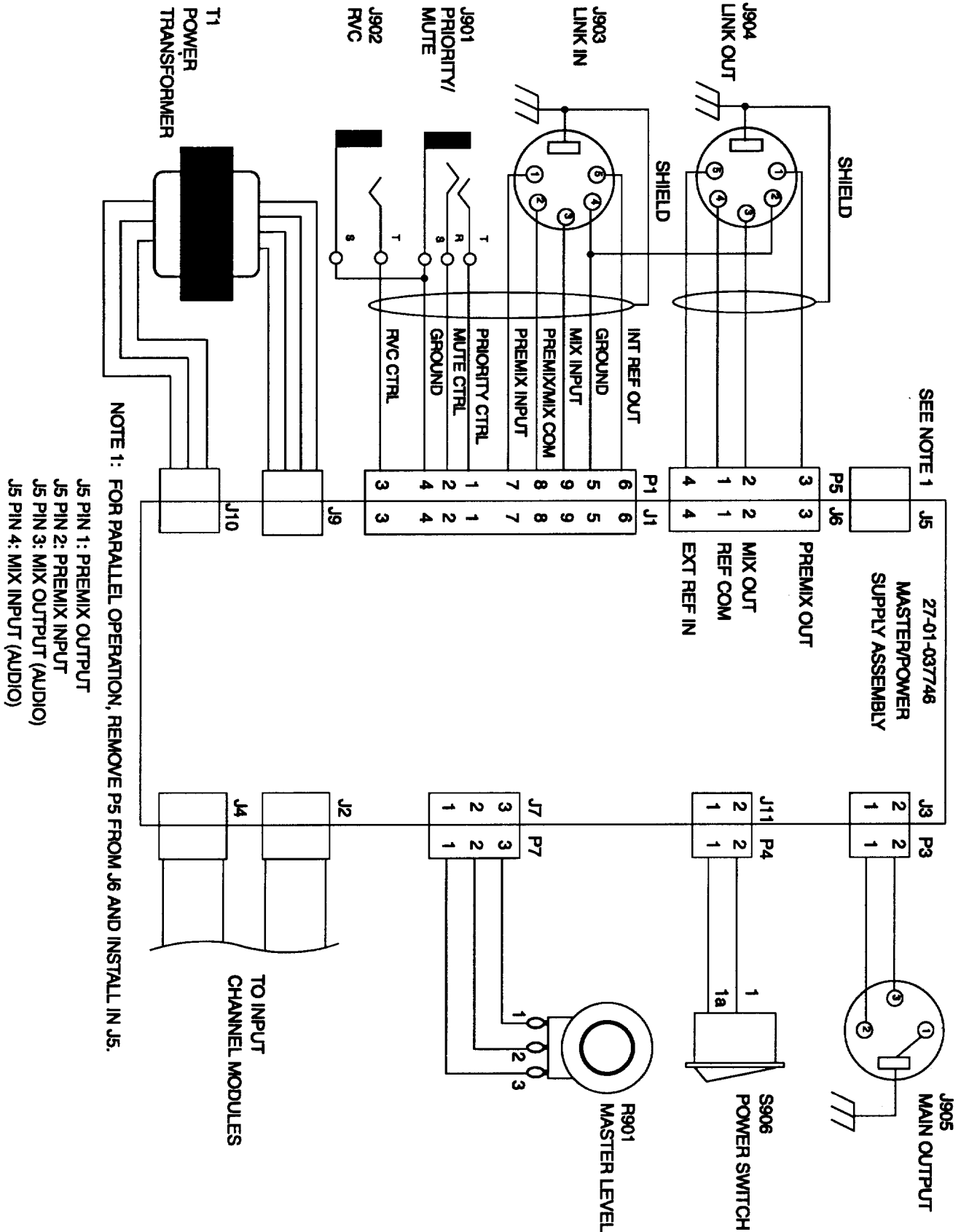

Figure 12: 1684A Assembly Drawing

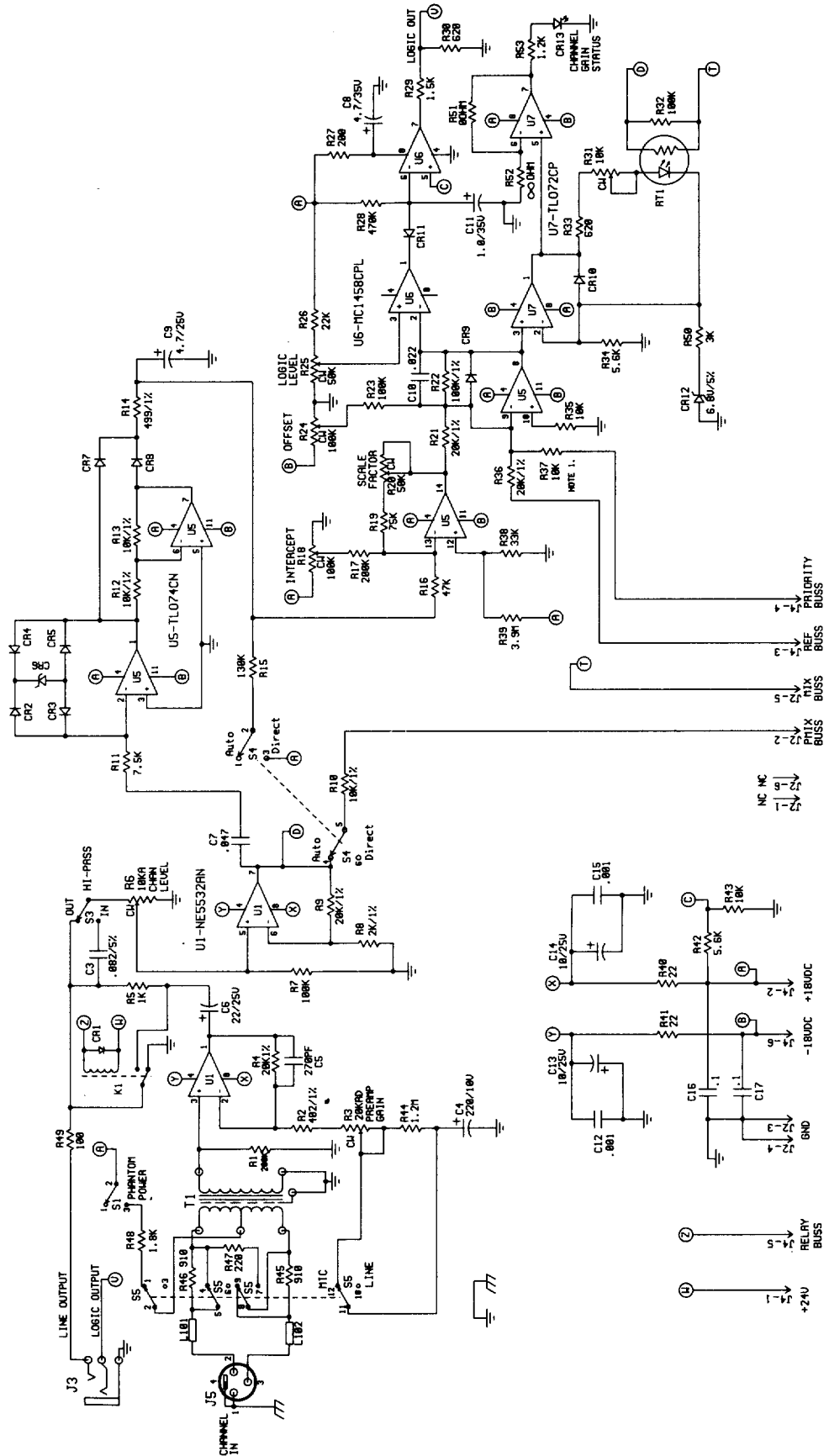

Figure 13: Input Module Schematic (11D886)

3. CAPACITORS ARE IN MICROFARADS UNLESS NOTED.
2. ALL RESISTORS ARE 1/4WATT 5% UNLESS NOTED.
1. R37 IS TO BE INSTALLED ON THE PRIORITY CHANNEL ONLY.

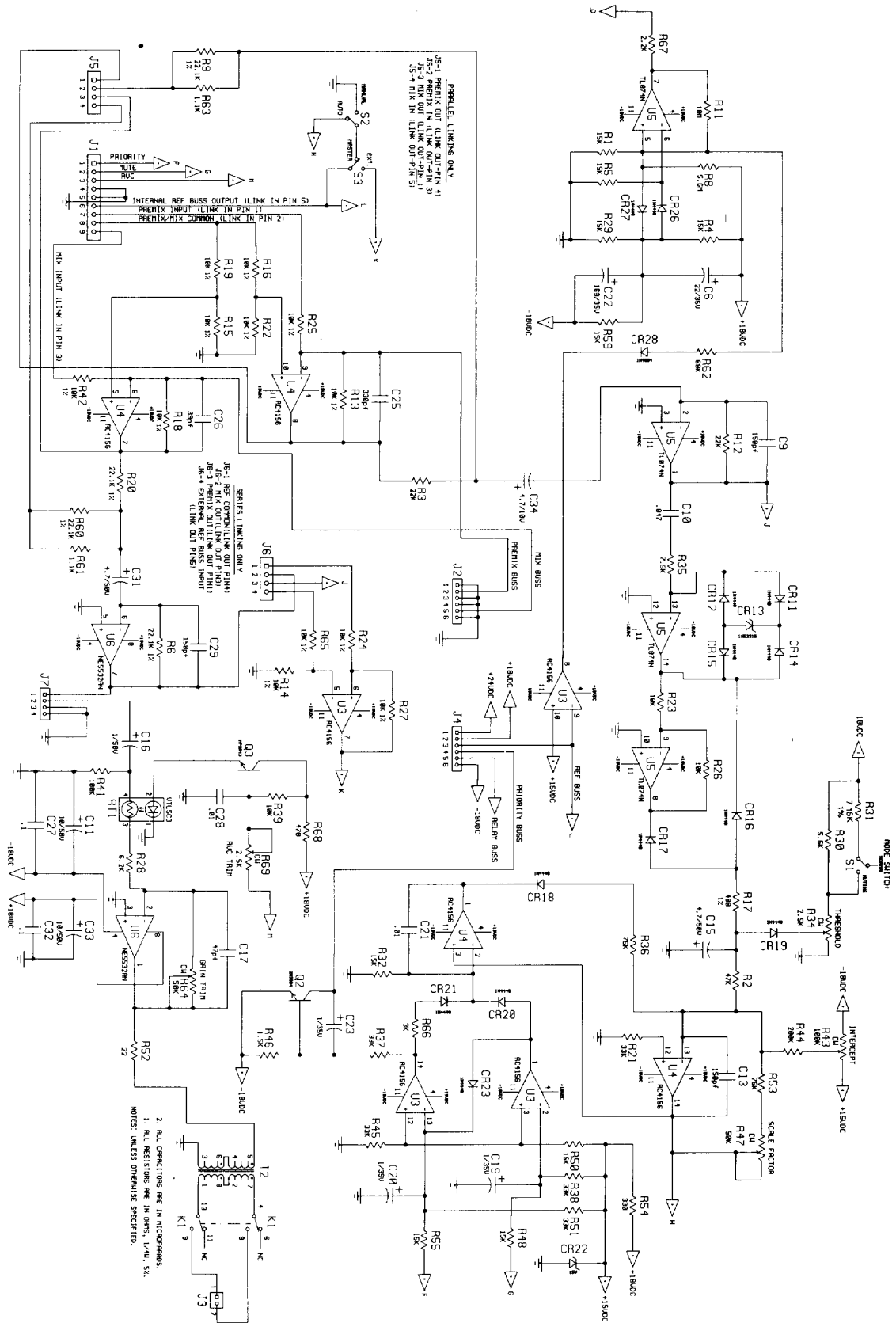

Figure 14: Master/Power Supply Board Schematic (11D840, Sheet 1)

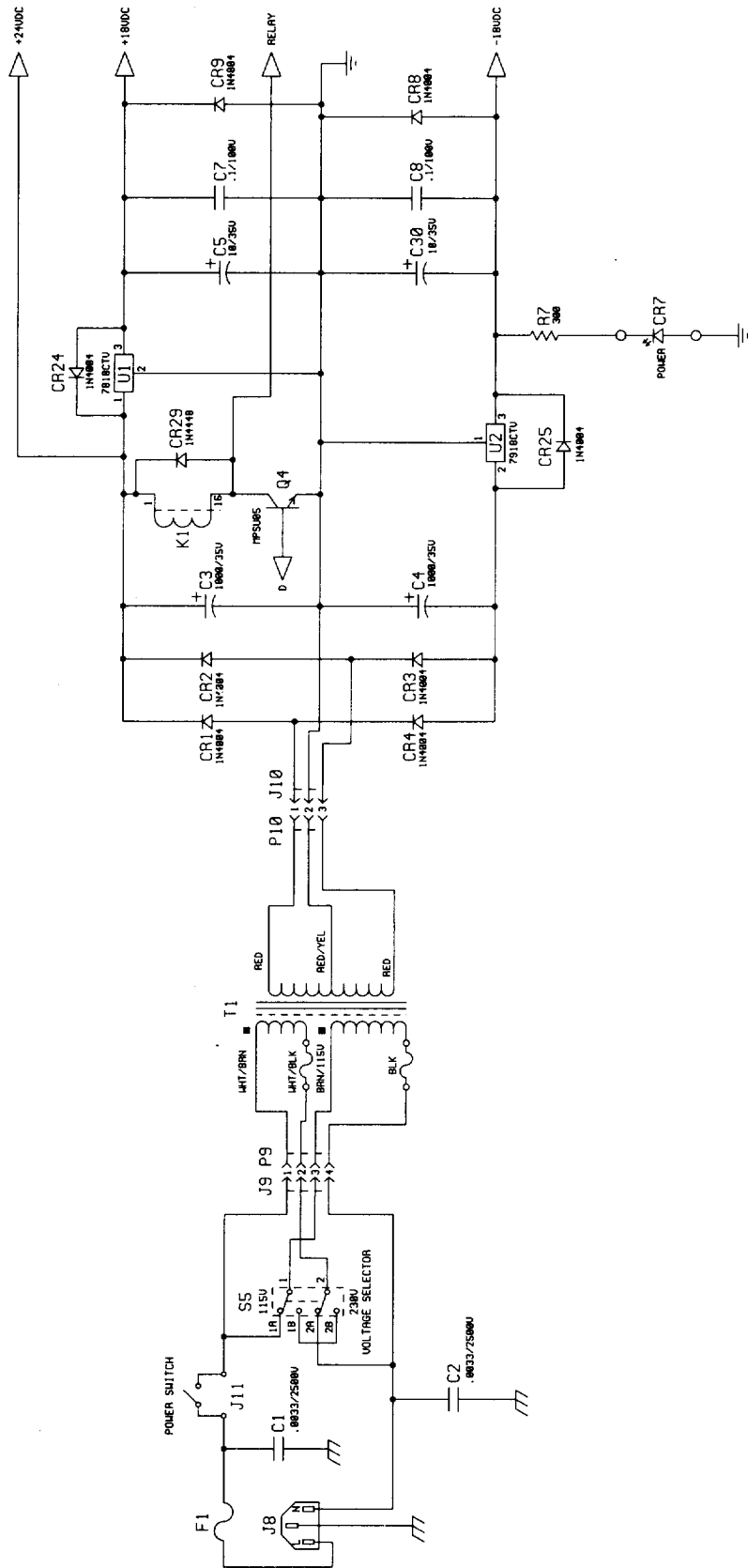
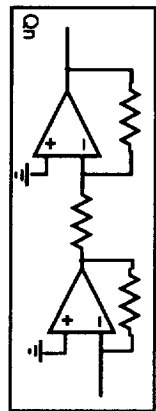

Figure 15: Master/Power Supply Board Schematic (11D840, Sheet 2)

If the interface is a considerable distance from the mixers, it is recommended that On be inserted. If this is done, remove resistors R61 and R63 from Master/Power Supply board.



All resistors are 22 k  $\Omega$   
For parallel operation, transfer P5 from J6 to J5 on Master/Power board.

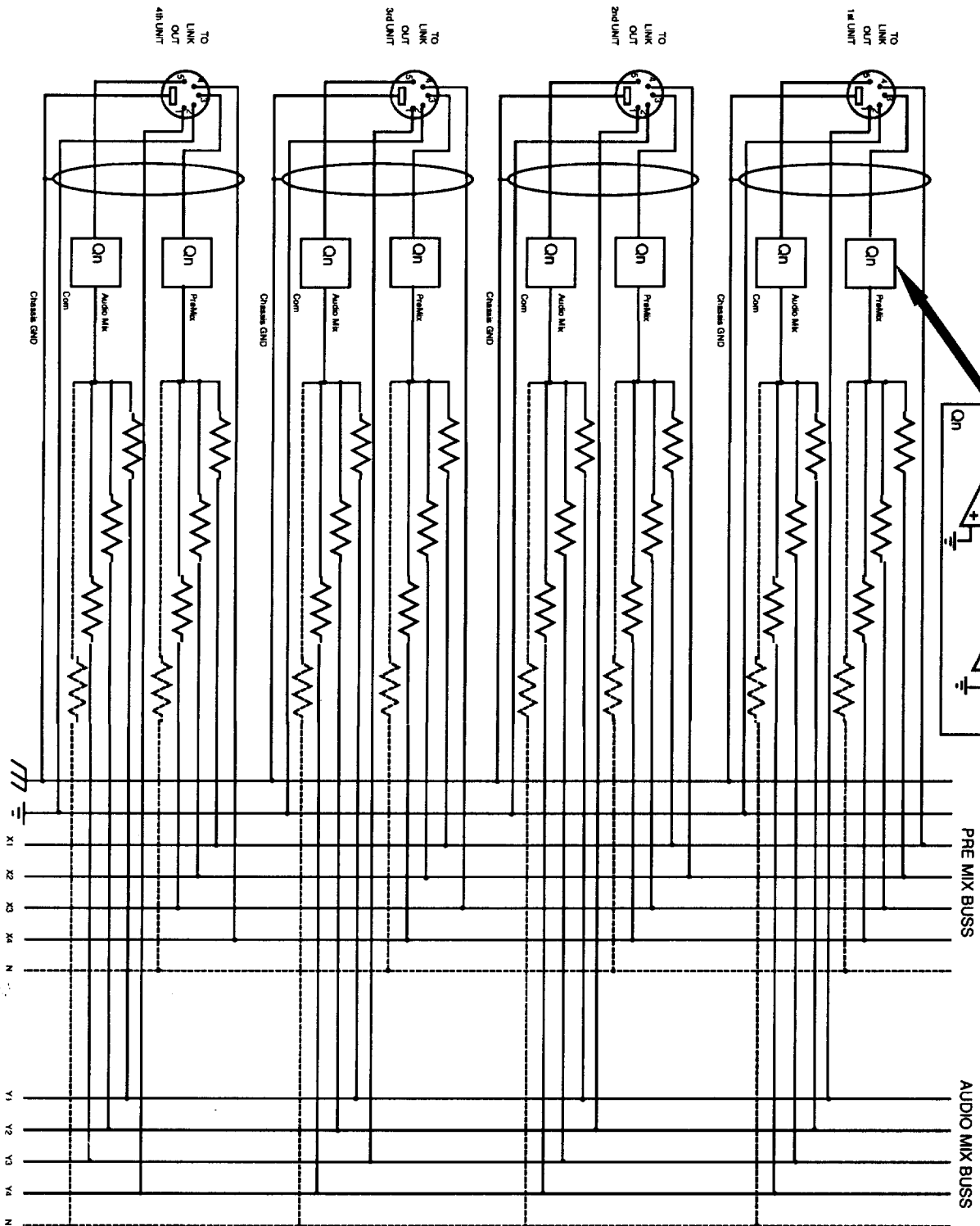

Figure 16: Parallel Linking Interface

## Component Parts List

### Main Assembly

Reference Designator	Ordering Number	Name and Description
N/A	10-01-037799	Wire Prep 1684A
N/A	14-02-038091	Blank panel
N/A	14-02-038106	Maestro cover, plastic
N/A	24-04-124846	Knob, 18 tooth knurled
N/A	27-01-037746	Master/Power Supply Assembly
N/A	27-01-037804	Input Module Assembly
N/A	28-02-110374	Nut, push-on clip
N/A	47-06-038075	Resistor, 10 kohm, 0.25 watt, 5%
N/A	51-04-038138	Fuse, 0.16 A/250 V slo-blo, 5 x 20 mm, export
N/A	51-07-125175	Cap, fuse 5 x 20 mm, export
J901	21-01-107505	Connector, ¼-inch phone jack, TRS, panel mount
J902	21-01-100494	Connector, ¼-inch phone jack, TS, panel mount
J903	21-02-122140	Connector, XLR, 5-pin, female, panel mount
J904	21-02-121278	Connector, XLR, 5-pin, male, panel mount
J905	21-02-122141	Connector, XLR, 3-pin, male, panel mount
R901	47-01-102102	Potentiometer, 10 kohm, 25 mm, A taper
S906	51-02-026775	Switch, rocker, SPST
T1	56-08-038817	Power transformer

### Input Module Assembly (27-01-037804)

Reference Designator	Ordering Number	Name and Description
N/A	14-17-037802	Input/Output Plate
N/A	24-04-028890	Knob, push button, light gray
C3	15-06-028024	Capacitor, 0.082 µF, 50V, 10%, film
C4	15-01-102611	Capacitor, 220 µF, 16 V, radial, electrolytic
C5	15-02-100032	Capacitor, 270 pF, 1000V, ceramic disk
C6	15-01-028154	Capacitor, 22 µF, 16 V, radial, electrolytic
C7	15-06-027367	Capacitor, 0.047 µF, 50V, 10%, film
C8,C9	15-01-028703	Capacitor, 4.7 µF, 63 V, radial, electrolytic
C10	15-06-028020	Capacitor, 0.022 µF, 50V, 10%, film
C11	15-01-028850	Capacitor, 1 µF, 35 V, radial, electrolytic
C12,C15	15-06-026823	Capacitor, 0.001 µF, 50V, 10%, film
C13,C14	15-01-028691	Capacitor, 10 µF, 50 V, radial, electrolytic
C16,C17	15-02-124437	Capacitor, 0.1 µF, 50V, ceramic disk
CR1,CR2,CR3,CR4,CR5,CR7,CR8, CR9,CR10,CR11	48-01-122601	Diode, signal, 1N4448
CR6	48-01-122988	Diode, zener, 5.1 V
CR12	48-01-122128	Diode, zener, 6.8 V
CR13	39-01-122876	LED, red, round, 2 V
J2,J4	21-01-037782	Connector, SIP header, 6 pin, 0.100" center
J3	21-01-028713	Connector, ¼-inch phone jack, TRS, pcb mount
J5	21-01-037785	Connector, XLR, 3-pin, female, pcb mount

Input Module Assembly (27-01-037804) cont.

Reference Designator	Ordering Number	Name and Description
J101,J103,J104,J107,J108,J110,J111, J112,J113,J114,J115,J116,J117, J121,J125,J126,J127,J129 J118,J119,J120,J122,J124,J128	21-01-110310	Jumper
K1	21-01-037783	Jumper, 1.0 inch
L101,L102	45-01-037784	Relay, SPDT, 24 Vdc
R1,R17	56-01-028815	Ferrite bead
R2	47-01-112203	Resistor, 200 kohm, 0.25 watt, 5%
R3	47-03-038092	Resistor, 402 ohm, 0.25 watt, 1%
R4,R9,R21,R36	47-06-037787	Potentiometer, 20 kohm, C taper, trim
R5	47-03-109434	Resistor, 20.0 kohm, 0.25 watt, 1%
R6	47-01-102078	Resistor, 1 kohm, 0.25 watt, 5%
R7,R23,R32	47-06-037791	Potentiometer, 10 kohm, 25 mm, w/ bracket
R8	47-01-102127	Resistor, 100 kohm, 0.25 watt, 5%
R10,R12,R13	47-03-119012	Resistor, 2.00 kohm, 0.25 watt, 1%
R11	47-03-109437	Resistor, 10.0 kohm, 0.25 watt, 1%
R14	47-01-102099	Resistor, 7.5 kohm, 0.25 watt, 5%
R15	47-03-037786	Resistor, 499 ohm, 0.25 watt, 1%
R16	47-01-102130	Resistor, 130 kohm, 0.25 watt, 5%
R18,R24	47-01-102119	Resistor, 47 kohm, 0.25 watt, 5%
R19	47-06-037790	Potentiometer, 100 kohm, trim
R20,R25	47-01-102124	Resistor, 75 kohm, 0.25 watt, 5%
R22	47-06-037788	Potentiometer, 50 kohm, trim
R26	47-03-119305	Resistor, 100 kohm, 0.25 watt, 1%
R27	47-01-102110	Resistor, 22 kohm, 0.25 watt, 5%
R28	47-01-102061	Resistor, 200 ohm, 0.25 watt, 5%
R29	47-01-109204	Resistor, 470 kohm, 0.25 watt, 5%
R30,R33	47-01-102082	Resistor, 1.5 kohm, 0.25 watt, 5%
R31	47-01-102073	Resistor, 620 ohm, 0.25 watt, 5%
R34,R42	47-06-037789	Potentiometer, 10 kohm, trim
R35,R43	47-01-102096	Resistor, 5.6 kohm, 0.25 watt, 5%
R38	47-01-102102	Resistor, 10 kohm, 0.25 watt, 5%
R39	47-01-102114	Resistor, 33 kohm, 0.25 watt, 5%
R40,R41	47-01-108931	Resistor, 3.9 Mohm, 0.25 watt, 5%
R44	47-01-102038	Resistor, 22 ohm, 0.25 watt, 5%
R45,R46	47-01-108933	Resistor, 1.2 Mohm, 0.25 watt, 5%
R47	47-01-102077	Resistor, 910 ohm, 0.25 watt, 5%
R48	47-01-102062	Resistor, 220 ohm, 0.25 watt, 5%
R49	47-01-102084	Resistor, 1.8 kohm, 0.25 watt, 5%
R50	47-01-102054	Resistor, 100 ohm, 0.25 watt, 5%
R51	47-01-102089	Resistor, 3 kohm, 0.25 watt, 5%
R53	21-01-110310	Jumper
RT1	47-01-102080	Resistor, 1.2 kohm, 0.25 watt, 5%
S1,S3	37-02-121322	Opto-coupler, LDR
S4	51-02-124565	Switch, slide, SPDT
S5	51-02-124458	Switch, slide, DPDT
T1	51-02-028058	Switch, push button, 4PDT
U1	56-04-015733	Transformer, input, audio
U5	17-01-122832	IC, dual op-amp, 5532A
U6	17-01-124461	IC, quad op-amp, TL074
U7	17-01-119310	IC, dual op-amp, MC1458
	17-01-124688	IC, dual op-amp, TL072



Master/Power Supply Assembly (27-01-037746)

Reference Designator	Ordering Number	Name and Description
C1,C2	15-02-122768	Capacitor, 0.0033 $\mu$ F, 125 VA, ceramic disk
C3,C4	15-01-122764	Capacitor, 1000 $\mu$ F, 35 V, radial, electrolytic
C5,C30	15-01-037019	Capacitor, 10 $\mu$ F, 35 V, radial, electrolytic
C6	15-01-037020	Capacitor, 22 $\mu$ F, 50 V, radial, electrolytic
C7,C8	15-02-100109	Capacitor, 0.1 $\mu$ F, 100 V, ceramic disk
C9,C13,C29	15-02-100027	Capacitor, 150 pF, 1000 V, ceramic disk
C10	15-06-028382	Capacitor, 0.047 $\mu$ F, 10%, 100 V, film
C11,C33	15-01-028691	Capacitor, 10 $\mu$ F, 50 V, radial, electrolytic
C15,C31,C34	15-01-124506	Capacitor, 4.7 $\mu$ F, 50 V, radial, electrolytic
C16	15-01-124507	Capacitor, 1 $\mu$ F, 50 V, radial, electrolytic
C17	15-02-107455	Capacitor, 47 pF, 100 V, ceramic disk
C19,C20,C23	15-01-028850	Capacitor, 1 $\mu$ F, 50 V, radial, electrolytic
C21,C28	15-06-124588	Capacitor, 0.047 $\mu$ F, 10%, 100 V, film
C22	15-01-027316	Capacitor, 1 $\mu$ F, 50 V, radial, electrolytic
C25	15-02-107532	Capacitor, 0.1 $\mu$ F, 100V, ceramic disk
C26	15-02-120211	Capacitor, 150 pF, 1000V, ceramic disk
C27,C32	15-02-028693	Capacitor, 0.1 $\mu$ F, 100V, ceramic disk
CR1,CR2,CR3,CR4,CR8,CR9,CR24, CR25,CR28	48-02-042787	Diode, 400 V, 1N4004
CR7	39-03-122943	LED, red w/ black body, 12 inch leads
CR11,CR12,CR14,CR15,CR16,CR17, CR18, CR19, CR20, CR21, CR23 CR26,CR27,CR29	48-01-122601	Diode, signal, 1N4448
CR13	48-01-122988	Diode, zener, 5.1 V
CR22	48-01-108576	Diode, zener, 15 V
F1	51-04-037959	Fuse, 0.3 A/250 V, 3AG
J1	21-04-124401	Connector, SIP header, 9 pin, 0.156" center
J2,J4	21-01-125103	Connector, SIP header, 6 pin, 0.100" center
J3,J11	21-04-124415	Connector, SIP header, 2 pin, 0.156" center
J5,J6,J9	21-04-124416	Connector, SIP header, 4 pin, 0.156" center
J7	21-01-036123	Connector, SIP header, 4 pin, 0.100" center
J8	21-02-124466	Connector, IEC, AC power
J10	21-01-122987	Connector, SIP header, 3 pin, 0.156" center
K1	45-01-037749	Relay, DPDT, 24 V
Q2	48-03-121306	Transistor, NPN, 2N3904
Q3	48-03-120233	Transistor, NPN, MPSA43
Q4	48-03-028711	Transistor, NPN, MPSU05
R1,R4,R5,R29,R32,R48,R50,R55,R59	47-01-102106	Resistor, 15 kohms , 0.25 watt, 5%
R2	47-01-102119	Resistor, 47 kohms , 0.25 watt, 5%
R3,R12	47-01-102110	Resistor, 22 kohms , 0.25 watt, 5%
R6,R9,R20,R60	47-03-122953	Resistor, 22.1 kohms , 0.25 watt, 1%
R7	47-01-102065	Resistor, 300 ohms, 0.25 watt, 5%
R8	47-01-113206	Resistor, 5.6 Mohms, 0.25 watt, 5%
R11	47-01-107373	Resistor, 10 Mohms, 0.25 watt, 5%

Master/Power Supply Assembly (27-01-037746) cont.

Reference Designator	Ordering Number	Name and Description
R13,R14,R15,R16,R18,R19,R22,R24, R25,R27,R42,R65	47-03-109437	Resistor, 10.0 kohms, 0.25 watt, 1%
R17	47-03-037786	Resistor, 499 ohms, 0.25 watt, 1%
R21,R37,R38,R45,R51	47-01-102114	Resistor, 33 kohms, 0.25 watt, 5%
R23,R26,R39	47-01-102102	Resistor, 10 kohms, 0.25 watt, 5%
R28	47-01-102097	Resistor, 6.2 kohms, 0.25 watt, 5%
R30	47-03-124652	Resistor, 5.62 kohms, 0.25 watt, 1%
R31	47-03-124653	Resistor, 7.15 kohms, 0.25 watt, 1%
R34,R69	47-06-122138	Potentiometer, 2.5 kohms, trim
R35	47-01-102099	Resistor, 7.5 kohms, 0.25 watt, 5%
R36,R53	47-01-102124	Resistor, 75 kohms, 0.25 watt, 5%
R41	47-01-102127	Resistor, 100 kohms, 0.25 watt, 5%
R43	47-06-122136	Potentiometer, 100 kohms, trim
R44	47-01-112203	Resistor, 200 kohms, 0.25 watt, 5%
R46	47-01-102082	Resistor, 1.5 kohms, 0.25 watt, 5%
R47,R64	47-06-122135	Potentiometer, 50 kohms, trim
R52	47-01-102038	Resistor, 22 ohms, 0.25 watt, 5%
R54	47-01-102066	Resistor, 330 ohms, 0.25 watt, 5%
R61,R63	47-01-102079	Resistor, 1.1 kohms, 0.25 watt, 5%
R62	47-01-102123	Resistor, 68 kohms, 0.25 watt, 5%
R66	47-01-102089	Resistor, 3 kohms, 0.25 watt, 5%
R67	47-01-102086	Resistor, 2.2 kohms, 0.25 watt, 5%
R68	47-01-102070	Resistor, 470 ohms, 0.25 watt, 5%
RT1	37-02-121322	Opto-coupler, LDR
S1	51-02-124565	Switch, slide, SPDT
S2,S3	51-02-037747	Switch, toggle
S5	51-02-037748	Switch, AC line select
T2	56-07-026392	Transformer, output, audio
U1	17-01-118679	IC, +18 V regulator, 7818
U2	17-01-125076	IC, -18 V regulator, 7918
U3,U4	17-01-121819	IC, quad op-amp, RC4156
U5	17-01-122131	IC, quad op-amp, TL084
U6	17-01-122832	IC, dual op-amp, 5532A